



## ENGINEER'S REPORT

(Drainage Act, RSO 1990, c. D.17)

**PROJECT** | **Bridge Over the 11th Concession Road Drain  
West of Ruscom River**  
For Donald & Shannon Ames (620-02100)  
Part of Lot 19, Concession 10  
(Geographic Township of Gosfield North)  
Town of Kingsville, County of Essex  
**Project No. D25-016**

September 30, 2025

**N.J. Peralta Engineering Ltd.**

45 Division Street North  
Kingsville, ON N9Y 1E1  
519-733-6587  
peraltaengineering.com

This page has been intentionally left blank

## PREAMBLE

### **MUNICIPAL DRAINS AND THE DRAINAGE ACT**

The "Drainage Act" is one of the oldest pieces of legislation in Ontario, passed in 1859. It provides a democratic procedure for the construction, improvement and maintenance of drainage works. A procedure whereby the Municipality may assist in providing a legal drainage outlet for surface and subsurface waters not attainable under common law. Accordingly, provides much-needed assistance to facilitate the problems of obtaining a legal drainage outlet, engineering and cost distribution.

The Drainage Act provides a legal procedure by which an "area requiring drainage" may receive an outlet drain constructed to dispose of excess stormwater runoff to a sufficient outlet. This drainage infrastructure is otherwise known as a "Municipal Drain". Municipal Drains are identified by Municipal By-Law that adopts an Engineer's Report. The drainage engineer has the obligation to prepare an unbiased Engineer's Report based on information presented in written form, orally, and from visual inspection; in accordance with currently accepted design criteria. These reports form the legal basis for construction and management of the Municipal Drain. As such, an Engineer's Report shall contain specific details such as plans, profiles, and specifications that define the location, size and depth of the drainage infrastructure, together with establishing how costs are shared amongst all stakeholders.

Through the democratic procedure, the Engineer's Report is presented to all Stakeholders in front of Municipal Council (or a Drainage Board appointed by Council) for consideration. The Drainage Act provides an appeal process to address various aspects of Municipal Drains. These appeal bodies are the Court of Revision, the Ontario Drainage Tribunal and the Drainage Referee.

For additional information, Fact Sheets, and reference materials regarding the Drainage Act and Municipal Drains, please visit: <https://www.ontario.ca/page/agricultural-drainage>

This page has been intentionally left blank

## TABLE OF CONTENTS

I.	Introduction.....	2
II.	Background and Drain History .....	3
III.	Preliminary Investigations and On-Site Meeting .....	3
IV.	Field Survey .....	5
V.	Findings and Recommendations .....	5
VI.	Allowances and Compensation .....	7
VII.	Estimate of Cost.....	7
VIII.	Drawings and Specifications.....	8
IX.	Construction Schedule of Assessment Rationale .....	8
X.	Future Maintenance.....	9
	Construction Schedule of Assessment .....	11
	Standard Specifications – General .....	SSG-1 to SSG-8
	Standard Specifications – New Access Bridge Installation .....	SSB-1 to SSB-16
	Special Provisions .....	SP-1 to SP-6

## APPENDICES

### **Appendix “A” – Environmental Considerations**

Appendix A-1 – ERCA Correspondence

Appendix A-2 – DFO Best Management Practices

### **Appendix “B” – Plan of Survey (12R-29965)**

**Design Drawings - Sheets 1 to 1**

This page has been intentionally left blank

**PROJECT** **Bridge Over the 11th Concession Road Drain  
West of Ruscom River**  
For Donald & Shannon Ames (620-02100)  
Part of Lot 19, Concession 10  
(Geographic Township of Gosfield North)  
Town of Kingsville, County of Essex  
**Project No. D25-016**

September 30, 2025

**Mayor and Municipal Council**

Corporation of the Town of Kingsville  
2021 Division Road North  
Kingsville, ON N9Y 2Y9

**I. INTRODUCTION**

In accordance with the instructions received by letter of February 20, 2025, from the Town of Kingsville's Drainage Department, we have completed the necessary survey, examinations, investigations, etc. and have prepared the following report to provide for the installation of a new access bridge within the 11th Concession Road Drain West of Ruscom River. The proposed access bridge is intended to serve as the primary access for the severed agricultural land currently owned by Donald & Shannon Ames (620-02100), in Part of Lot 19, Concession 10, in the Geographic Township of Gosfield North. These investigations were initiated by a resolution passed by Council for our firm to undertake the preparation of an Engineer's Report for the works within this Municipal Drain and in accordance with provisions of the Drainage Act. The 11th Concession Road Drain West of Ruscom River is generally an open drain with a number of access bridges, which were constructed under the auspices of the Drainage Act. A plan showing the alignment of the 11th Concession Road Drain West of Ruscom River, the general location of the proposed access bridge within the Municipal Drain, and details for the general improvements under this project are included herein as part of this report.

Our appointment and the works relative to the 11th Concession Road Drain West of Ruscom River proposed under this report, are being conducted in accordance with Section 78 of the "Drainage Act, RSO 1990, Chapter D.17, as amended in 2021". We have performed all of the necessary survey, investigations, etc., for the proposed access bridge, as well as the 11th Concession Road Drain West of Ruscom River, and we report thereon as follows.

---

## **II. BACKGROUND AND DRAIN HISTORY**

### **Background**

The Owners of the subject agricultural lands, Donald & Shannon Ames (620-02100), are currently working through final approvals to sever the existing homestead from the agricultural land. The subject farm parcel has an existing access bridge over the 11th Concession Road Drain West of Ruscom River that currently facilitates the residential portion of the property. Based on the details outlined within the Town of Kingsville's Consent Application, a new farm access bridge must be provided to facilitate the retained farmland. Accordingly, a formal request for improvements was submitted by the property owners to the Town of Kingsville to appoint an Engineer through the provisions of the Drainage Act.

### **Drainage History**

From our review of the Town of Kingsville's drainage records, we have determined that the 11th Concession Road Drain West of Ruscom River is an open Municipal Drain that has been repaired and improved on a number of previous occasions through the auspicious of the Drainage Act. The 11th Concession Road Drain West of Ruscom River is located along the south side of Road 11 and commences between Lots 16 and 17, Concession 10 and continues easterly to its outlet into the Ruscom River.

From our review, we have found several Engineer's Reports prepared through the provisions of the Drainage Act for the 11th Concession Road Drain West of Ruscom River. However, we have outlined the following relevant Engineer's Report that we utilized as a reference for carrying out this project:

- a) **June 18, 1976**, Reconsidered Engineer's Report for the "11th Concession Road Drain West of Ruscomb River", prepared by William J. Setterington, P.Eng., was carried out under Township of Gosfield North By-Law No. 516. The works conducted under this report generally provided for the excavation and improvement of the entire length of the drain, together with the installation of a new access bridge.

From our detailed research of the above-listed Engineer's Report, we have determined that the 1976 Report serves as the current governing By-Law for the 11th Concession Road Drain West of Ruscom River. We have utilized this report to establish the size parameters and grades for the drain, together with the necessary details to be utilized in establishing the proposed access culvert installation.

## **III. PRELIMINARY INVESTIGATIONS AND ON-SITE MEETING**

After reviewing all the available drainage information and documentation provided by the Drainage Superintendent, an On-Site Meeting was scheduled for May 14, 2025. The following people were in attendance at this meeting:

Name	Affiliation
Donald (Leigh) Ames	Landowner – 516 Road 11
Mark Fishleigh	County of Essex
Lu-Ann Marentette	Kingsville's Drainage Superintendent
Kiara Kirkland	N.J. Peralta Engineering Ltd.
Tony Peralta, P.Eng.	N.J. Peralta Engineering Ltd.

At the onset of this meeting, Lu-Ann Marentette made introductions and generally advised that a written notice had been submitted by Donald & Shannon Ames (620-02100) for the installation of a new access bridge structure.

Tony Peralta provided a brief history of the 11th Concession Road Drain West of Ruscom River relative to the subject property and outlined its status as a Municipal Drain, through the provisions of the Drainage Act. Tony further explained that a Municipal Drain is a communally accepted drain and that all landowners within the watershed are considered stakeholders. Tony outlined that the purpose of this "On-Site Meeting" is to provide a general introduction to the project while initiating dialogue with the affected stakeholders to establish and confirm the general scope of work for the project. Tony encouraged those in attendance to provide as much input as possible to ensure that all applicable details are included within the investigations.

Tony provided a general overview of the project details, process, and specifics of the new access bridge. The Owner advised that he had started the consent application process to sever the homestead from the agricultural land and that this access bridge was a condition for the consent application. Tony advised that since the consent application had been started, this bridge would not be eligible for the grant from OMAFA.

Mr. Ames advised that the new access should be located on the east side of the residential portion of the property, where stakes have been set to identify the preferred location. Tony identified that the minimum standard top width of the driveway is 6.10 metres (20.00 ft.). Furthermore, if the Owner requires a top width wider than the standard 6.10 metres (20.00 ft.), the additional cost for providing a top width wider than the standard shall be assessed 100% to the abutting Owner for both the initial construction and future maintenance. The Owner advised that his tenant farmer suggested that the new access bridge have a minimum top width of 7.62 metres (25.00 ft.) top width. However, after further review of the existing site parameters and the limited gravel shoulder width, Mr. Ames has indicated that a minimum access width of 9.10 metres (30.00 ft.), with sloped quarried limestone end treatments, would provide sufficient top width to accommodate modern farming equipment.

Tony reviewed the general process through the Drainage Act for the new bridge installation. The overall drainage report and future maintenance processes, general timelines, and grant eligibility were generally reviewed. We also discussed general timelines for construction. The Owner was also advised that it would be likely that the works in this drain were not to be undertaken between March 15 and July 15, unless otherwise permitted by DFO, ERCA, MNRF, and the MECP.

On this note, the On-Site Meeting came to a close.

#### **IV. FIELD SURVEY**

Following our On-Site Meeting, we arranged for our Survey Crew to attend the site to perform a topographic survey, including taking all necessary levels and details, to establish the design parameters for the installation of the new access bridge structure.

Benchmarks were looped from previous work carried out on the drain and were utilized in establishing a relative site Benchmark near the location of the new access bridge. We surveyed the drain for a considerable distance both upstream and downstream of the proposed access bridge site in order to establish a design grade profile for the installation of the new access bridge. We also took cross-sections of the 11th Concession Road Drain West of Ruscom River at the general location of the new access bridge site, as necessary, for us to complete our design calculations, estimates and specifications.

The Ministry of Environment, Conservation and Parks (MECP) currently regulates the Endangered Species Act, 2007. New regulation provisions under Ontario Regulation 242/08, Section 23.9, allow the Municipality to conduct repairs, maintenance, and improvements within existing Municipal Drains, under the Drainage Act, and these works are exempt from Sections 9 and 10 of the Endangered Species Act, so long as the rules in the regulation are followed. If eligible, the regulatory provision allows Municipalities to give notice to the Ministry by registering their drainage activities through an online registry system.

Prior to our appointment to this project, we understand that the Town of Kingsville provided the Essex Region Conservation Authority (ERCA) with a notice advising of the proposed drainage works, as required under Section 78(2) of the Drainage Act. Based on their comments, we engaged in further correspondence with the ERCA regarding specific requirements for the approval of the proposed bridge design.

For the purpose of establishing the watershed area, we investigated and reviewed all of the past Engineer's Reports on the 11th Concession Road Drain West of Ruscom River. Specifically, we utilized the governing report from 1976 to establish the watershed contributing to the overall drainage system. In addition, we utilized current LiDAR information to cross-check the watershed limits upstream of the new access bridge. All of the above investigations not only provided us with the correct watershed area affecting the size of the new access bridge but also provided us with accurate information to assist us with the preparation of our Construction Schedule of Assessment for this project.

#### **V. FINDINGS AND RECOMMENDATIONS**

Based on our topographic survey, detailed investigations, information derived from the On-Site Meeting and subsequent discussions and review with affected landowners, together with the review and correspondence with the ERCA and other environmental government agencies, we have proceeded to establish the required details to adequately address the specified improvements within the 11th Concession Road Drain West of Ruscom River. Our findings and recommendations are outlined in the following paragraphs.

### **ERCA, DFO, and MECP Considerations**

During the course of our investigations, this drainage project's details were reviewed with Ashley Gyori, of the ERCA, to deal with any ERCA concerns and comments related to this Municipal Drain. The 11th Concession Road Drain West of Ruscom River is located within the regulated area and is under the jurisdiction of the ERCA. Therefore, an ERCA Permit is required for the construction of the proposed access bridge structure. Further to the above, ERCA provided us with their comments and concerns through email correspondence, and said correspondence is included herein as **Appendix "A"**.

With respect to the Department of Fisheries and Oceans (DFO) concerns and comments, the proposed works within this Municipal Drain were "self-assessed" by the Engineer, through the DFO website and the utilization of the "Guidance for Maintaining and Repairing Municipal Drains in Ontario" to determine whether this project shall be reviewed by the DFO. The section of the 11th Concession Road Drain West of Ruscom River, where the access bridge will be installed, has been established as Class 'F' by the DFO. Based on the DFO Self-Assessment website and the guidance document, we have determined that the project activities would not require a DFO review for the works proposed under this project, so long as standard measures for fish habitat and migration are implemented. A copy of the DFO "Best Management Practices – Culvert Replacements in Municipal Drains" document is also included within **"Appendix A."**

The Ministry of Natural Resources and Forestry (MNR) transitioned the responsibilities of the Species at Risk Provincial Legislation to the Ministry of the Environment, Conservation and Parks (MECP). Section 23.9 of the Endangered Species Act, 2007 allows the Municipality to conduct eligible repair, maintenance, and improvement work under the Drainage Act that exempts these works from Sections 9 and 10 of this Act, so long as they follow the rules within Ontario Regulation 242/08.

In recognition of the impact that these species may experience as a result of the subject works, the Town of Kingsville has provided comprehensive mitigation measures as well as species identification guides for reference. These references shall be provided to the successful Tenderer and shall be available for viewing at the Municipal Office for those interested.

Through correspondence with the ERCA, the DFO, and our submission through the Endangered Species Act, we have addressed all of the ERCA, DFO, and MECP concerns and comments in our design and recommend that these drainage works be constructed in total compliance with all of the above.

### **Access Structure Details**

Further to our discussions and instructions established at the On-Site Meeting, and per the subsequent correspondence, we have reviewed the proposed access structure within the 11th Concession Road Drain West of Ruscom River, which pertains to the proposed residential severance from the existing agricultural lands. The residential severance has been identified as Part 1 of the Registered Plan 12R-29965. A copy of this Plan is included within this Report and is identified in **Appendix "B"**.

Prior to the completion of our Engineer's Report on this project, we had contacted the landowners, Donald & Shannon Ames (620-02100), to review the particulars of the new access bridge. Mr. Ames confirmed that he wished to proceed with a driveway top width of 9.10 metres (30.00 ft.) with sloped quarried limestone end treatments. Based on the confirmed top width and end treatment, we reviewed our preliminary design

and determined that the new access bridge would require approximately 18.00 metres (59.06 ft.) of 2200mm corrugated steel pipe. Mr. Ames further advised that he understands that all costs associated with the construction and incidentals of this new access bridge will be his responsibility, and he accepted our recommendations with respect to this access bridge installation. This report and the works proposed herein have been prepared on that basis.

Based on all the above, we recommend that a new access bridge be constructed in the 11th Concession Road Drain West of Ruscom River to serve as the primary access to the agricultural lands currently owned by Donald & Shannon Ames (620-02100) in Part of Lot 19, Concession 10, in accordance with this report, the attached specifications and the accompanying drawings. All works associated with this project shall be carried out in accordance with Section 78 of the "Drainage Act, RSO 1990, Chapter D.17, as amended 2021".

**VI. ALLOWANCES AND COMPENSATION**

All of the work carried out under this project is located alongside and within the south limit of Road 11. Furthermore, all areas disturbed by this work are specified for full restoration. Therefore, these works shall not require land to be taken, nor result in any loss of production of agricultural property or any indirect damages to the non-agricultural areas. Therefore, no allowances or compensation shall be provided under Sections 29 and 30 of the "Drainage Act, RSO 1990, Chapter D.17, as amended 2021".

**VII. ESTIMATE OF COST**

Our estimate of the total cost of this work, including all incidental expenses, is the sum of **SIXTY-SIX THOUSAND SEVEN HUNDRED AND FORTY DOLLARS (\$ 66,740.00)** made up as follows:

<b>CONSTRUCTION ITEMS</b>					
Item	Description	Est Qty	Unit	Unit Price	Total
1.	Provide all labour, equipment and materials to construct a new access bridge consisting of 18.00 metres (59.06 ft.) of 2200mm diameter, 2.0mm thick, Aluminized Steel Corrugated Hel-Cor Pipe with annular ends and 125mm x 25mm Corrugations, sloped quarried limestone on filter cloth end protection, granular bedding and backfill, granular approaches and transitions, excavation, compaction, topsoil, seeding and mulching, cleanup and restoration, complete.	1	Lump Sum	\$ 47,000.00	\$ 47,000.00
2.	Net HST for the above construction items (1.76%)				\$ 827.00
<b>TOTAL FOR CONSTRUCTION =</b>					<b>\$ 47,827.00</b>

INCIDENTALS		
Item	Description	Total
1.	Report, Estimates and Specifications	\$ 7,400.00
2.	Survey, Assistants, Expenses and Drawings	\$ 6,100.00
3.	Duplication Costs of Report and Drawings	\$ 700.00
4.	Estimated Cost of preparing Tender Documents for use by the Municipality for Letting of the Contract on an invitation basis	\$ 1,800.00
5.	Estimated Cost for Full-Time Inspection, Supervision and Project Management during Construction (approx. 1-day duration)	\$ 1,800.00
6.	Net HST on the above items (1.76%)	\$ 313.00
7.	Estimate Cost for ERCA Permit	\$ 800.00
<b>TOTAL FOR INCIDENTALS =</b>		<b>\$ 18,913.00</b>
<b>TOTAL FOR CONSTRUCTION</b> (brought forward) =		<b>\$ 47,827.00</b>
<b>TOTAL ESTIMATE =</b>		<b>\$ 66,740.00</b>

**VIII. DRAWINGS AND SPECIFICATIONS**

As part of this report, we have attached design drawings for the construction of this access bridge. The design drawings show the alignment of the 11th Concession Road Drain West of Ruscom River and the approximate location of the subject access bridge within this Municipal Drain. The drawings also illustrate the affected landowner and the details associated with the proposed new access bridge installation. The design drawings are attached to the back of this report and have been labelled herein as **Appendix "B"**.

Also attached, we have prepared Standard Specifications and Special Provisions which set out the required construction details for the proposed bridge installation, as set out under this Report.

**IX. CONSTRUCTION SCHEDULE OF ASSESSMENT RATIONALE**

**Construction Schedule of Assessment**

We would recommend that all of the costs associated with the construction of the new primary access bridge, as described above and detailed herein, be totally assessed against the lands currently owned by Donald & Shannon Ames (620-02100) and in accordance with the attached **Construction Schedule of Assessment**.

### **Grant Eligibility**

The Ontario Ministry of Agriculture, Food, and Agribusiness (OMAFRA) has issued Administrative Policies for the Agricultural Drainage Infrastructure Program (ADIP) to provide financial assistance for assessments to eligible agricultural lands pursuant to the Drainage Act.

Based on our investigations, the subject access bridge is being installed within agricultural lands to serve as the primary access to an agricultural property that was involved in a severance after July 28th, 2004. Therefore, the proposed access bridge to the subject lands is unlikely to be eligible for the grant due to the following provisions within the ADIP policies through OMAFA:

1. **Policy 2.3.i(ii)** – Notwithstanding (i) above, any new crossing required as a result of any lot severance that occurred after July 28, 2004, is not eligible for the grant.

Therefore, the assessments related to the construction of the primary access to this property shall be shown in the attached Construction Schedule of Assessment under the Subheading "**5. Privately Owned – Agricultural Lands (non-grantable)**".

### **Distribution of Unforeseen Costs (Special Assessments Section 26)**

During construction, it may become necessary to temporarily or permanently relocate existing utilities that may conflict with the works outlined within this report. Under these circumstances, the relocation of these utilities shall be assessed any relocation costs against the public utility having jurisdiction in accordance with Section 26 of the Drainage Act. In accordance with Section 69 of the Drainage Act, the utility company is allowed the option to carry out this work utilizing their own forces and at their own cost. However, should they not exercise this option within a reasonable time, the Municipality may arrange to have this work completed, and the costs for same shall be charged to the appropriate public utility. Furthermore, any unforeseen construction costs directly related to the Section 26 works shall be assessed entirely, as an extra, to the applicable Road Authority or Utility.

## **X. FUTURE MAINTENANCE**

After the completion of the construction of this primary access bridge, all of the structure shall be maintained in the future by the Town of Kingsville.

If any maintenance work is required in the future to this access bridge, we wish to establish that **71.1%** of the future maintenance costs be assessed as a Benefit to the abutting property being served by this access bridge, which is currently owned by Donald & Shannon Ames (620-02100), in Part of Lot 19, Concession 10. The remaining **28.9%** of the future maintenance costs shall be assessed as an Outlet Liability against the lands and roads lying upstream of the bridge site, within the drain's watershed. The assessment to upstream lands and roads shall be assessed in the same proportions as the Outlet assessment charges shown in the most current governing Schedule of Assessment of the Engineer's Report prepared by William J. Settingington, P.Eng., dated June 18, 1976, or per subsequent amendments made thereto, under the provisions of the Drainage Act.

We recommend that the new access bridge structure, as identified herein, be maintained in the future as part of the drainage works. We would also recommend that this newly constructed legal access bridge in the drain, for which the maintenance costs are to be shared with the upstream lands and roads within the watershed, be maintained by the Municipality, and that said maintenance would include works to the bridge culvert, bedding, backfill and end treatment. Should concrete, asphalt or other decorative driveway surfaces over these bridge culverts require removal as part of the maintenance works, these surfaces should also be repaired or replaced as part of the works. Likewise, if any fencing, gate, decorative walls, guard rails or other special features exist that will be impacted by the maintenance work, they are also to be removed and restored or replaced as part of the bridge maintenance work. However, the cost of the supply and installation of any surface material other than Granular "A" material, and the cost of removal and restoration or replacement, if necessary, of any special features, shall be totally assessed to the benefiting adjoining Owner served by said access bridge.

The above provisions for the future maintenance of this new access bridge, being constructed under this report, shall remain as aforesaid until otherwise determined under the provisions of the "Drainage Act, RSO 1990, Chapter D.17, as amended 2021".

All of which is respectfully submitted,

**N.J. PERALTA ENGINEERING LTD.**



\_\_\_\_\_  
Antonio B. Peralta, P.Eng.

ABP/kk

This page has been intentionally left blank

CONSTRUCTION SCHEDULE OF ASSESSMENT

**5. PRIVATELY OWNED - AGRICULTURAL LANDS (non-grantable):**

Tax Roll Number	Con. or Plan Number	Lot or Part of Lot	Acres Owned	Acres Affected	Hectares Affected	Owner's Name	Value of Benefit	Value of Outlet	TOTAL VALUE
620-02100	10	19	36.00	36.00	14.569	Donald & Shannon Ames	\$ 66,740.00	\$ -	\$ 66,740.00
<b>Total on Privately Owned - Agricultural Lands (non-grantable).....</b>							<b>\$ 66,740.00</b>	<b>\$ -</b>	<b>\$ 66,740.00</b>
<b>TOTAL ASSESSMENT</b>				<b>36.00</b>	<b>14.569</b>		<b>\$ 66,740.00</b>	<b>\$ -</b>	<b>\$ 66,740.00</b>

1 Hectare = 2.471 Acres

This page has been intentionally left blank

# SPECIFICATIONS

This page has been intentionally left blank

**TABLE OF CONTENTS**

I.	General Conditions for Specifications.....	2
II.	Review of Site, Plans, and Specifications .....	2
III.	Maintenance Period .....	3
IV.	Liability of The Contractor .....	3
V.	General Coordination .....	3
VI.	Legal Survey Bars and Monuments .....	3
VII.	Maintaining Conveyance.....	3
VIII.	Approvals, Permitting, and Inspection .....	4
IX.	Traffic Control.....	4
X.	Fencing and/or Structures.....	5
XI.	Benchmarks .....	5
XII.	Environmental Considerations.....	6
XIII.	Final Cleanup and Restoration.....	6
XIV.	General Conditions.....	6

This page has been intentionally left blank

## STANDARD SPECIFICATIONS

General  
(Revised January 2024)

### **I. GENERAL CONDITIONS FOR SPECIFICATIONS**

The specifications, together with the accompanying drawings and appendices, delineate the furnishing of all labour, equipment, materials, and supplies required for the performance of all operations relating to the construction and/or improvements of a Municipal Drain under the most recent revision of the Drainage Act and/or amendments made thereto. These specifications serve to supplement and/or amend the current Ontario Provincial Standard Specifications and Standard Drawings, adopted by the Ontario Municipal Engineers Association. "Special Provisions" are included as part of the overall document and shall be read in conjunction with these standard specifications. Where a discrepancy occurs between the requirements of the Standard Specifications and the Special Provisions, the Special Provisions shall govern. In the event that the Specifications, Information to Tenderers, or the Form of Agreement do not apply to a specific condition or circumstance with respect to this project, the applicable section or sections from the Canadian Construction Documents Committee (CCDC) shall govern and be used to establish the requirements of the work.

Any reference to "Drainage Superintendent" and/or "Consulting Engineer" within this document shall refer to the person (or persons) appointed by the Council of the Municipality having jurisdiction over the drainage works.

All work shall be done in a first-class and workmanlike manner, complete in all respects and including all items specified herein, or as necessary for the accomplishment of a complete, satisfactory, and approved installation.

### **II. REVIEW OF SITE, PLANS, AND SPECIFICATIONS**

As part of the Tender process, each tenderer shall visit the site(s) and review all documentation associated with the project prior to their tender submission and satisfy themselves with the full extent of the scope of work and conditions to complete the project. The Contractor may request, at any time prior to the closing of the tender, to examine any associated information available from the Drainage Superintendent and/or Consulting Engineer. Claims that there are any misunderstandings of the terms and conditions of the Contract related to site conditions will not be permitted.

The quantities identified within the Construction Items, Drawings and/or Specifications are estimates only and are intended for the sole purpose of identifying the general extent of the proposed work. The tenderer shall be responsible to verify the quantities for accuracy prior to submitting their tender.

### **III. MAINTENANCE PERIOD**

The successful tenderer shall guarantee and warrant the work for a period of twelve (12) months from the time that substantial completion is issued. Upon the expiry of the maintenance period, with ordinary wear and tear, the work shall remain in such condition as will meet with the approval of the Consulting Engineer, and it will be responsible for rectification in a manner satisfactory to the Consulting Engineer. The cost thereof, of any imperfect work due to or arising from materials, equipment or plant incorporated into or used in the construction thereof, or due to or arising from workmanship or methods of construction, that is discovered by any means at any time prior to the issuance of the Final Certificate. The Consulting Engineer shall decide as to the nature, extent, cause of, and responsibility for imperfect work and the necessity for and the method of rectification thereof. In the event that the Contractor fails to comply with the above and address any deficiencies, the Municipality may complete these deficiencies, with the guidance of the Consulting Engineer, to make such repairs or complete such works, and the whole costs, charges and/or expenses so incurred may be deducted from any amount due or collected from the Contractor.

### **IV. LIABILITY OF THE CONTRACTOR**

The Contractor, its agents, workforce and/or sub-contractors, shall satisfy itself as to the exact location, nature and extent of any existing structure, utility or other objects that it may encounter during the course of the work. The Contractor will be responsible for any damage caused by it to any person, property, public utilities, and/or municipal infrastructure. The Contractor shall indemnify and save harmless, the Municipality and the Consulting Engineer for any damages which it may cause or sustain during the progress of the work. The Contractor shall not hold the Municipality or the Consulting Engineer liable for any legal action arising out of any claims brought about by such damage caused by it.

### **V. GENERAL COORDINATION**

The Contractor shall be responsible for the coordination with other organizations, agencies, and utility companies in connection with the works. The Contractor shall not take action against the Municipality or the Engineer for delays caused by the site being unavailable to them by the Municipality or Consulting Engineer because of the acts, omissions, conduct or misconduct of other organizations or utility companies engaged in other work.

### **VI. LEGAL SURVEY BARS AND MONUMENTS**

The Contractor is to note that legal survey bars may exist within the work site, and it shall take whatever steps necessary to protect these features. If any iron bar or monument is damaged or removed by the Contractor, it shall arrange for an Ontario Land Surveyor licensed in the Province of Ontario to restore same, all at the Contractor's expense.

### **VII. MAINTAINING CONVEYANCE**

The drainage works shall not be conducted at times when flows in the drain are elevated due to local rain events, storms, or seasonal floods. Work shall be completed during times when the drain is dry or frozen.

When performing excavation work, care should be taken not to interfere with, plug up, or damage any existing surface drains, swales, and lateral or main tile ends. The Contractor shall be responsible to maintain permanent flow at all times. Temporary damming of flow is permitted to conduct the necessary works. However, the Contractor is responsible to monitor and ensure no damage occurs as a result of its actions. Under no circumstances shall temporary damming be permitted for an extended period (ie. overnight, etc.) without a suitable water control plan approved by the Drainage Superintendent, Consulting Engineer and/or the Conservation Authority.

#### **VIII. APPROVALS, PERMITTING, AND INSPECTION**

The works proposed under this project is subject to the approval, inspection, regulations, and by-laws of all Municipal, Provincial, and Federal entity, or any other agency having jurisdiction associated with the drainage works established herein. The Contractor shall ensure that all applicable permits and approvals are procured from all affected authorities prior to carrying out any of the prescribed works identified within the Contract, or in the vicinity of any public utility, railway and/or road authority.

The drainage works forming part of this project, including all appurtenances, shall be completely inspected by the Town Drainage Superintendent and/or the Consulting Engineer's Inspector prior to its completion. Under no circumstance shall the Contractor commence the construction or backfill of any underground feature without the site presence of the Drainage Superintendent and/or the Consulting Engineer's Inspector to inspect and approve said installation. The Contractor shall provide a minimum of forty-eight (48) hours' notice to the Drainage Superintendent and/or the Consulting Engineer prior to the commencement of the work. All works shall be performed during normal working hours of the Drainage Superintendent and/or the Consulting Engineer from Monday to Friday unless written authorization is provided by them to amend these working hours.

Upon completion of the works and prior to the demobilization and removal of all equipment and materials from the site, the Contractor shall notify the Drainage Superintendent and/or Consulting Engineer to arrange a final inspection of the works. The final inspection is intended to ensure that all aspects of the drainage work are satisfactorily completed and/or identify any outstanding deficiencies. Any outstanding deficiencies shall be addressed expeditiously as weather permits.

#### **IX. TRAFFIC CONTROL**

The Contractor shall ensure that the travelling public is always protected while utilizing the roadway for its access. The Contractor shall be required to carry out all the necessary steps to direct traffic and provide temporary diversion of traffic around work sites, including provision of all lights, signs, flag persons, and barricades required to protect the safety of the travelling public. The Contractor shall be required to submit a Traffic Control Plan to the Consulting Engineer for approval from the governing Road Authorities. The Traffic Control Plan shall be carried out in accordance with the requirements of the Ontario Traffic Manual's Book 7 for Temporary Conditions. Should the Contractor have to close any roads for the proposed works, it shall arrange to obtain the necessary authorizations from the Municipality, County, or Provincial Roads Departments (if applicable) and distribute notification of detours around the site. The Contractor shall also ensure that all emergency services, school bus companies, etc. are contacted about the disruption to access

at least 48 hours in advance of same. All detour routes shall be established in consultation with the Municipality and County Roads Department (if applicable).

Due to the extent of the work and the area for carrying out the work, the Contractor shall be required to carry out all of the necessary steps to direct traffic and provide temporary diversion of traffic around work sites, including the provision of all lights, signs, flag persons, and barricades required to protect the safety of the travelling public. Any accesses or areas used in carrying out the works are to be fully restored to their original conditions by the Contractor, including topsoil placement and lawn restoration as directed by the Drainage Superintendent and/or the Consulting Engineer. Restoration shall include but not be limited to all necessary levelling, grading, shaping, topsoil, seeding and mulching, and granular placement required to make good any damage caused.

The Contractor shall note that any deviation from the specified access for the construction of the culvert without the explicit approval of the adjacent landowners and the Drainage Superintendent could result in the Contractor being liable for damages sustained. The value for such damage shall be determined by the Drainage Superintendent and the Consulting Engineer and be subsequently deducted from the Contract Price. Where applicable, the Contractor shall be responsible for any damage caused by them to any portion of the road right-of-way. They shall take whatever precautions are necessary to avoid damage to the roadway. Any damage to the roadway must be restored to its' original condition upon completion of the works.

#### **X. FENCING AND/OR STRUCTURES**

Where it is necessary to take down any fence and/or structure to proceed with the work, same shall be done by the Contractor across or along that portion of the work where such fence and/or structure is located. The Contractor shall be required to exercise extreme care in the removal of any fencing and/or structure, to ensure minimum damage to same. The Contractor shall be required to replace any fence and/or structure that is taken down in order to proceed with the work, and the fence and/or structure shall be replaced in a neat and workmanlike manner. The Contractor shall not be required to procure any new materials for rebuilding the fence and/or structure provided that it has used reasonable care in the removal and replacement of same. When any fence and/or structure is removed by the Contractor, and the Owner thereof deems it advisable and procures new material for replacing the fence and/or structure so removed, the Contractor shall replace the fence and/or structure using new materials and the materials from the present fence and/or structure shall remain the property of the Owner.

#### **XI. BENCHMARKS**

For use by the Contractor, Benchmarks have been established along the course of the work. The plans include details illustrating the available Benchmarks and the work to be carried out. Benchmarks have been indicated and the Elevations have been shown and shall be utilized by the Contractor in carrying out its work. The Contractor shall note that specific design elevations and grades have been provided for the proposed works. The plans also set out side slopes, bottom width, and other requirements relative to its installation. In all cases, the Contractor is to utilize the specified Benchmarks to establish the identified elevations and grades. The Contractor shall ensure that it takes note of the direction of flow and sets all grades to match the direction of flow within the drain.

## **XII. ENVIRONMENTAL CONSIDERATIONS**

Prior to commencing work, the Contractor must familiarize themselves with all associated environmental approvals and mitigations. The Contractor shall review the results of any environmental reviews performed for the project, including documents for the purpose of identification of known Species at Risk within the project area and mitigation measures for species and habitat protection. It is the responsibility of the Contractor to make certain that necessary provisions are undertaken to ensure the protection of all Species at Risk and their habitats throughout the course of construction. The Contractor will be responsible for providing the necessary equipment and materials required by any mitigation plans and shall contact the Drainage Superintendent immediately if any Endangered Species are encountered during construction.

## **XIII. FINAL CLEANUP AND RESTORATION**

The whole of the work shall be satisfactorily cleaned up, and during the course of the construction, no portion shall be left in any untidy or incomplete state before subsequent portions are undertaken. Following the completion of the work, the Contractor is to trim up any broken or damaged limbs on trees which are to remain standing, and it shall dispose of said branches along with other brush, thus leaving the trees in a neat and tidy condition. The whole of the work shall be satisfactorily cleaned up, and during the course of the construction, no work shall be left in any untidy or incomplete state before subsequent portions are undertaken.

Any accesses or areas used in carrying out the works are to be fully restored to their original conditions by the Contractor, including topsoil placement and lawn restoration as directed by the Drainage Superintendent and/or the Consulting Engineer. Restoration shall include, but not be limited to, all necessary levelling, grading, shaping, topsoil, seeding and mulching, and granular placement required to make good any damage caused. Any damages caused, resulting from non-compliance with the above-noted provisions, shall be restored by the Contractor to its original condition, at the Contractor's expense. All roadways, driveways and access bridges, or any other means of access onto the job site shall be fully restored to their former condition at the Contractor's expense. In the event that the Contractor fails to satisfactorily clean up any portion of these accesses, the Consulting Engineer shall order such cleanup to be carried out by others and the cost of same to be deducted from any monies owing to the Contractor.

## **XIV. GENERAL CONDITIONS**

- a) The Drainage Superintendent or Consulting Engineer shall have the authority to carry out minor changes to the work where such changes do not lessen the efficiency of the work.
- b) The Contractor shall provide a sufficient number of layout stakes and grade points so that the Drainage Superintendent and Consulting Engineer can review same and check that the work will generally conform with the design and project intent.
- c) The Contractor will be responsible for any damage caused by it to any portion of the Municipal Road system, especially to the travelled portion. When excavation work is being carried out and the excavation equipment is placed on the travelled portion of the road, the travelled portion shall be protected by having the excavation equipment placed on satisfactory timber planks or timber pads. If

any part of the travelled portion of the road is damaged by the Contractor, the Municipality shall have the right to have the necessary repair work done by its employees and the cost of all labour and materials used to carry out the repair work shall be deducted from the Contractor's contract and credited to the Municipality. The Contractor, upon completing the works, shall clean all debris and junk, etc., from the roadside of the drain, and leave the site in a neat and workmanlike manner. The Contractor shall be responsible for keeping all public roadways utilized for hauling materials free and clear of mud and debris.

- d) The Contractor will be required to submit to the Municipality, a Certificate of Good Standing from the Workplace Safety and Insurance Board prior to the commencement of the work and the Contractor will be required to submit to the Municipality, a Certificate of Clearance for the project from the Workplace Safety and Insurance Board before Final Payment is made to the Contractor.
- e) The Contractor shall furnish a Performance and Maintenance Bond along with a separate Labour and Material Payment Bond within ten (10) days after notification of the execution of the Agreement by the Owner unless otherwise established within the Tender Documents. One copy of said bonds shall be bound into each of the executed sets of the Contract. Each Performance and Maintenance Bond and Labour and Material Payment Bond shall be in the amount of 100% of the total Tender Price. All Bonds shall be executed under corporate seal by the Contractor and a surety company, authorized by law to carry out business in the Province of Ontario. The Bonds shall be acceptable to the Owner in every way and shall guarantee faithful performance of the contract during the period of the contract, including the period of guaranteed maintenance which will be in effect for twelve (12) months after substantial completion of the works.

The Tenderer shall include the cost of bonds in the unit price of the Tender items as no additional payment will be made in this regard.

- f) The Contractor shall be required, as part of this Contract, to provide Comprehensive Liability Insurance coverage for not less than \$5,000,000.00 on this project unless otherwise established in the Tender Documents, and shall name the Municipality and its' officials, and the Consulting Engineer and its staff as additional insured under the policy. The Contractor must submit a copy of this policy to both the Municipal Clerk and the Consulting Engineer prior to the commencement of work.
- g) Monthly progress orders for payment shall be furnished the Contractor by the Drainage Superintendent. Said orders shall be for not more than 90% of the value of the work done and the materials furnished on the site. The paying of the full 90% does not imply that any portion of the work has been accepted. The remaining 10% will be paid 60 days after the final acceptance and completion of the work and payment shall not be authorized until the Contractor provides the following:
  - i) a Certificate of Clearance for the project from the Workplace Safety and Insurance Board
  - ii) proof of advertising
  - iii) a Statutory Declaration, in a form satisfactory to the Consulting Engineer and the Municipality, that all liabilities incurred by the Contractor and its Sub-Contractors in carrying out the Contract have been discharged and that all liens in respect of the Contract and Sub-Contracts thereunder have expired or have been satisfied, discharged or provided for by payment into Court.

The Contractor shall satisfy the Consulting Engineer or Municipality that there are no liens or claims against the work and that all of the requirements as per the Construction Act, 2018 and its' subsequent amendments have been adhered to by the Contractor.

This page has been intentionally left blank

## TABLE OF CONTENTS

I.	General Information for Specifications.....	2
II.	Removal of Brush, Trees, and Debris.....	2
III.	Utilities.....	3
IV.	Notice of Project Commencement and Hours of Operation.....	3
V.	Excavations, Removals and Disposals.....	4
VI.	Pipe Installation.....	4
VII.	Drainage Structure Installation.....	6
VIII.	Culvert Backfill.....	7
IX.	Bridge End Protection.....	8
X.	Sloped Quarried Limestone Erosion Protection for Vertical Headwalls.....	11
XI.	Ancillary Work.....	11
XII.	Topsoil, Seed and Mulch.....	12
XIII.	Final Cleanup and Restoration.....	13

## DETAILS

Figure 1 - Flotation Anchor Details.....	14
Figure 2 - Typical Driveway Crossing Backfill Detail.....	15
Figure 3 - Typical Quarried Limestone End Protection Detail.....	15
Figure 4 - Typical Precast Interlocking Concrete Block Vertical Headwall End Protection Detail.....	16
Figure 5 - Typical Concrete Filled Double Jute Bag Headwall End Protection Detail.....	16
Figure 6 - Typical Concrete Filled Jute Bag Headwall End Protection Detail.....	17
Figure 7 - Standard Lateral Tile Detail.....	17

This page has been intentionally left blank

## STANDARD SPECIFICATIONS FOR NEW ACCESS BRIDGE INSTALLATIONS

(Revised March 2025)

### **I. GENERAL INFORMATION FOR SPECIFICATIONS**

These specifications, together with the accompanying drawings and appendices, delineate the furnishing of all labour, equipment, materials, and supplies required for the performance of all operations relating to the construction and/or improvements of a Municipal Drain under the most recent revision of the Drainage Act and/or amendments made thereto. These specifications serve to supplement and/or amend the current Ontario Provincial Standard Specifications and Standard Drawings, adopted by the Ontario Municipal Engineers Association. "Special Provisions" are included as part of the overall document and shall be read in conjunction with these Standard Specifications. Where a discrepancy occurs between the requirements of the Standard Specifications and the Special Provisions, the Special Provisions shall govern. In the event that the Specifications, Information to Tenderers, or the Form of Agreement do not apply to a specific condition or circumstance with respect to this project, the applicable section, or sections from the Canadian Construction Documents Committee (CCDC) shall govern and be used to establish the requirements of the work.

Any reference to "Drainage Superintendent" and/or "Consulting Engineer" within this document shall refer to the person (or persons) appointed by the Council of the Municipality having jurisdiction over the drainage works.

All work shall be done in a first-class and workmanlike manner, complete in all respects and including all items specified herein, or as necessary for the accomplishment of a complete, satisfactory, and approved installation.

### **II. REMOVAL OF BRUSH, TREES, AND DEBRIS**

Where there is any brush, trees, or debris along the course of the drainage works, including the full width of the access, all such brush, trees or debris shall be close-cut and grubbed out, and the whole shall be chipped up for recycling, burned, hauled away or satisfactorily disposed of by the Contractor at its expense. Prior to and during the course of the burning operations, the Contractor shall comply with the guidelines prepared by the Air Quality Branch of the Ontario Ministry of the Environment and shall ensure that the Environmental Protection Act is not violated. The Contractor will be required to notify the local fire authorities and cooperate with them in the carrying out of any work. The removal of brush and trees shall be carried out in close consultation with the Drainage Superintendent or Consulting Engineer to ensure that no decorative trees or shrubs are disturbed by the operations of the Contractor that can be saved. It is the intent of this project to save as many trees and bushes as practical within the roadway allowances and on private lands.

The Contractor shall protect all other trees, bushes, and shrubs located along the length of the drainage works except for those trees that are noted within the accompanying drawings or in consultation with the

Drainage Superintendent, the Consulting Engineer, and the affected Owner(s). The Contractor shall note that protecting and saving the trees may require the Contractor to carry out handwork around the trees, bushes, and shrubs to complete the necessary final site grading and restoration.

Following the completion of the work, the Contractor is to trim up any broken or damaged limbs on trees which are to remain to stand, and it shall dispose of said branches along with other brush, thus leaving the trees in a neat and tidy condition.

The Contractor shall remove all deleterious materials and debris along the course of the open drain and any such materials located in the bridge culverts while carrying out its cleaning of same. All such deleterious materials and debris shall be loaded up and hauled away by the Contractor to a site to be obtained by it at their expense.

If applicable, where identified on the drawings, and to ensure a safe separation distance is maintained, the Contractor shall install tree protection fencing at the projected limit of the excavation and beneath the drip line of the identified tree(s). The fencing shall be comprised of orange vinyl snow fencing secured at 3.00-metre intervals with iron T-posts driven 600mm into the ground and should be in place until construction work is completed. During construction, no equipment, materials, or tools shall be stored beyond the tree protection fencing.

### **III. UTILITIES**

The Contractor will be responsible at all times for complete investigation to determine the location of all such utilities or structures known or unknown, and it shall indemnify and save harmless the Engineer and the Municipality for any responsibility, injury, or liability arising from any damage to such utilities or structures by the Contractor.

The Contractor shall protect all other services located in the vicinity of the proposed drainage works including any sanitary sewers and connections, watermains and connections, telephone and gas services, along with any private systems and services. Any damaged components shall be replaced by the Contractor, totally at its own expense and it shall fully restore the functionality of same.

The Contractor shall further contact or notify such Utility Company or Commission of its intention to carry out work in the area and cooperate with such Utility Company or Commission in the location, maintenance and preservation of all such utilities. The location of the pipes and appurtenances as shown on the drawings is approximate and may be changed by the Engineer if deemed advantageous for the progress of the work.

### **IV. NOTICE OF PROJECT COMMENCEMENT AND HOURS OF OPERATION**

The Contractor shall provide a minimum of forty-eight (48) hours' notice to the Drainage Superintendent and/or the Consulting Engineer prior to the commencement of the work. The installation of the culvert structure is to be performed during normal working hours of the Drainage Superintendent and/or the Consulting Engineer from Monday to Friday unless written authorization is provided by them to amend such working hours.

## **V. EXCAVATIONS, REMOVALS AND DISPOSALS**

All excavation shall be made in compliance with the drawings and in such a manner and at such depths and widths as will give ample room for installing the pipe, the bracing, sheeting, or otherwise supporting the sides of the excavation and for the pumping of groundwater if encountered. The Contractor is fully responsible for the safety of all its men and equipment and must conform completely with the provisions of the "Construction Safety Act" and "Regulations for Construction Projects".

Where an existing culvert is being replaced, the Contractor shall be required to excavate and completely remove the existing culvert and headwalls in their entirety, as well as any other deleterious materials that may be encountered in removing such materials, unless otherwise noted. All unsuitable or deleterious materials from the excavation and removal of existing culverts and the drain shall be hauled away and disposed of by the Contractor to a site to be obtained by it at its own expense. In all cases, the disposal of any trucked material will be the responsibility of the Contractor and it shall ensure that any permits required for fill disposal are obtained from the appropriate authority. The Contractor will be responsible for keeping all private and public roadways free and clear of mud and debris resulting from its use of same for access and hauling purposes.

The Contractor is to note that when replacing the existing structures, it shall be required to excavate a trench having a width not less than the new pipe outside diameter plus a 600mm working width on both sides of the new pipe.

During the course of its excavation operations, the Contractor will be required to salvage all available topsoil. Where necessary, this material shall be stockpiled by the Contractor in order to avoid contamination and shall be utilized in carrying out any topsoil placement along all specified or disturbed areas, in preparation for the seeding and mulching operation to be carried out as part of the restoration works.

The bottom of the trenches must be carefully excavated and trimmed to the elevation and shape of the bottom of the pipe. The bottom of the trenches shall be recessed to receive the pipe in order to allow the pipe to be uniformly supported for its entire length. Corrections in the depth of excavation caused by the Contractor excavating to an extent greater than that required for the elevation of the pipe shall be made by bedding the pipe with 20mm (3/4") clear stone granular material is placed at the time that the pipes are being installed, at the Contractor's expense.

No extras will be allowed for excavating any hardpan, boulders, rocks, ice or other obstacles found in the excavation or in the line of the trench or for any pumping or baling of water required in the excavation of the work. The trench must be drained or pumped in order to avoid the necessity of making joints under water. The trench must also be drained to avoid any possibility of groundwater entering the pipe in the trench until the installation has been successfully completed.

## **VI. PIPE INSTALLATION**

The new pipe shall be set in the alignment and to the grade elevations established in the accompanying drawings. The same shall not be altered unless otherwise directed by the Drainage Superintendent or Consulting Engineer prior to construction of same. Any changes relative to the culvert must be approved by the Consulting Engineer prior to proceeding with construction.

The Contractor shall lay the culvert pipe to the lines, levels, and grades as shown in the accompanying drawings or as may be laid out and established by the Engineer prior to the time of construction. The Contractor shall be held responsible for said lines, levels and grades of the pipe and should the Engineer determine that the Contractor has not satisfactorily adhered to such lines, levels and grades, it may direct the Contractor to take up and re-lay any portion of the drain which does not conform to such lines, levels and grades. In the event that the required pipe length is less than 6.10 metres (20.00 ft.), the smaller length must be installed near the centre of the culvert.

Laser control must be provided to maintain drain lines and grades, and the Contractor shall have a qualified Operator to set up and operate the equipment. In some instances, but only at the discretion of the Engineer, an approved system of batter boards may be utilized for this purpose; However, the cost of placing grade stakes and determining the cut information shall be provided by or paid for entirely by the Contractor.

The Contractor should note that, because the pipe is being installed with an excavator, it is expected that they will provide a minimum of 150mm (6") of either compacted MTO Granular "A", Granular "B" (Type II) or 20mm (3/4") clear stone bedding material, as outlined within OPSS Form 1010 The Contractor shall ensure that a good firm base is provided under the drain pipe, and they shall provide for this item as part of their tender price.

### **HDPE Pipe Installation**

When HDPE plastic pipes are specified, they shall be joined together with the use of a water-tight bell and gasket joining system, secured in accordance with the Manufacturer's recommendations. The minimum length of a continuous pipe section shall be no less than 6.10 metres (20.00 ft.). The HDPE plastic pipe for this installation must be of the length, size, and strength identified in the Drawings, Special Provisions, and approved by the Drainage Superintendent and the Consulting Engineer prior to its placement in the drain.

For new smoothwall HDPE culvert pipes that are shown on the Drawings to have sloped quarried limestone erosion protection at their ends, both ends of the pipe shall be securely anchored against floatation utilizing two (2) steel T-bar fence posts having a minimum length of 1.80 metres (6.00 ft.) or approved equal, on each side of the pipe, together with heavy steel galvanized wire secured between them across the top of the pipe. The top of each post shall be set no higher than the top of the proposed culvert. Pipe anchors shall be installed in accordance with the "**Floatation Anchor Details**" outlined herein.

### **Aluminized Steel Pipe Installation**

When Aluminized Steel Corrugated Hel-Cor pipe and/or Aluminized Steel Type II UltraFlo pipe is specified, the culvert shall be installed with a minimum number of couplers and longer pipe sections are to be utilized whenever possible. Under no circumstances shall the culvert sections be less than 4.00 metres in length. All pipe lengths shall be of the size and gauge noted in the drawings and shall be coupled together with Aluminized Steel Type II 10C having a thickness consistent with the culvert pipe material. The overall pipe for this installation must be of the length, size, and thickness as identified in the Drawings, Special Provisions, and approved by the Drainage Superintendent and/or the Consulting Engineer prior to its placement in the drain.

### **General Pipe Installation**

The Contractor shall be required to provide all labour, equipment, and materials to set the pipe to the required design grades. Where couplers are required, the Contractor shall utilize the appropriate coupler provided by

and per the specifications of the Manufacturer. The Contractor shall supply all material and labour to provide a non-woven filter cloth wrap around the full circumference of the coupler joint connection, as part of their tender price. The filter cloth wrap connection shall be a minimum of 250mm (10") wider than the width of the proposed coupler and shall overlap a minimum of 200mm (8"), as available from Underground Specialties Inc., of Windsor, Ontario, or equal. The specific type to be utilized shall be approved by the Drainage Superintendent and/or the Consulting Engineer prior to its placement. The installation of all joints must be inspected and approved by the Drainage Superintendent or Consulting Engineer prior to any backfilling of same.

The Contractor shall also note that the placement of the culvert is to be performed totally in the dry, and it shall be prepared to take whatever steps are necessary to ensure same, all to the satisfaction of the Drainage Superintendent and/or Consulting Engineer. The installation of the complete length of pipe, including all appurtenances, shall be completely inspected by the Drainage Superintendent and/or the Consulting Engineer's Inspector prior to backfilling any portions of same. Under no circumstance shall the Contractor commence the construction or backfill of the pipe without the site presence of the Drainage Superintendent and/or the Consulting Engineer's Inspector to inspect and approve said installation.

All pipe materials shall be stored and handled by the Contractor at its own expense. It shall be responsible for the safe storage of all materials, for obtaining storage areas, for the safe transportation and distribution of all the materials at the job site, and for inspection in order to determine defects and breakage. No additional recompense will be allowed to the Contractor for any loss incurred by it in the storage and handling of the materials.

Pipe, fittings, and all accessory appurtenances must be loaded and unloaded by lifting with means of a hoist or a skid to avoid shock or damage. Under no circumstances shall any drain material or materials for drain appurtenances be dropped.

If the culvert is laid in freezing weather, the Contractor shall take all the necessary precautions to prevent damage to the pipe or to any of the materials used in the construction of the work. In addition, the Contractor shall take care that no frozen ground or backfill is placed in the trench backfilling adjacent to the culvert. All pipe and the various other materials used in the placing of said pipe shall be installed in strict compliance with the Manufacturer's recommendations.

The installation of the complete length of the new culvert pipe, including all appurtenances, shall be completely inspected by the Drainage Superintendent and/or the Consulting Engineer's Inspector prior to backfilling any portions of same. Under no circumstance shall the Contractor commence the construction or backfill of the culvert pipe without the site presence of the Drainage Superintendent and/or the Consulting Engineer's Inspector to inspect and approve the said installation.

## **VII. DRAINAGE STRUCTURE INSTALLATION**

Where required, all materials for the catch basins shall comply with Ontario Provincial Standard Specifications (OPSS) and Ontario Provincial Standard Drawings (OPSD) with respect to materials, qualities, and installation details. The catch basins and maintenance holes shall be founded on a good, dry, firm, undisturbed earth base for its entire bottom surface area, or 20mm (3/4") clear stone bedding, if necessary. Corrections in depth of excavation caused by the Contractor excavating to an extent greater than that required for the structures shall

be backfilled to the proper grade elevation by embedding the catch basin maintenance holes floor area with 20mm (3/4") clear stone granular bedding. A sump is to be provided in each structure which shall be a minimum of 450mm deep measured from the proposed invert of the covered drain or connection to the proposed concrete floor elevation of the structure. The structure shall be set to allow for connection of all of the inlet and outlet pipes and shall be installed as shown and detailed on the Drawings. The top elevation of the structure shall be installed to the elevations noted on the Drawings or as further directed by the Drainage Superintendent or the Consulting Engineer. All structure sections and adjustment units shall be joined together with standard gasket material, caulking, or grout as required by the Manufacturer, or as set out in the applicable OPSS and OPSD.

All structures, where applicable, shall include a minimum of two (2) adjustment units in accordance with OPSD 704.011. All work shall be completed as shown and detailed on the Drawings.

The Contractor shall connect all covered drains and connections in the catch basin maintenance holes with the use of a mortar joint or standard rubber boot cast into the units by the Manufacturer. Said mortar joint shall be provided at the internal and exterior of the catch basin maintenance holes wall for the full circumference of the covered drain and be of a sufficient mass to produce a sealed joint, all to be performed to the satisfaction of the Drainage Superintendent or the Consulting Engineer. Where possible, the Contractor shall employ a standard factory fitting or adapter to connect between the various pipes, tiles, and catch basin maintenance holes, otherwise a mortar joint connection can be utilized.

#### **VIII. CULVERT BACKFILL**

Where the new culvert pipe is located under the driveway, the Contractor shall backfill the entire trench for the width of the driveway with Granular "B" (Type II) or Granular "A", or locally approved equivalent compacted in place to a minimum 98% of Standard Proctor Density with the exception of the top 300mm which should be backfilled with Granular "A" material also compacted in place to a Standard Proctor Density of 100%. Where the new culvert pipe is located along the lawn area, the Contractor shall be required to backfill the entire trench with good clean native backfill material with the exception of the top 100mm which shall be good clean black loamy topsoil readied for seeding and mulching. It should be noted that if there is a shortage of native backfill material available, the Contractor shall supply same all at its own expense. The Contractor should also note that prior to commencing its excavation that all existing topsoil should be scavenged for reuse on the project; if there is a shortage, the Contractor shall be required to supply the balance of the topsoil needed, all at its own expense. All of the native backfill material shall be compacted in place to a minimum Standard Proctor Density of 96%.

All backfill material shall be placed in compacted in maximum lifts of approximately 300mm thick. The Contractor is required to provide whatever mechanical equipment necessary, such as jumping jack and/or plate tamper, in order to achieve the necessary compaction levels, especially along the haunches of the new pipe. All areas shall be graded in accordance with the profile and cross-sections shown in the accompanying drawings, including provision of cross-fall on boulevard areas as shown and detailed in accordance with the **"Typical Driveway Crossing Backfill Detail"** outlined herein.

## **IX. BRIDGE END PROTECTION**

### **Sloped Quarried Limestone Erosion Protection**

When specified, the Contractor shall install sloped quarried limestone end protection at both ends of the pipe, or where shown, on a slope no steeper than 1.50 horizontal to 1.00 vertical and shall extend from the end of the new pipe to the top elevation shown. The top 305mm (12") of backfill material over the ends of the pipe, from the invert of said pipe to the top of the driveway elevation of the culvert, shall be quarried limestone. The quarried limestone to be placed on the sloped ends of the culvert shall be underlain with a synthetic non-woven geotextile filter fabric. The sloped quarried limestone protection is to be rounded as shown on the plan details and shall also extend along the drain side slopes to a point directly in line with the ends of the culvert pipe. All work shall be completed to the satisfaction of the Drainage Superintendent and/or the Consulting Engineer.

The quarried limestone shall be provided as shown and detailed and shall vary in size from a minimum of 100mm (4") to a maximum of 250mm (10"). The quarried limestone pieces shall be carefully tamped into place with the use of a shovel bucket so that, when complete, the quarried limestone erosion protection shall be consistent, uniform, and tightly laid in place. Prior to placing the quarried limestone, the Contractor shall place non-woven geotextile filter fabric "MacTex MX140" conforming to OPSS 1860 Class 1 or approved equal, as an underlay underneath all areas to be covered in quarried limestone erosion protection. The Contractor shall take extreme care not to damage the geotextile filter fabric when placing the quarried limestone. The placement of the geotextile filter fabric and the quarried limestone, and the completion of the quarried limestone erosion protection shall be conducted to the satisfaction of the Drainage Superintendent and/or Consulting Engineer. Sloped quarried limestone erosion protection shall be installed in accordance with the "**Typical Quarried Limestone End Protection Detail**" outlined herein.

### **Precast Interlocking Concrete Block Headwalls**

When precast interlocking concrete block headwalls are specified, the concrete blocks shall be rectangular in shape with square corners and be a minimum size of 600mm x 600mm x 1200mm (2' x 2' x 4'), as available from Underground Specialties Inc./Wolseley Inc. (Canada) or approved equal. Blocks with modified lengths may be utilized to fill in staggered sections of the block wall. All blocks shall be cast in one pour with no cold joints and shall have a minimum compression strength of 20MPa at 28 days. All precast concrete blocks shall be formed with interlocking pockets and tenons and each block shall be assembled in a staggered formation to prevent sliding at the interface between blocks. All precast concrete blocks shall be uniform in size with relatively smooth and consistent joints and shall have a stone exterior finish. Each block shall be fitted with a lifting ring that will not interfere with the assembly of the block wall once they are set in place. Cap blocks shall be utilized on the top course of the wall with the top of the cap blocks having a stone exterior finish. The precast interlocking concrete block headwalls are available from Underground Specialties Inc./Wolseley Inc. (Canada) or approved equal.

Precast interlocking blocks that abut the pipe shall be cast as one solid piece and shall be cut and shaped to fit closely around the perimeter of the pipe. The face of the wall shall not extend beyond the end of the pipe. All minor gaps between the blocks and the pipe shall be sealed with no shrink grout for the full depth of the blocks. At the base of the wall, a base block shall be used at the bottom of the interlocking block wall. The base block shall be founded on a firm solid base. When necessary, the Contractor shall provide a minimum of 200mm thickness of level compacted granular bedding, or a lean concrete footing, as a firm foundation for the blocks. The base block shall be set level and shall convey a vertical projection throughout its full height and shall include

filter cloth behind the wall for the full height of the blocks to prevent soil migration through any joints. Filter cloth fabric shall be non-woven geotextile material and be minimum "MacTex MX140" meeting OPSS Class I. Both headwalls shall be assembled concurrently with a continuous uni-axial geogrid SG350, or equal, installed across the entire structure at every second course of blocks, to tie each headwall to the other. In the event that the distance between headwalls exceeds 10.00 metres (32.81 ft.), the Contractor shall install the uni-axial geogrid for a distance of 3.00 metres (9.84 ft.) inward from each headwall and at every second course. Both the non-woven filter cloth and the uni-axial geogrid are available from Armtex Construction Products or approved equal.

The blocks shall extend up from the pipe invert and cross the full width of the drain and be embedded a minimum of 500mm into the drain banks. Where required for the top of the block wall to match the height of the completed driveway, the Contractor shall embed the bottom course of blocks into the drain bottom at the appropriate depth to achieve the required top elevation of the wall.

**The Contractor shall arrange for the Supplier to provide interlocking block layout drawings outlining block assembly of the proposed headwall to the Consulting Engineer for approval prior to proceeding with fabrication and assembly of same.** The Contractor shall arrange with the Supplier for technical assistance with the assembly of the structure on-site in full accordance with the requirements of the Supplier. All assembly installation shall be carried out to avoid any damage to the pipe and shall follow the Supplier's recommendation in every respect to ensure a proper and safe installation.

The precast interlocking concrete block headwalls shall be installed vertically and shall extend from the end of the new pipe to the top elevation of the driveway. Under no circumstances shall the interlocking block wall be installed with an outward projection. When complete, the outside face of the headwall shall be installed flush with the end of the proposed culvert. The precast interlocking concrete block headwall shall be installed perpendicular to the drain banks. Headwalls are to be installed so that daylighting is provided off the travelled roadway if required. The daylighting is to be designed to deflect outwardly from approximately the extreme roadside face of the new culvert to a point just beyond the top bank of the drain. The outward projection of the new headwalls shall be deflected at approximately a 45-degree angle, and the maximum outward deflection shall not be greater than shown on the accompanying Drawings, parallel to the projection of the straight portion of the finished wall. The straight portion of the precast interlocking concrete block headwall shall be installed perpendicular to the drain banks. The Contractor shall also be required to backfill the area behind the new headwall with granular fill.

The Contractor shall also be required to satisfactorily backfill the area in behind the new headwall with granular fill as already specified in the preceding paragraphs for backfilling of the bridge culvert. The top elevation of the headwalls, opposite the travelled roadway, are to be set no less than 75mm (3"), below the existing ground elevation unless shown on the drawings. The alignment of these headwalls shall be performed to the satisfaction of the Drainage Superintendent or the Consulting Engineer. Block Headwalls shall be installed in accordance with the "**Precast Interlocking Concrete Block Headwall End Protection Details**" outlined herein.

Provided that the proposed headwall design complies with the provisions outlined under this heading, together with "Figure 4 – Typical Precast Interlocking Concrete Block Vertical Headwall End Protection Detail," the submission of the headwall shop drawings will not require a third-party Engineer's seal. However, if an alternative headwall design is proposed that deviates from the established specifications, the shop drawings

shall bear the seal and signature of an Engineer certifying that the design meets the minimum design standards and includes fabrication details, hardware, reinforcing schedules, etc. for review and approval.

Upon completion of the headwall installation, the Contractor shall also provide sloped quarried limestone erosion protection adjacent and along all of the new concrete headwalls, at the general locations and to the widths shown within the details included therein. Furthermore, the installation of the quarried limestone shall adhere to the parameters outlined in **Section IX. Sloped Quarried Limestone Erosion Protection – Concrete Block Headwalls.**

### **Concrete-Filled Jutebag Headwalls**

When specified, the Contractor shall install new concrete jute bag headwalls at the locations and parameters indicated on the drawing. When constructing the concrete jute bag headwalls, the Contractor shall place the bags so that the completed headwall will have an inward batter from the bottom of the pipe to the top of the finished headwall. The slope of the headwall shall be one (1) unit horizontal to five (5) units vertical. The Contractor shall satisfactorily backfill behind the jutebag headwalls with granular material similar to the rest of the structure, and the same compaction levels specified herein for backfilling the adjacent culvert. The placing of the jute bag headwalls and the backfilling shall be performed in lifts simultaneously. The granular backfill shall be placed and compacted in lifts not to exceed 305mm (12") in thickness.

The concrete jute bag headwalls shall be constructed by filling jute bags with concrete. All concrete used to fill the jute bags shall have a minimum compressive strength of 21MPa in 28 days and shall be provided and placed only as a wet mix. Under no circumstance shall the concrete to be used for filling the jute bags be placed as a dry mix. The jute bags, before being filled with concrete, shall have a dimension of 460mm (18") x 660mm (26"). The jute bags shall be filled with concrete so that when they are laid flat, they will be approximately 100mm (4") thick, 305mm (12") to 380mm (15") wide and 460mm (18") long. The completed jute bag headwalls shall be securely embedded a minimum of 500mm (20") measured perpendicular to the side slopes of the drain.

If indicated on the Drawings, daylighting may be installed off the travelled roadway, and the same are designed to deflect outwardly. The outward deflection shall be deflected at the specified angle to the straight portion of the finished headwall. The top elevations of the daylighted headwalls are to be set no less than 75mm (3") below the existing ground elevation unless otherwise designed. The alignment of these headwalls shall be performed to the satisfaction of the Drainage Superintendent or Consulting Engineer.

Upon completion of the jute bag headwall the Contractor shall cap the top row of concrete-filled bags with a layer of plain concrete, minimum 150mm (6") thick, and hand trowelled to obtain a brushed finish appearance. If the cap is made more than 150mm thick, the Contractor shall provide two (2) continuous 15M reinforcing bars (or equivalent mesh) set at mid-depth and equally spaced in the cap. The Contractor shall fill all voids between the concrete-filled jute bags and the corrugated steel pipe with concrete, particular care being taken underneath the pipe haunches to fill all voids. All concrete used for the footing, cap and bags shall have a minimum compressive strength of 21MPa in 28 days and include 6% ± 1% air entrainment. Concrete-filled jute bag headwalls shall be installed in accordance with the **"Typical Concrete Filled Jute Bag Headwall End Protection Details"** outlined herein.

## **X. SLOPED QUARRIED LIMESTONE EROSION PROTECTION FOR VERTICAL HEADWALLS**

The sloped quarried limestone erosion protection shall be embedded into the side slopes of the drain at a minimum thickness of 305mm and shall be underlain in all cases with a synthetic filter mat. The filter mat shall not only be laid along the flat portion of the erosion protection but also contoured to the exterior limits of the quarried limestone and the unprotected slope. The width and slope of the general erosion protection shall be as established in the accompanying drawing or as otherwise directed by the Drainage Superintendent and/or the Consulting Engineer during construction. In placing the erosion protection, the Contractor shall carefully tamp the quarried limestone pieces into place with the use of a shovel bucket so that the erosion protection when completed will be consistent, uniform and tightly laid. In no instance shall the quarried limestone protrude beyond the exterior contour of the unprotected drain side slopes along either side of said protection. The synthetic filter mat to be used shall be **non-woven** geotextile MacTex MX140 conforming to OPSS 1860 Class I, as available from Armtec Construction Products, or approved equal. The quarried limestone to be used shall be graded in size from a minimum of 100mm (4") to a maximum of 250mm (10"), and is available from Walker Aggregates, in Amherstburg, Ontario, or approved equal. Sloped quarried limestone erosion protection shall be installed in accordance with the "**Typical Quarried Limestone End Protection Detail**" outlined herein.

## **XI. ANCILLARY WORK**

During the course of any repair or improvements, the Contractor will be required to protect or extend any existing tile ends or swales to maintain the drainage from the adjacent lands. All existing tiles within the proposed alignment shall be extended utilizing Boss 1000 or equal plastic pipe of the same diameter as the existing tile and shall be installed in accordance with the "**Standard Lateral Tile Detail**" outlined herein unless otherwise noted. Connections shall be made using a Manufacturer's coupling wherever possible. Openings into new pipes shall be neatly saw-cut to the satisfaction of the Drainage Superintendent and/or the Consulting Engineer. For other connections, the Contractor shall utilize a grouted connection. Grouted mortar joints shall be composed of three (3) parts of clean, sharp sand to one (1) part of Portland Cement with just sufficient water added to provide a stiff plastic mix. The mortar joint shall be of sufficient mass around the full circumference of the joint on the exterior side to ensure a tight, solid seal. The Contractor is to note that any intercepted pipes along the length of the existing pipes are to be extended and diverted to the downstream end of the new pipe unless otherwise noted in the accompanying drawings.

Where the culvert installation interferes with the discharge of an existing swale, the Contractor shall re-grade the existing swales to allow for the surface flows to freely enter the drain. Any disturbed grass areas shall be fully restored with topsoil, seed and mulch. The Contractor shall also be required as part of the culvert replacement to excavate and widen the drain bottom where required to fit the new pipes in order to provide a smooth transition between the new culvert installation and the existing drain.

The Contractor, when doing their excavation or any other portion of the work, shall be very careful not to interfere with, plug up or damage, any existing surface drains, swales and lateral or main tile ends. If it is found that said existing drains are interfered with in any way, the Contractor will be required to unplug or repair said drains immediately, at no extra cost to the project. If it is found that any existing lateral tiles or main tile drains or tile ends have been cut off or damaged in any way during the course of the work, the Contractor will be required to either repair or replace same, to the satisfaction of the Drainage Superintendent and the Consulting Engineer.

The Contractor shall take steps to protect all legal survey bars during the course of its work. If any bars are removed or damaged, the Contractor shall arrange for an Ontario Land Surveyor licensed in the Province of Ontario to replace same, all at its cost.

All of the work required towards the installation and improvements to all structures shall be performed in a neat and workmanlike manner and the general site shall be restored to its' original condition, and all of same is to be performed to the satisfaction of the Drainage Superintendent and the Consulting Engineer.

## **XII. TOPSOIL, SEED AND MULCH**

During the course of its excavation operations, the Contractor will be required to salvage all available topsoil. Where necessary, this material shall be stockpiled by the Contractor in order to avoid contamination and shall be utilized in carrying out the topsoil placement along all specified newly excavated and filled or disturbed areas, in preparation for the seeding and mulching operation to be carried out as part of the restoration works. The Contractor shall be required to use the scavenged topsoil stripped from the drain banks. The balance of the topsoil required shall be obtained by the Contractor at its own expense.

The Contractor shall be required to restore all existing grassed areas and drain side slopes damaged or disturbed by the structure installation and/or removal, and place topsoil and seed and mulch over said areas including any specific areas noted on the Drawings. The Contractor shall be required to provide all the material and to cover the above-mentioned surface areas with approximately 50mm of good, clean, dry topsoil on slopes and 100mm of good, clean, dry topsoil on horizontal surfaces, fine graded and spread in place ready for seeding and mulching. The Contractor is to note that prior to fine grading the topsoil over the backfilled areas, positive drainage is to be provided off of these areas and into the swales, and the Contractor shall also be required to make minor changes where necessary to ensure same. The Contractor shall be required to restore all existing grassed areas and roadway boulevard areas damaged by the culvert work and shall provide topsoil and seed and mulch over all of these areas. The placing and grading of all topsoil shall be carefully carried out according to Ontario Provincial Standard Specifications, Form 802, dated November 2010, or as subsequently amended or as amended by these Specifications. Once the topsoil has been properly placed and fine-graded, the Contractor shall seed and mulch the area. Seeding and mulching operations shall be carried out according to Ontario Provincial Standard Specifications, Form 572, dated November 2003, or as subsequently amended or as amended by these Specifications. The seeding mixture shall be OSECO Seed Mixture Canada No. 1, as available from Morse Growers Supply in Leamington, or equal. As part of the seeding and mulching operation, the Contractor will be required to provide either a hydraulic mulch mix or a spread straw mulch with an adhesive binder in accordance with OPSS 1103.05.03 dated November 2016, or as subsequently amended, to ensure that the grass seed will be protected during germination and provide a thick, uniform cover to protect against erosion, where necessary. All work shall be completed to the satisfaction of the Drainage Superintendent or the Consulting Engineer.

All of the work relative to the placement of topsoil and the seeding and mulching operation shall be meticulously done and completed in a good and workmanlike manner all to the satisfaction of the Drainage Superintendent or Consulting Engineer.

**XIII. FINAL CLEANUP AND RESTORATION**

The whole of the work shall be satisfactorily cleaned up, and during the course of the construction, no portion shall be left in any untidy or incomplete state before subsequent portions are undertaken.

All roadways, driveways and access bridges, or any other means of access onto the job site shall be fully restored to their former condition at the Contractor's expense. Before authorizing Final Payment, the Drainage Superintendent or the Consulting Engineer shall inspect the work in order to be sure that the proper restoration has been performed. In the event that the Contractor fails to satisfactorily clean up any portion of these accesses, the Consulting Engineer shall order such cleanup to be carried out by others and the cost of same to be deducted from any monies owing to the Contractor.

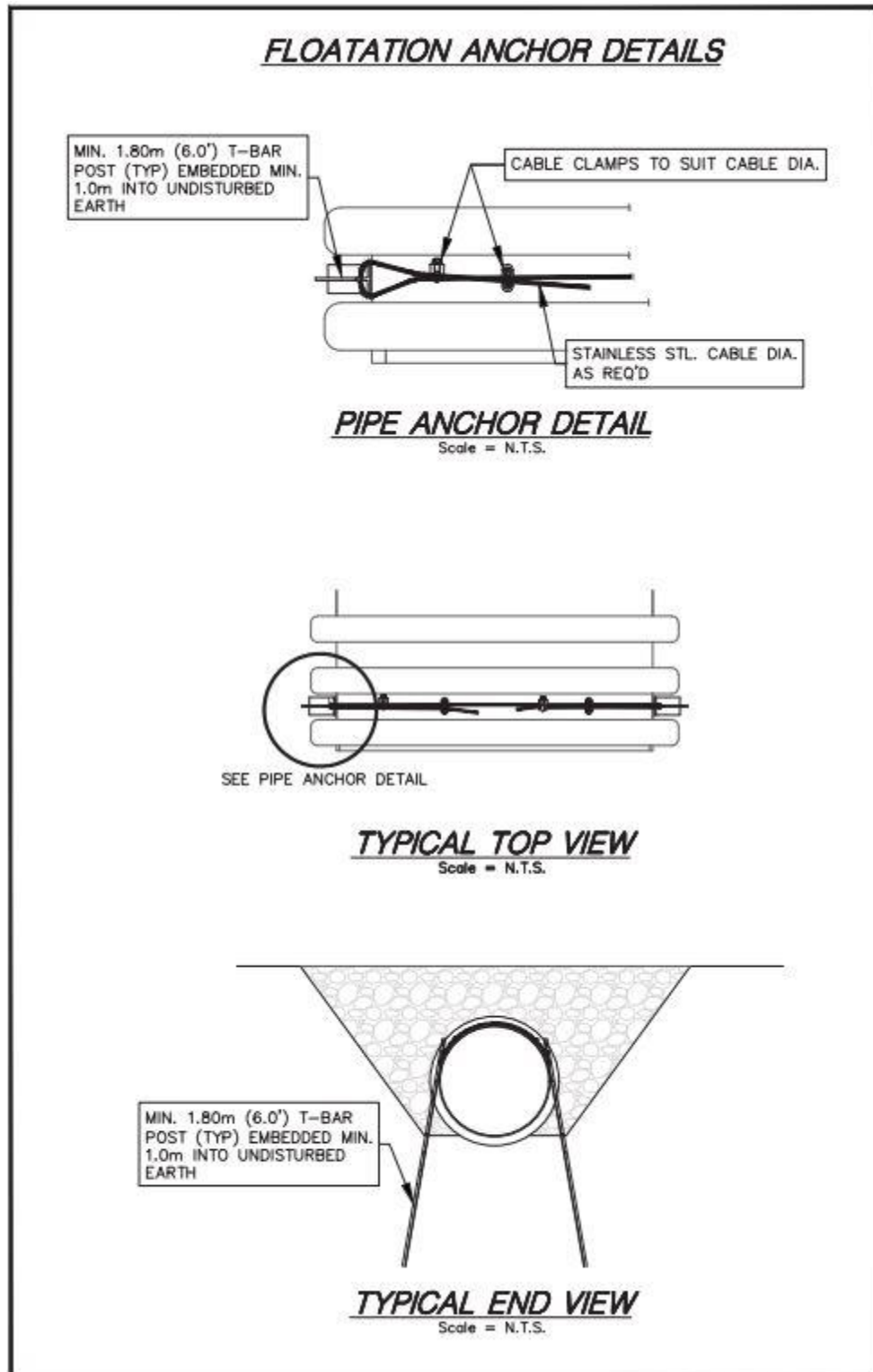

Figure 1 - Flotation Anchor Details

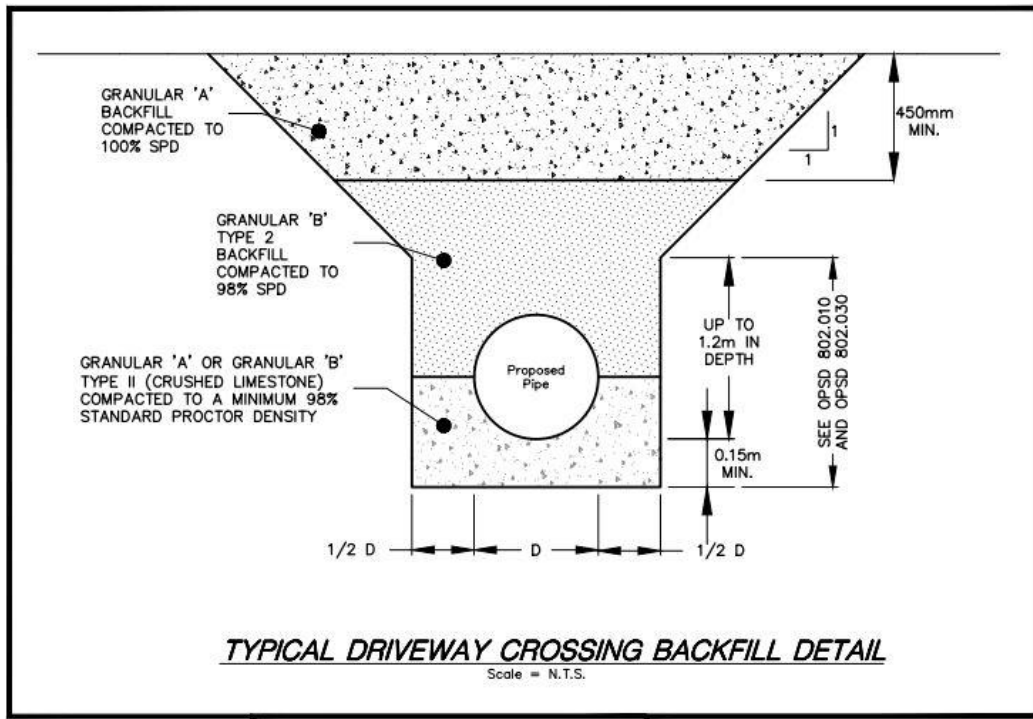

Figure 2- Typical Driveway Crossing Backfill Detail

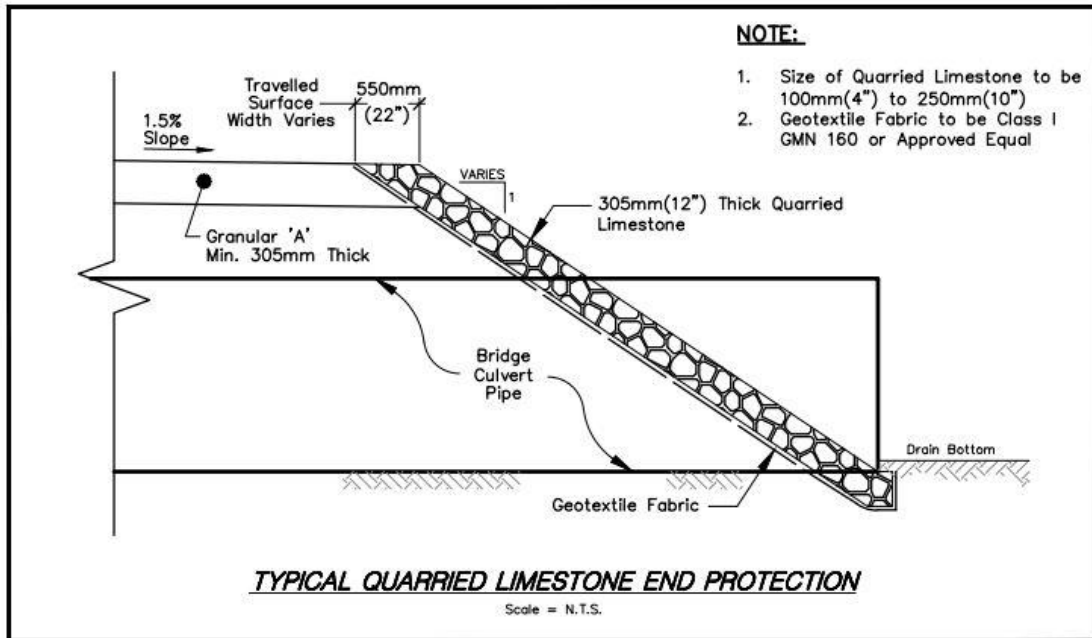

Figure 3 - Typical Quarried Limestone End Protection Detail

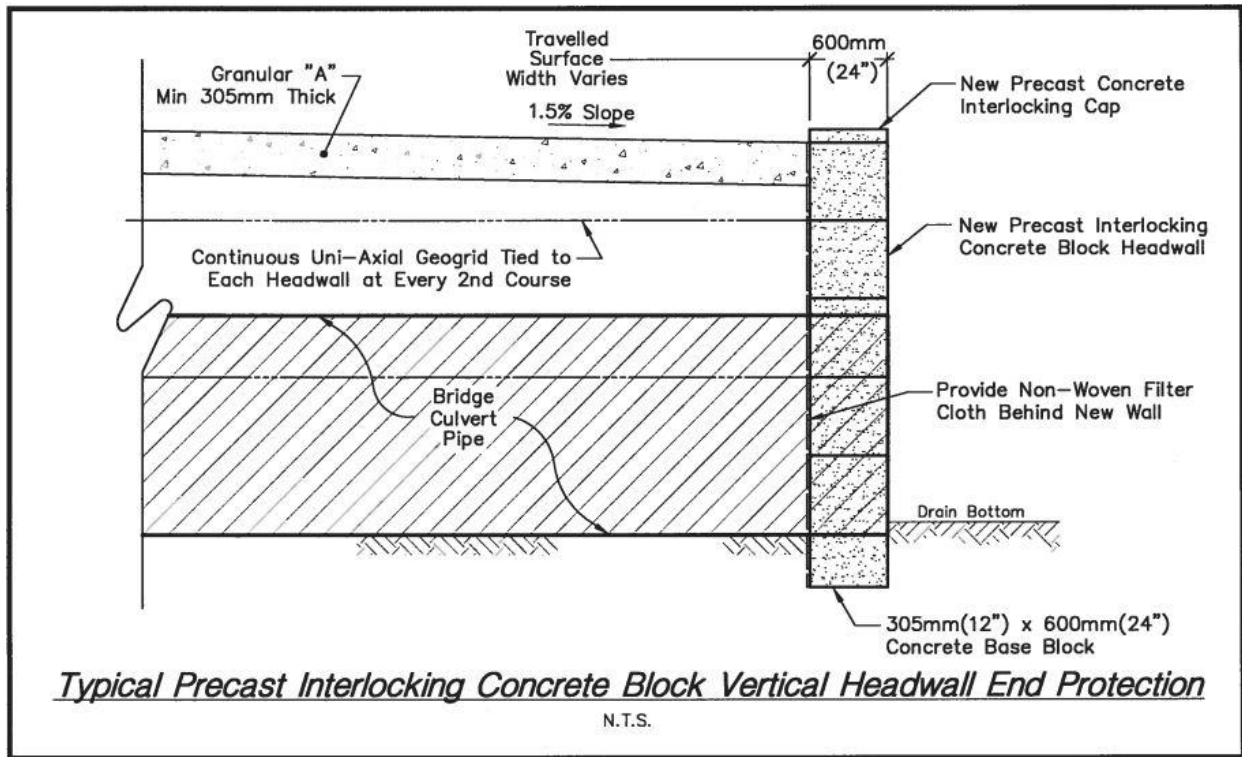

Figure 4 - Typical Precast Interlocking Concrete Block Vertical Headwall End Protection Detail

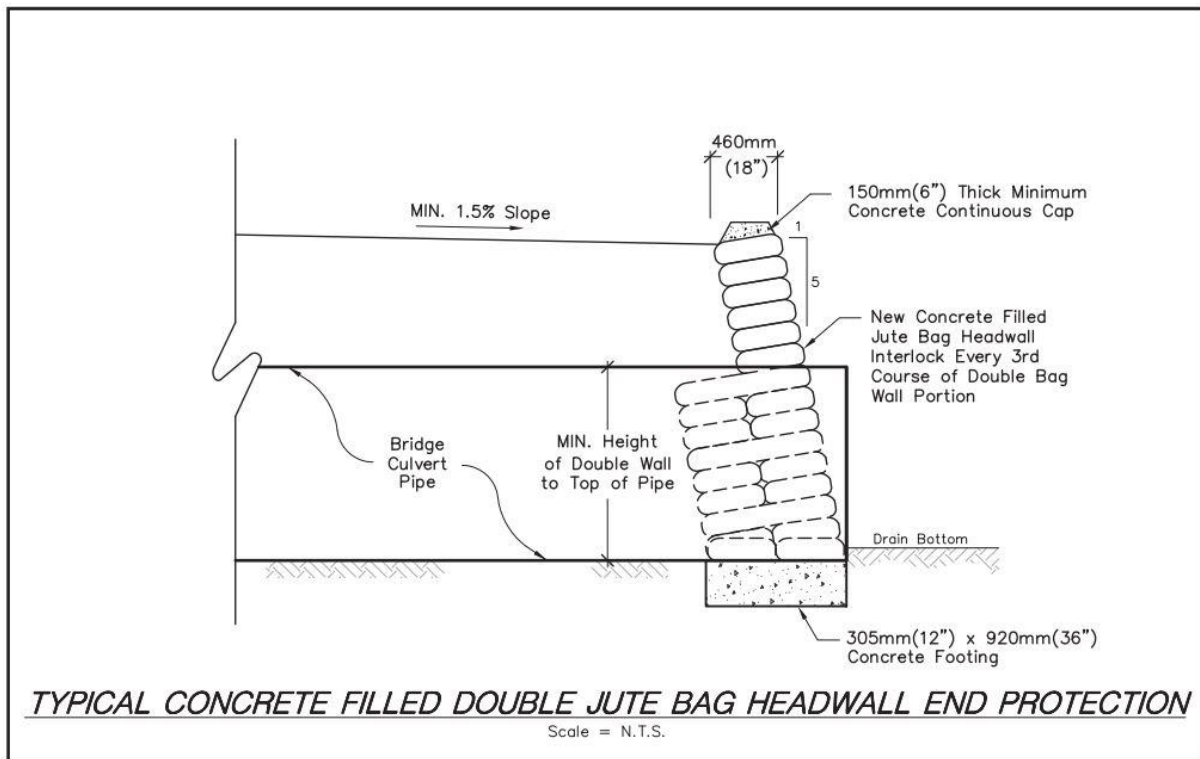

Figure 5 - Typical Concrete Filled Double Jute Bag Headwall End Protection Detail

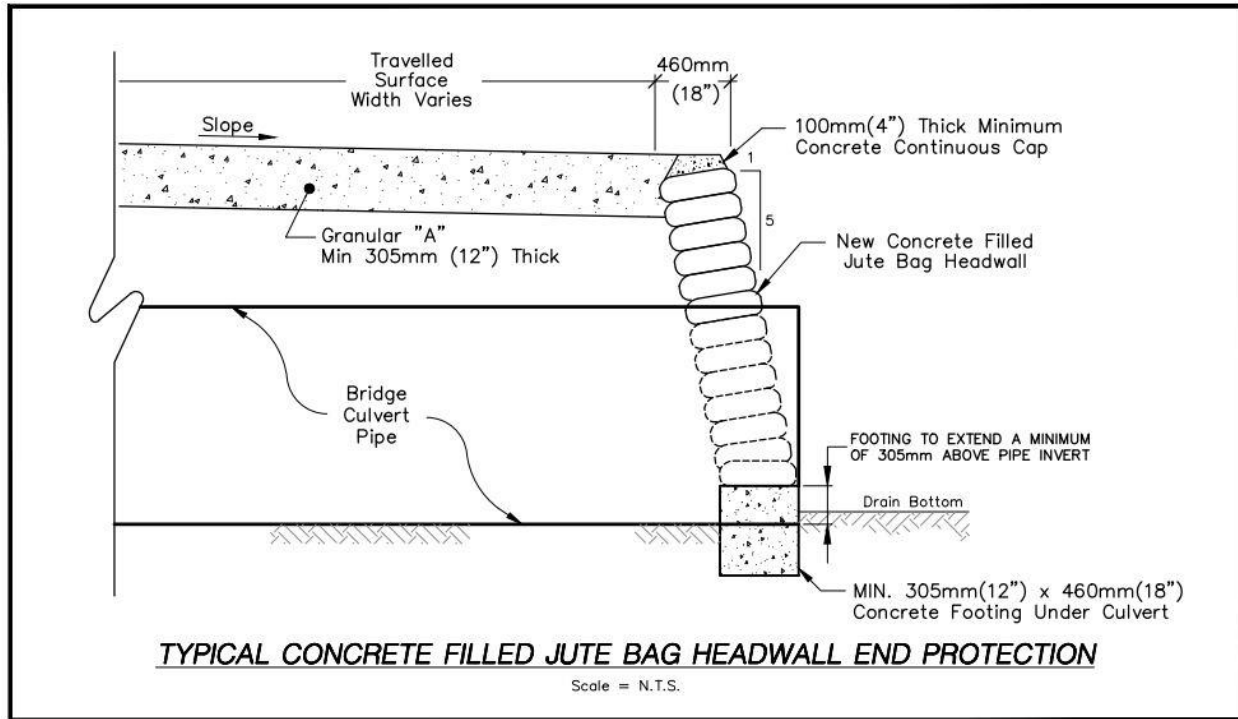

Figure 6 - Typical Concrete Filled Jute Bag Headwall End Protection Detail

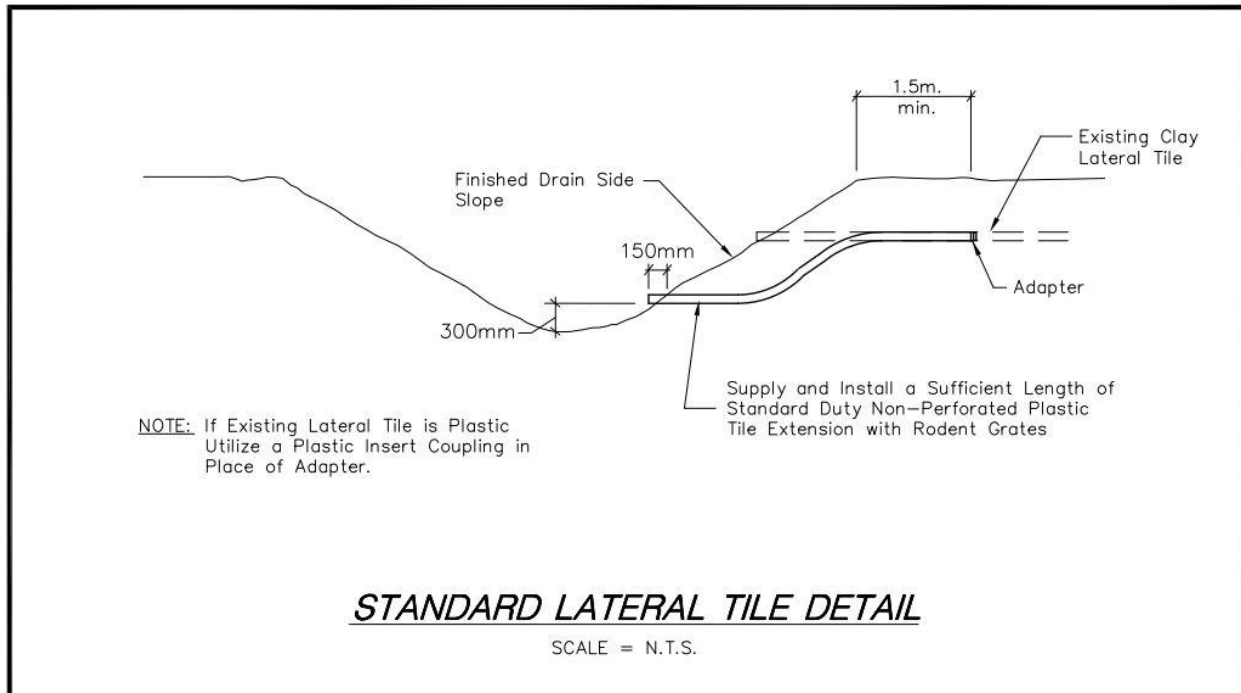

Figure 7 - Standard Lateral Tile Detail

# **SPECIAL PROVISIONS**

This page has been intentionally left blank

## TABLE OF CONTENTS

I.	General Scope of Work.....	2
II.	Conservation Authority and DFO Considerations.....	2
III.	MECP Considerations .....	3
IV.	Access to Work.....	4
V.	Details of Bridge Work .....	4
VI.	Aluminized Pipe Installation.....	5
VII.	Bridge Construction .....	6
VIII.	Sloped Quarried Limestone End Treatments .....	6

This page has been intentionally left blank

**PROJECT** | **Bridge Over the 11th Concession Road Drain  
West of Ruscom River**  
For Donald & Shannon Ames (620-02100)  
Part of Lot 19, Concession 10  
(Geographic Township of Gosfield North)  
Town of Kingsville, County of Essex  
**Project No. D25-016**

## **I. GENERAL SCOPE OF WORK**

These Special Provisions, along with the Report, Appendices, Standard Specifications and the accompanying drawings, consider the furnishings of all labour, equipment and materials required for the performance of all operations related to the installation of a new access bridge within the 11th Concession Road Drain West of Ruscom River for Donald & Shannon Ames (620-02100), in Part of Lot 19, Concession 10, within the Geographic Township of Gosfield North. The 11th Concession Road Drain West of Ruscom River is located along the south side of Road 11 and commences between Lots 16 and 17, Concession 10 and continues easterly to its outlet into the Ruscom River.

The Contractor shall provide all labour, equipment and materials to install a new access bridge consisting of 18.00 metres (59.06 ft.) of 2200mm diameter, 2.0mm thick, Aluminized Steel Corrugated Hel-Cor Pipe with annular ends and 125mm x 25mm Corrugations; sloped quarried limestone on filter cloth end protection, granular bedding and backfill, granular approaches and transitions, excavation, compaction, topsoil, seeding and mulching, cleanup and restoration, complete.

All work shall be carried out in accordance with these Special Provisions and Standard Specifications that serve to supplement and/or amend the current Ontario Provincial Standard Specifications and Standard Drawings, adopted by the Ontario Municipal Engineers Association. The Contractor shall review the information outlined within **Appendix "A"**. The works shall be further carried out in accordance with these Special Provisions and Specifications and shall comply in all regards with the accompanying drawings labelled herein as **Appendix "B"**. The new access bridge shall be of the size, type, depth, etc., as is shown in the accompanying drawings, as determined from the **Benchmark**, and as may be further laid out at the site at the time of construction. All work carried out under this project shall be completed to the satisfaction of the Drainage Superintendent or the Consulting Engineer.

## **II. CONSERVATION AUTHORITY AND DFO CONSIDERATIONS**

The Contractor shall be required to implement stringent erosion and sedimentation controls during the course of the work to minimize the amount of silt and sediment being carried downstream. It is intended that work on this project be carried out during relatively dry weather to ensure the proper site and drain conditions and to avoid conflicts with sediment being deposited into the outlet drainage systems. All disturbed areas shall be restored as quickly as possible with grass seeding and mulching installed to ensure a protective cover and to minimize any erosion from the work site subsequent to construction. The

Contractor may be required to provide temporary silt fencing and straw bales as outlined further in these specifications.

All of the work shall be carried out in accordance with any permits or authorizations issued by the Conservation Authority or the Department of Fisheries and Oceans (DFO), copies of which shall be provided, if available. The Contractor is advised that no work shall be carried out in the existing drain from March 15 to July 15, of any given year.

As part of its work, the Contractor shall implement the following measures that shall ensure that any potential adverse effects on fish and fish habitat shall be mitigated:

- a) As per standard requirements, work shall not be conducted at times when flows in the drain are elevated due to local rain events, storms, or seasonal floods. Work shall be done in the dry.
- b) All disturbed soils on the drain banks and within the channel, including spoil, must be stabilized immediately upon completion of work. The restoration of the site must be completed to a like or better condition than what existed prior to the works. The spoil material must be hauled away and disposed of at a suitable site or spread an appropriate distance from the top of the drain bank to ensure that it is not washed back into the drain.
- c) To prevent sediment entry into the Drain, in the event of an unexpected rainfall, silt barriers and/or traps must be placed in the channel during the works and until the site has been stabilized. All sediment and erosion control measures are to be in accordance with related Ontario Provincial Standards. It is incumbent on the proponent and its contractors to ensure that sediment and erosion control measures are functioning properly and are maintained/upgraded as required.
- d) Silt or sand accumulated in the barrier traps must be removed and stabilized on land once the site is stabilized.
- e) All activities, including maintenance procedures, should be controlled to prevent the entry of petroleum products, debris, rubble, concrete, or other deleterious substances into the water. Vehicular refuelling and maintenance should be conducted away from the water.

Not only shall the Contractor comply with all of the above, but it shall also be required to further comply with any mitigation measures included within the email correspondence with the Conservation Authority. Furthermore, the Contractor shall also review and comply with the "Best Management Practices – Culvert Replacements in Municipal Drains" document prepared by the DFO, included within **Appendix "A"**

### **III. MECP CONSIDERATIONS**

Under the Species at Risk Provincial Legislation, set in place with the Ministry of Environment, Conservation and Parks (MECP), Section 23.9 of the Endangered Species Act, 2007, allows the Municipality to conduct eligible repair, maintenance, and improvement work under the Drainage Act that exempts these works from Sections 9 and 10 of this Act, so long as they follow the rules within Ontario Regulation 242/08.

Prior to commencing work, the Municipality will complete an “Endangered Species Act Review” for the subject drain and will provide the Contractor with the results of said review, including documents for the purpose of identification of known Species at Risk within the project area and mitigation measures for species and habitat protection. It is the responsibility of the Contractor to make certain that necessary provisions are undertaken to ensure the protection of all Species at Risk and their habitats throughout the course of construction.

The Contractor will be responsible for providing the necessary equipment and materials required by the mitigation plans and shall contact the Drainage Superintendent immediately if any Endangered Species are encountered during construction.

#### **IV. ACCESS TO WORK**

The Contractor is advised that the majority of the work to be carried out on this project extends along the south side of Road 11. The Contractor shall have access to the full length of the roadway abutting the proposed drainage works. The Contractor may use the entire width of the right-of-way as necessary to permit the completion of the work required to be carried out for this project. Furthermore, in order to perform the necessary work identified within this project, the Contractor shall have access to the subject private lands south of the Road 11 right-of-way limit for a distance of 8.00 metres, necessary to perform the new access bridge installation. Under no circumstances shall the Contractor utilize other private lands.

#### **V. DETAILS OF BRIDGE WORK**

The Contractor shall provide all labour, equipment, and materials to install a new access bridge for the agricultural lands of Donald & Shannon Ames (620-02100), within the 11th Concession Road Drain West of Ruscom River, according to the Drawings, the Schedule of Items, and in these Specifications stated below. The Drainage Superintendent and/or the Consulting Engineer shall have the authority to carry out minor changes to the work where such changes do not lessen the efficiency of the work.

<b>Pipe Specifications</b>	
Culvert Type:	Aluminized Steel Corrugated Hel-Cor Pipe
Pipe Length:	18.00m (59.06 ft.)
Pipe Diameter:	2200mm
Pipe Gauge/Stiffness:	2.0mm (14 Ga.)
Corrugation:	125mm x 25mm (5.0" x 1.0")
Pipe Grade:	0.06%
Min. Depth of Cover:	400mm (15.75 in.)
Upstream Invert Elev. (East)	187.556m

Pipe Specifications	
Downstream Invert Elev. (West)	187.545m
Embedment:	240mm (11.0%)

Drain Specifications	
Flow Direction:	West to East
Drain Grade:	0.06%
Bottom Width:	0.914m (3.0 ft.)
Drain Bottom Relative to Design Grade:	At Design Grade
Side Slopes:	1.5 Horizontal to 1.0 Vertical
Driveway Crossfall Grade	1.00%
Access Width (Travelled Driveway):	9.10m (30.00 ft.)
℄ of Driveway Elev. at Gravel Roadway Edge:	190.478m
℄ of Driveway Elev. at Pipe Centreline	190.253m
℄ of Driveway Elev. 9.60m South of Roadway Edge	190.055m

The new pipe for this installation is to be provided with a minimum depth of cover measured from the top surface of the driveway to the top of the pipe, as outlined above. If the bridge culvert is placed at its proper elevation, sufficient cover should be achieved. If the Contractor finds that the minimum cover is not being met, they shall notify the Drainage Superintendent and the Consulting Engineer immediately so that steps can be taken to rectify the condition prior to the placement of any backfill. The minimum cover requirement is **critical** and must be attained. In order for these new access bridge culverts to properly fit the channel parameters, **all of the design grade elevations must be strictly adhered to.**

As a check, all of the access bridge culvert design grade elevations shall be confirmed before commencing to the next stage of the access bridge installation. The Contractor is also to check that the pipe invert grades are correct by referencing the Benchmark and the information provided on the detail within the plans.

## **VI. ALUMINIZED PIPE INSTALLATION**

As outlined within the accompanying Drawings and the Construction Items, the new access bridge culvert shall consist of aluminized steel pipe materials. The new Aluminized Steel Corrugated Hel-Cor Pipe to be installed for this bridge is required to **be provided with a maximum of three (3) lengths of pipe**, coupled together with Aluminized Steel Type II 10C bolted couplers of the same thickness as the culvert pipe and secured in accordance with the Manufacturer’s recommendations. Under no circumstances shall the access

bridge culvert be provided with more than three (3) lengths of pipe. The Aluminized Steel Corrugated pipe for this installation must be of the length, size, and thickness as identified in the plans and approved by the Drainage Superintendent and/or the Consulting Engineer prior to its placement in the drain. Furthermore, the installation of aluminized steel culvert pipe shall be further installed per the provisions established within the attached Standard Specifications.

## **VII. BRIDGE CONSTRUCTION**

Once the new pipe has been satisfactorily set in place, the Contractor may commence with the backfilling operations per the Standard Specifications. As part of the culvert installation works, the Contractor shall also perform the necessary excavation to extend the width of the driveway from the existing edge of the gravel shoulder to approximately 9.60m from the gravel roadway edge. This driveway approach for the entire length and width shall consist of a minimum of 300mm (12") of granular material MTO Granular "A" satisfactory compacted in place. The gravel apron shall extend for the full width of the driveway portion of the access bridge and extend to the edge of the pavement, with a minimum of 5.0m turning radii.

Although it is anticipated that the culvert installation shall be undertaken in the dry, the Contractor shall supply and install a temporary Straw Bale Check Dam in the drain bottom immediately downstream of the culvert site during the time of construction. The straw bale check dam shall be to the satisfaction of the Drainage Superintendent and/or Consulting Engineer and must be removed upon completion of the Construction. All costs associated with the supply and installation of this Straw Bale Check Dam shall be included in the cost bid for the bridge installation.

## **VIII. SLOPED QUARRIED LIMESTONE END TREATMENTS**

As outlined within the accompanying Drawings and the Construction Items, sloped quarried limestone end treatments shall be utilized for this application. The quarried limestone end treatment shall be installed per the provisions established within the attached Standard Specifications.

This page has been intentionally left blank

# APPENDIX "A"

This page has been intentionally left blank

## **APPENDIX A-1**

### Essex Region Conservation Authority Correspondence

This page has been intentionally left blank

## Kiara Kirkland

---

**From:** Ashley Gyori <AGyori@erca.org>  
**Sent:** September 23, 2025 11:36 AM  
**To:** Subhi Al-Dallal  
**Cc:** Lu-Ann Marentette; Clare Janisse; Tony Peralta; Kiara Kirkland  
**Subject:** RE: Section 78 Request for new Access - 11th Conc Drain - West of Ruscom River (D25-016)  
**Attachments:** 20250922 - PRELIMINARY - Bridge Over the 11th Concession Road Drain West of Ruscom River (D25-016).pdf; 1976-06-18 RECONSID. REPORT 11th Concession Road Drain West of Ruscom River - W Settingington.pdf; 1976-06-18 RECONSID. PLAN & PROFILE 11th Concession Road Drain West of Ruscom River - W.Setterington.pdf

Good morning Subhi,

Thank you for providing the attached Preliminary Drawings for the new access over the above noted drain, Project No. D25-016. I've had an opportunity to review the preliminary drawings and the available information and can confirm that our office is supportive of this proposal, as presented in the preliminary stages.

We look forward to receiving the Final Drainage Report and Drawings. A completed Application for Permit form will be required from the municipality.

If you have any questions, please do not hesitate to contact this office.

Kind regards,



ASHLEY GYORI  
Regulations Analyst  
Essex Region Conservation Authority  
360 Fairview Avenue West, Suite 311 • Essex, Ontario • N8M 1Y6  
[agyori@erca.org](mailto:agyori@erca.org) • [essexregionconservation.ca](http://essexregionconservation.ca)

**Please consider the environment before printing this email**

*This e-mail transmission is confidential and may contain proprietary information for the express use of the intended recipient. Any use, distribution or copying of this transmission, other than by the intended recipient, is strictly prohibited. If you are not the intended recipient, please notify us by telephone at the number above and arrange to return this transmission to us or destroy it.*

**Follow us on Twitter:** [@essexregionca](https://twitter.com/essexregionca)

**VACATION ALERT: I WILL BE AWAY FROM THE OFFICE FROM SEPTEMBER 25<sup>TH</sup>, 2025, UNTIL OCTOBER 6<sup>TH</sup>, 2025.**

The ERCA Office is open to the public **Tuesdays, Wednesdays and Thursdays** to provide “counter service”; however, services continue to be delivered online and through email. Please consult ERCA’s website for more information and direction regarding online services (i.e. permitting, cottage bookings, seasonal passes etc.).

---

**From:** Subhi Al-Dallal <s.al-dallal@peraltaengineering.com>  
**Sent:** September 22, 2025 2:53 PM  
**To:** Ashley Gyori <AGyori@erca.org>; Drainage <drainage@ERCA.org>  
**Cc:** Lu-Ann Marentette <lmarentette@kingsville.ca>; Clare Janisse <cjanisse@kingsville.ca>; Tony Peralta

<tony@peraltaengineering.com>; Kiara Kirkland <kiara@peraltaengineering.com>

**Subject:** RE: Section 78 Request for new Access - 11th Conc Drain - West of Ruscom River (D25-016)

Good afternoon Ashley,

Further to the correspondence outlined below, our office was appointed under Section 78 of the Drainage Act for the installation of a new access bridge over the 11<sup>th</sup> Concession Road Drain West of Ruscom River for Donald & Shannon Ames (620-02100) along the south side of Kingsville Road 11. Per our discussions with Municipal Staff and the owner of the parcel, this new access is a requirement of a consent application to sever the retained agricultural lands.

We wish to provide you with the preliminary design proposal for the above-noted project. Based on our preliminary design, we have determined the following details:

The new access shall be installed on the east half of the newly severed farm portion of the property. Approximately 40 metres upstream of the proposed access bridge location is an existing 2,750mm x 3,000mm concrete span bridge, having a total length of 5.0 metres. Approximately 440 metres further upstream of the proposed access bridge location is an existing road crossing with a 2,400 mm diameter CSP culvert with jute bag headwall end treatments having a total length of 21.4 metres. Approximately 112 metres downstream of the proposed access bridge location is an existing 2,600mm x 1,900mm CSP arch culvert (equivalent diameter = 2,300mm) having a total length of 7.7 metres with masonry block end treatments.

We have determined that the new access bridge shall consist of approximately 18.0 metres of 2200mm diameter CSP pipe, with sloped quarried limestone end treatments and 240mm of pipe embedment. This access bridge is intended to provide a top width of 9.10m (30.0') with a minimum 5.0m turning radius from approximately the edge of the asphalt roadway. This access bridge has been designed to have the capacity to handle the 5-year return storm event. Attached, please find preliminary design drawings for your review.

To assist with your review, attached you will also find the 1976 governing report and plans for the 11<sup>th</sup> Concession Road Drain West of Ruscom River.

We have reviewed the DFO website as it relates to the Fisheries Act and have performed a "Self Assessment" for this project. Also, as it relates to the Endangered Species Act, we have contacted the Town of Kingsville to ensure that this project is covered under the new ESA Regulation 242/08.

We trust that this information is satisfactory. However, if you have any concerns or require additional information, please do not hesitate to contact us.

Best Regards,



**Subhi Al-Dallal**, Drainage Engineer In-Training  
[s.al-dallal@peraltaengineering.com](mailto:s.al-dallal@peraltaengineering.com) | 519-733-6587 x 142  
N.J. Peralta Engineering Ltd. - Consulting Engineers  
45 Division St. N., Kingsville ON N9Y 1E1  
[peraltaengineering.com](http://peraltaengineering.com)



The content of this email is the confidential property of N.J. Peralta Engineering Ltd. and should not be copied, modified, retransmitted, or used for any purpose except with Peralta Engineering's written authorization. If you are not the intended recipient, please delete all copies and notify us immediately.

---

**From:** Ashley Gyori <[AGyori@erca.org](mailto:AGyori@erca.org)>  
**Sent:** Wednesday, February 26, 2025 9:26:07 AM  
**To:** Lu-Ann Marentette <[lmarentette@kingsville.ca](mailto:lmarentette@kingsville.ca)>  
**Subject:** RE: Section 78 Request for new Access - 11th Conc Drain - West of Ruscom River

CAUTION: This email originated from outside your organization. Exercise caution when opening attachments or clicking links, especially from unknown senders.

Good morning Lu-Ann,

Thank you for sending the Notice of Request for the new access bridge over the 11<sup>th</sup> Conc. Drain West of Ruscom River.

A review of our floodplain mapping for the 11<sup>th</sup> Conc. Drain West of Ruscom River indicates that this drain is located within an area that is under the jurisdiction of the Essex Region Conservation Authority (ERCA) (Section 28 of the *Conservation Authorities Act*). Prior to undertaking works, a permit is required from this office.

A review of the available information shows that there is an existing concrete bridge structure in the vicinity of the proposed works. Many of these large concrete structures were not sized for any particular rainfall event or flowrate, and therefore, it is not necessarily a requirement to install an equivalent level-of-service pipe adjacent to the concrete clear span structure. However, it is expected that any proposed bridge structure be sized to meet the applicable level of service of the drain, and that the engineer demonstrate and/or justify that there are no adverse flood impacts caused by the new structure. The Guide for Engineers Working Under the Drainage Act in Ontario (Publication 852) provides guidance on level of service, along with municipal-specific and Conservation Authority related design standards. Note that locally, ERCA regulates the 1:100 return period event and, when it is warranted, due consideration for the impacts related to this event may need to be considered by the practitioner. We cannot be more specific in this regard without an actual proposal to review. Prior to the engineer moving forward with the final report, we kindly request that they provide this office with the opportunity to review the preliminary design so that any additional or outstanding ERCA comments can be addressed prior to the meeting of consideration.

It should also be noted that ERCA does not review proposals on behalf of other agencies (i.e. Department of Fisheries and Oceans, Ministry of the Environment, Conservation and Parks, Ministry of Natural Resources and Forestry, etc.). It is the proponent's responsibility to ensure that all applicable authorizations have been obtained.

If further information or clarification is required, please do not hesitate to contact this office.

Kind regards,



ASHLEY GYORI  
Regulations Analyst  
Essex Region Conservation Authority  
360 Fairview Avenue West, Suite 311 • Essex, Ontario • N8M 1Y6  
[agyori@erca.org](mailto:agyori@erca.org) • [essexregionconservation.ca](http://essexregionconservation.ca)

**Please consider the environment before printing this email**

*This e-mail transmission is confidential and may contain proprietary information for the express use of the intended recipient. Any use, distribution or copying of this transmission, other than by the intended recipient, is strictly prohibited. If you are not the intended recipient, please notify us by telephone at the number above and arrange to return this transmission to us or destroy it.*

**Follow us on Twitter: @essexregionca**

The ERCA Office is open to the public **Tuesdays, Wednesdays and Thursdays** to provide “counter service”; however, services continue to be delivered online and through email. Please consult ERCA’s website for more information and direction regarding online services (i.e. permitting, cottage bookings, seasonal passes etc.).

---

**From:** Lu-Ann Marentette <[lmarentette@kingsville.ca](mailto:lmarentette@kingsville.ca)>  
**Sent:** February 24, 2025 11:06 AM  
**To:** Ashley Gyori <[AGyori@erca.org](mailto:AGyori@erca.org)>  
**Subject:** Section 78 Request for new Access - 11th Conc Drain - West of Ruscom River

Hi Ashley

The owner of 516 Road 11 is requesting to sever off the house from the farmlands and therefore requests a new access for the farmlands. We are going to appoint Peralta Engineering to design the works.

As per Section 78(2) -please accept this as notice.

**Notice**

- (2) An engineer shall not be appointed under subsection (1) until 30 days after a notice has been sent to the following persons advising them of the municipality’s intent to undertake the major improvement project:
1. The secretary-treasurer of each conservation authority that has jurisdiction over any lands that would be affected by the project.
  2. The prescribed persons. 2020, c. 18, Sched. 4, s. 9 (5).



Thank you



**Lu-Ann Marentette**  
Drainage Superintendent  
The Corporation of the Town of Kingsville  
2021 Division Road North  
Kingsville, Ontario N9Y 2Y9  
Phone: (519) 733-2305  
Web: [www.kingsville.ca](http://www.kingsville.ca)

This email message is for the sole use of the intended recipient and may not be copied.  
If you are not the intended recipient, please destroy all copies of this email and notify the sender immediately.



Please consider the environment before printing this email.

This page has been intentionally left blank

## **APPENDIX A-2**

### DFO Best Management Practices

This page has been intentionally left blank

## Best Management Practices – Culvert Replacements in Municipal Drains

This document describes the conditions on which one may proceed with a culvert replacement in a municipal drain without DFO approval/notification. All municipal, provincial, or federal legislation that applies to the work being proposed must be respected. If the conditions/requirements below cannot be met, please complete the drain notification form and submit it to the Fisheries Protection Program form review at: [FisheriesProtection@dfo-mpo.gc.ca](mailto:FisheriesProtection@dfo-mpo.gc.ca).

### Potential Impacts to Fish Habitat

- Infilling fish habitat by encroachment of the water crossing footprint or channel realignment to accommodate culvert
- Harmful substrate alteration of fish habitat (e.g. blockage of groundwater upwellings, critical SAR habitat, spawning areas)
- Removal of riparian vegetation and cover along the banks of the municipal drain
- Removal of edge habitat (e.g. undercut bank, shallower areas with lower velocity, aquatic vegetation) creation of barriers to fish movement (e.g. perched crossings, velocity barriers, alteration of the natural stream gradient)
- Alteration of channel flow velocity and/or depth (e.g. oversized culvert resulting in insufficient depth for fish passage at low flow or undersized culvert resulting in a flow velocity barrier at high flow)
- Alteration of channel morphology and sediment transport processes caused by the physical structure of the crossing resulting in upstream and downstream sediment aggradation/erosion
- Re-entry of sediment that was removed/stockpiled into the watercourse
- Erosion downstream from sudden release of water due to the failure of site isolation
- Stranding of fish in isolated ponds following de-watering of the site
- Impingement or entrainment of fish when de-watering pumps are used
- Short term or chronic transport of deleterious substances, including sediment, into fish habitat from construction or road drainage

### Requirements

The following requirements must be met:

- There are no aquatic Species at Risk present in the work zone or impact zone. To confirm there are no aquatic Species at Risk present, refer to the document, [A Guide for Interpreting Fish and Mussel Species at Risk Maps in Ontario](http://www.dfo-mpo.gc.ca/Library/356763.pdf) which can be found at: <http://www.dfo-mpo.gc.ca/Library/356763.pdf>. Links for Ontario Conservation Area specific fish and mussel maps that include critical habitat extents and a list of aquatic Species at Risk found within the conversation authority boundary can be found on Page 5 of [A Guide for Interpreting Fish and Mussel Species at Risk Maps in Ontario](http://www.dfo-mpo.gc.ca/Library/356763.pdf).
- The culvert is embedded into the streambed and must allow for the free passage of fish.
- The work involves like-for-like replacements of existing road or private access culverts on all drain types without SAR.
- On C and F Drains only, this can also include replacements with extensions and end walls for the purposes of providing the property or road with safe access, but the project permanent footprint will not increase more than 250 m<sup>2</sup> below the high water mark.
- The project does not involve replacing a bridge or arch with one or more culverts installed in parallel or a larger-diameter culvert with more than one culvert installed in parallel.

- The project does not involve building more than one culvert installed in parallel on a single watercourse crossing site (e.g. twin culvert).
- The project does not involve temporarily narrowing the watercourse to an extent or for a duration that is likely to cause erosion, structural instability or fish passage problems.
- The municipal drain has no flow/low flow or is frozen to the bottom at the time of the replacement.
- In-water work is scheduled to respect timing windows (Tables 1 and 2) to protect fish, including their eggs, juveniles, spawning adults, and/or the organisms upon which they feed.
- The work can be conducted using the Culvert Removal Method described below and Standard Measures to Avoid Causing *Serious Harm to Fish* will be implemented when required.

Note: If your project must be conducted without delay in response to an emergency (e.g. the project is required to address an emergency that poses a risk to public health or safety or to the environment or property), you may apply for an Emergency Authorization (<http://www.dfo-mpo.gc.ca/asp/forceDownload.asp?FilePath=/pnw-ppe/reviews-revues/Emergency-Authorizations-Autorisations-Urgences-eng.pdf>).

### **Culvert Removal Methodology**

- Plan/manage the work site in a manner that prevents sediment from entering the municipal drain by installing sediment and erosion control materials where required. Ensure that a sediment and erosion control plan is developed and modified as necessary for the site.
- Where required, install effective erosion and sediment control measures before starting work to prevent sediment from entering the municipal drain.
- Implement site isolation measures when in-water work is required.
  - Install an impervious barrier upstream of the work area (Figure 1). If possible, install a secondary barrier upstream of the work area for added protection.
  - Attempt to drive out the fish from the work area and then install the impervious barrier downstream of the work area. This may reduce or eliminate the need for a fish salvage.
  - When the drain is flowing, maintain downstream flows (e.g. bypass water around the work site using pumps or flume pipes; Figure 2). Provide temporary energy dissipation measures (e.g. rip-rap) at discharge point of the hose or temporary outlet pipe when required. Routinely inspect bypass pump and hose or pipe to ensure proper operation. Inspect discharge point for erosion and reposition hose/pipe or install additional temporary energy dissipation material as needed.
  - Dewater the isolated work area. The hose for a pump may discharge along the top of the bank into existing vegetation; however, the area should be monitored for signs of erosion. Reposition the hose or install additional temporary energy dissipation material as needed.
  - A fish screen with openings no larger than 2.54 mm (0.10 inches) should be equipped on any pump used during the operation. Note: Additional information regarding fish screens can be found in the DFO Freshwater Intake End-of-Pipe Fish Screen Guideline document (<http://www.dfo-mpo.gc.ca/Library/223669.pdf>).
  - Collect any fish present in the isolated work area and relocate them downstream.
  - Fish salvage operations must be conducted under a license issued by the Ontario Ministry of Natural Resources and Forestry (MNRF). The MNRF should be contacted well in advance of any work to obtain the required fish collection license.
- Install the culvert so that it is embedded into the streambed; ensure the culvert remains passable (e.g. does not become perched) by fish and wildlife.

- Decommission the site isolation in a manner that minimizes the introduction of sediment. The downstream isolation barrier shall gradually be removed first, to equalize water levels inside and outside of the isolated area and to allow suspended sediments to settle.
- Stabilize and remove waste from the site.
- Where required, maintain effective erosion and sediment control measures until complete re-vegetation of disturbed areas is achieved.



**Figure 2. Isolation of Site**

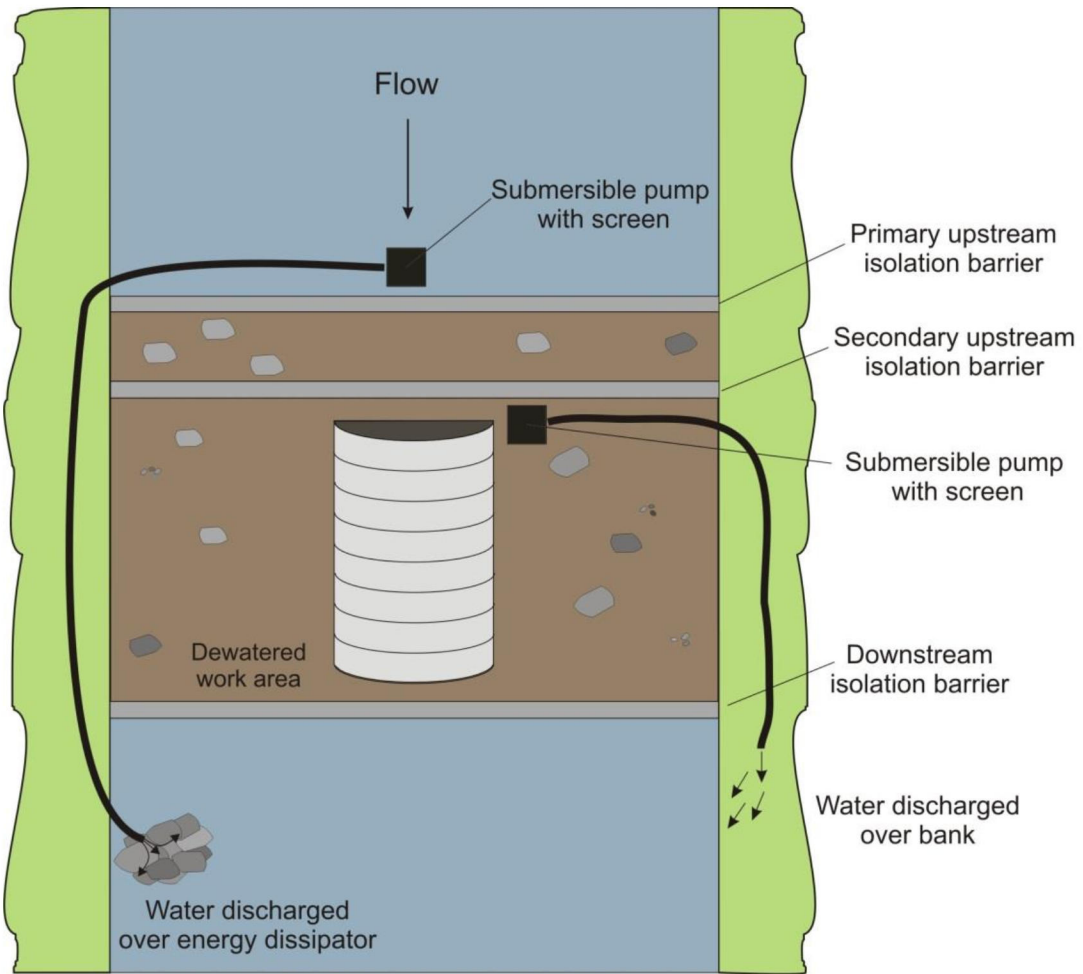

**Figure 3. Isolation and Bypass Diversion when Working In-Water**

## Timing Windows

Figure 1 and Tables 1 and 2 can be used to determine the Restricted Activity period for the drain based on its classification. Note: Timing windows identified on [Conservation Authority](#) permits or [Ministry of Natural Resources](#) (Government of Ontario) work permits may differ and take precedence.



**Figure 1. Ontario's Northern and Southern Region boundaries for determining application of restricted activity timing windows.**

**Table 1. Restricted Activity timing windows for the protection of spawning fish and developing eggs and fry in the Northern Region. Dates represent when work should be avoided.**

DRAIN TYPE	RESTRICTED ACTIVITY PERIOD
A	SEPTEMBER 1 TO JULY 15
B	SEPTEMBER 1 TO JULY 15
C	APRIL 1 TO JULY 15
D	SEPTEMBER 1 TO JULY 15
E	APRIL 1 TO JULY 15

**Table 2. Restricted Activity timing windows for the protection of spawning fish and developing eggs and fry in the Southern Region. Dates represent when work should be avoided.**

DRAIN TYPE	RESTRICTED ACTIVITY PERIOD
A	SEPTEMBER 15 TO JULY 15
B	MARCH 15 TO JULY 15
C	MARCH 15 TO JULY 15
D	OCTOBER 1 TO JULY 15
E	MARCH 15 TO JULY 15

### Standard Measures to Avoid Causing *Serious Harm to Fish*

When implementing a culvert removal project in a municipal drain, the *Fisheries Act* still requires an individual/company to ensure they avoid causing *serious harm to fish* during any activities in or near water. The following advice will help one avoid causing harm and comply with the *Act* (for additional information see <http://www.dfo-mpo.gc.ca/pnw-ppe/measures-mesures/measures-mesures-eng.html>).

1. Schedule work to avoid wet, windy and rainy periods that may increase erosion and sedimentation.
2. Whenever possible, operate machinery on land above the high water mark or on ice and in a manner that minimizes disturbance to the banks and bed of the municipal drain.
  - Ensure that machinery arrives on site in a clean condition and is maintained free of fluid leaks.
  - Limit machinery fording of the municipal drain to a one-time event (i.e., over and back), and only if no alternative crossing method is available. If repeated crossings of the municipal drain are required, construct a temporary crossing structure.
  - Wash, refuel and service machinery and store fuel and other materials for the machinery in such a way as to prevent any deleterious substances from entering the water.
  - Keep an emergency spill kit on site in case of fluid leaks or spills from machinery.
3. Install effective sediment and erosion control measures before starting work to prevent sediment from entering the municipal drain. Inspect them regularly during the course of construction and make all necessary repairs if any damage occurs.
4. Erosion and sediment control measures should be maintained until all disturbed ground has been permanently stabilized, suspended sediment has resettled to the bed of the municipal drain and runoff water is clear.
5. Undertake all in-water activities in isolation of open or flowing water while maintaining the natural flow of water downstream and avoid introducing sediment into the municipal drain.
6. Ensure applicable permits for relocating fish are obtained and relocate any fish that become trapped in isolated pools or stranded in newly flooded areas to the main channel of the watercourse.
7. Ensure that the water that is being pumped/diverted from the site is filtered (sediment remove) prior to being released (e.g. pumping/diversion of water to a vegetated area).
8. Implement measures for containing and stabilizing waste material (e.g. dredging spoils, construction waste and materials, commercial logging waste, uprooted or cut aquatic plants, accumulated debris) above the high water mark of nearby waterbodies to prevent re-entry.
9. Stabilize shoreline or banks disturbed by any activity associated with the project to prevent erosion and/or sedimentation, preferably through re-vegetation with native species suitable for the site.
10. If replacement rock reinforcement/armouring is required to stabilize eroding or exposed areas, then ensure that appropriately-sized, clean rock is used; and that rock is installed at a similar slope to maintain a uniform bank/shoreline and natural stream/shoreline alignment.
11. Remove all construction materials from site upon project completion.

# **APPENDIX "B"**

This page has been intentionally left blank

PLAN OF SURVEY OF  
**PART OF LOT 19**  
**CONCESSION 10**  
 GEOGRAPHIC TOWNSHIP OF GOSFIELD NORTH  
**TOWN OF KINGSVILLE**  
 COUNTY OF ESSEX

SCALE 1 : 500 METRES



SURVEYORS ON SITE INC.

THE INTENDED PLOT SIZE OF THIS PLAN IS 609mm IN WIDTH BY 457mm IN HEIGHT WHEN PLOTTED AT A SCALE OF 1:500.

**LEGEND**

□	.....	MONUMENT PLANTED
■	.....	MONUMENT FOUND
SIB	.....	STANDARD IRON BAR
IB	.....	IRON BAR
M	.....	MEASURED
S	.....	SET
P1	.....	PLAN 12R-922
P2	.....	PLAN 12R-7140
1040	.....	WILLIAM J. SETTERINGTON LTD.
1341	.....	RICHARD W. MURRAY, O.L.S.
1528	.....	VERHAEGEN, STUBBERFIELD, HARTLEY, BREWER, BEZAIRE INC.
OU	.....	ORIGIN UNKNOWN
UP	.....	UTILITY POLE
AN	.....	ANCHOR POINT

SCHEDULE				
PART	PART OF LOT	CONCESSION	PART OF PIN	AREA (m <sup>2</sup> )
1	19	10	PIN 75153-0045 (LT)	5097.9

**PLAN 12R-29965**

Received and deposited

December 12<sup>th</sup>, 2024

Maya Fullerton

Representative for the  
 Land Registrar for the  
 Land Titles Division of  
 Essex (No.12)

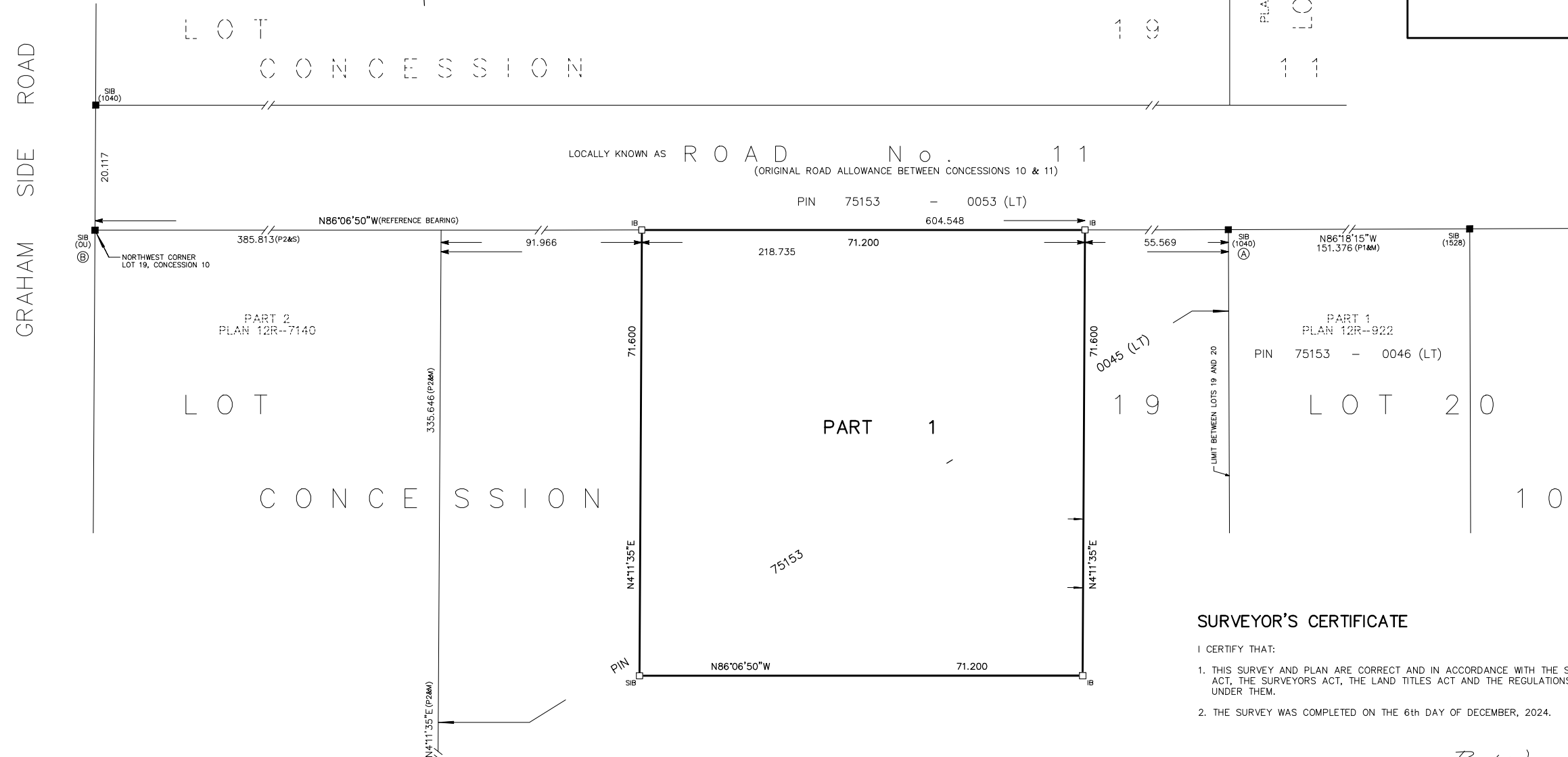

**NOTES**

DISTANCES AND COORDINATES SHOWN ON THIS PLAN ARE IN METRES AND CAN BE CONVERTED TO FEET BY DIVIDING BY 0.3048.

DISTANCES ON THIS PLAN ARE HORIZONTAL GROUND DISTANCES AND CAN BE CONVERTED TO GRID DISTANCES BY MULTIPLYING BY THE AVERAGE COMBINED SCALE FACTOR OF 0.999811236.

BEARINGS ARE UTM GRID DERIVED FROM NETWORK RTK GPS OBSERVATIONS (SMARTNET) ON MONUMENTS (A) AND (B) AS SHOWN HEREON, HAVING A GRID BEARING OF N86°06'50"W, NAD83 CSRS (2010.0) AND ARE REFERRED TO THE CENTRAL MERIDIAN OF UTM ZONE 17 (81° W LONGITUDE).

FOR BEARING COMPARISONS, THE FOLLOWING ROTATIONS WERE APPLIED:  
 P2 - 1°07'05" CLOCKWISE

COORDINATES BELOW ARE DERIVED FROM NETWORK RTK GPS OBSERVATIONS (SMARTNET) AND ARE REFERRED TO UTM ZONE 17, NAD83 (CSRS) (2010.0).

COORDINATES COMPLY WITH THE URBAN ABSOLUTE ACCURACY PER SEC. 14(2) OF O.REG. 216/10.

POINT ID	NORTHING	EASTING
(A)	4669176.42	361200.90
(B)	4669217.38	360597.85

COORDINATES CANNOT, IN THEMSELVES, BE USED TO RE-ESTABLISH CORNERS OR BOUNDARIES SHOWN ON THIS PLAN.

**SURVEYOR'S CERTIFICATE**

I CERTIFY THAT:

1. THIS SURVEY AND PLAN ARE CORRECT AND IN ACCORDANCE WITH THE SURVEYS ACT, THE SURVEYORS ACT, THE LAND TITLES ACT AND THE REGULATIONS MADE UNDER THEM.
2. THE SURVEY WAS COMPLETED ON THE 6th DAY OF DECEMBER, 2024.

DECEMBER 10, 2024

*R. Wannack*  
 ROBERT WANNACK  
 ONTARIO LAND SURVEYOR

THIS PLAN OF SURVEY RELATES TO AOLS PLAN SUBMISSION FORM NUMBER V-92787.



3560 WALKER ROAD  
 WINDSOR, ONTARIO  
 N8W 3S4  
 519-818-0767  
 www.surveyorsonsite.com



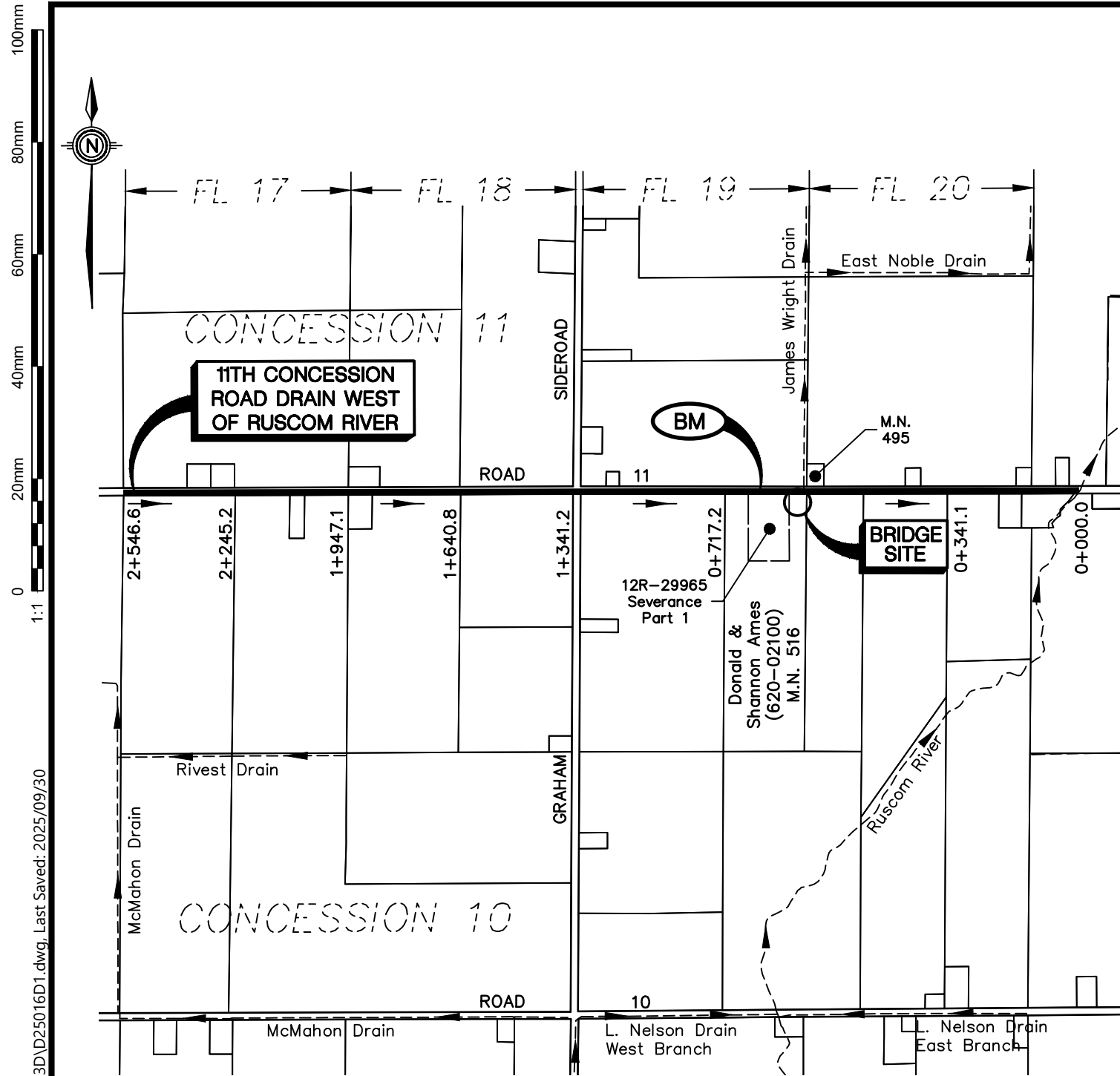

**KEY PLAN**  
Scale = 1:15,000

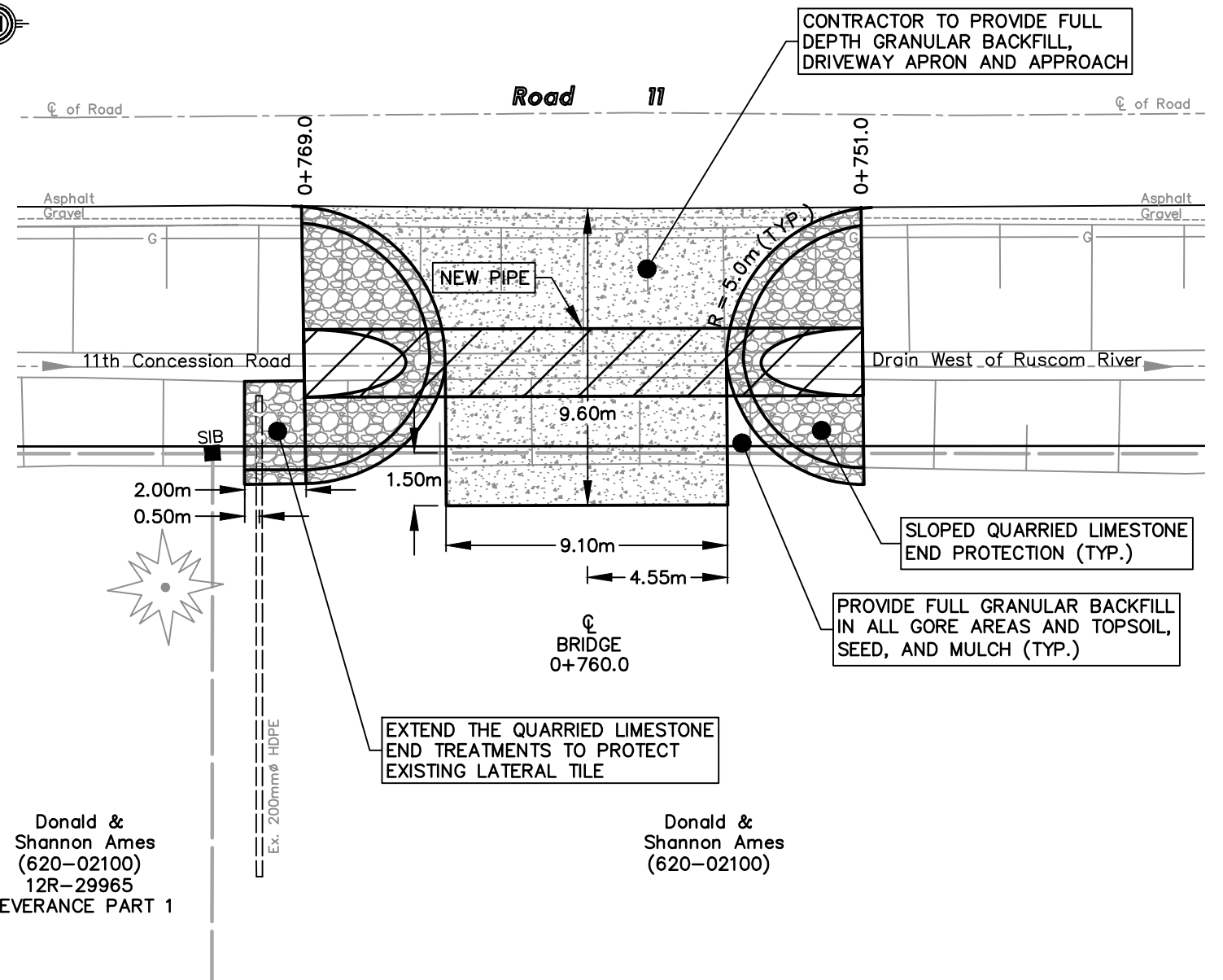

**BRIDGE PLAN**  
Scale = 1:200

**BENCHMARK:**

TOP OF EAST CURB OF CONCRETE ACCESS BRIDGE FOR M.N. 516, LOCATED ON THE SOUTH SIDE OF KINGSVILLE ROAD 11, APPROXIMATELY 300m WEST OF PROPOSED BRIDGE SITE.

**ELEV. = 190.488m**

PIPE SIZE:	PIPE LENGTH:	PIPE GAUGE:	CORRUGATIONS:	TYPE OF PIPE:
2200mm $\phi$	18.0m (59.06 FT.)	2.0mm (14 GA.)	125mm x 25mm (5.0" x 1.0")	ALUMINIZED STEEL CORRUGATED HEL-COR PIPE

**PIPE & DRIVEWAY ELEVATIONS:**

UPSTREAM INV. (W) = 187.556m  
 DOWNSTREAM INV. (E) = 187.545m  
 DESIGN GRADE = 0.06%  
 $\phi$  OF DRIVEWAY AT PAVEMENT ROADWAY EDGE = 190.478m  
 $\phi$  OF DRIVEWAY AT PIPE CENTRELINE = 190.253m  
 $\phi$  OF DRIVEWAY 9.6m SOUTH OF ROADWAY EDGE = 190.055m  
 DRIVEWAY CROSSFALL FROM CENTRELINE TO TOP OUT END OF END WALL = 1.00%

**BRIDGE OVER THE 11TH CONCESSION ROAD DRAIN WEST OF RUSCOM RIVER**  
 (For Donald & Shannon Ames (620-02100), Part of Lot 19, Concession 10)  
 IN THE  
**TOWN OF KINGSVILLE**  
 (Geographic Township of Gosfield North)  
 IN THE  
**COUNTY OF ESSEX • ONTARIO**



N.J. Peralta Engineering Ltd.  
Consulting Engineers

45 Division Street North Kingsville, ON N9Y 1E1 Canada  
 P: 519-733-6587  
 F: 519-733-6588  
 peraltaengineering.com

FILE No.: <b>D25-016</b>	DRAWN BY: S.R.A. DESIGNED BY: S.R.A. CHECKED BY: A.B.P.	SHEET No.: <b>1 OF 1</b>
-----------------------------	---	-----------------------------

DATE: SEPTEMBER 30, 2025

Z:\PROJECTS\DRAINAGE\2025\16\16\CADD\DWG\C3D\16D1.dwg, Last Saved: 2025/09/30