



**Town of Kingsville  
Regular Meeting of Council  
Agenda**

Monday, April 20, 2026, 06:00 PM  
Unico Community Centre  
37 Beech Street  
Kingsville, ON N9Y 1A9

View the livestream at the time of the proceedings at <https://www.kingsville.ca/livestream>.

For information pertaining to this agenda or to arrange for any additional accessibility needs, please contact the Clerk's Office at [clerks@kingsville.ca](mailto:clerks@kingsville.ca).

---

**A. Call to Order**

**B. Land Acknowledgement**

We acknowledge the Three Fires Confederacy (Ojibwe, Potawatomie and Odawa) and the Traditional ancestral, unceded territory of Caldwell First Nation; the original people of Point Pelee, Pelee Island and its surrounding waters. We recognize and respect the First Nations who are stewards of the land and waters of Turtle Island and who have embraced this stewardship since time immemorial. We would also like to acknowledge all the moccasins who have walked lands of Turtle Island.

**C. Moment of Silent Reflection and National Anthem**

**D. Mayor's Welcome and Remarks**

**E. Amendments to the Agenda**

**F. Disclosure of Pecuniary Interest**

When a member of Council has any pecuniary interest, direct or indirect, in any matter which is the subject of consideration at this Meeting of Council (or that was the subject of consideration at the previous Meeting of Council at which the member was not in attendance), the member shall disclose the pecuniary interest and its general nature, prior to any consideration of the matter.

**G. Report Out of Closed Session**

Council entered Closed Session pursuant to Section 239 of the Municipal Act, 2001, on April 13, 2026, at 7:11 p.m. and discussed the following items:

**Item I - Personnel Update** heard under Section 239(2)(b), being personal matters about an identifiable individual, including municipal employees; and, Section 239(2)(d) being labour relations or employee negotiations. There is nothing further to report.

**Item II - Lease Proposal** to be heard under Section 239(2)(c), being a proposed or pending acquisition or disposition of land by the municipality; and, Section 239(2)(k) being a position, plan, procedure, criteria, or instruction to be applied to negotiations. There is nothing further to report.

**Item III - By-law Enforcement Update** to be heard under Section 239(2)(b), being personal matters about an identifiable individual, including municipal employees; Section 239(2)(e), being litigation or potential litigation, including matters before administrative tribunals, affecting the municipality; and, Section 239(2)(f), being advice that is subject to solicitor-client privilege, including communications necessary for that purpose. There is nothing further to report.

**H. Minutes for Adoption**

Page 5

**Recommended Action**

That the following Minutes **be adopted** as presented:

- January 13, 2026, BIA Board of Management Minutes;
- February 10, 2026, BIA Board of Management Minutes;
- February 17, 2026, Fantasy of Lights Committee Minutes;
- March 3, 2026, Pollinate Kingsville Meeting Minutes;
- April 10, 2026, Regular Meeting of Council Minutes

**I. Delegations**

**J. Presentations**

**K. Matters Subject to Notice**

K.1 Ash-Cameron Drain – New Culvert Crossings

Page 30

**Recommended Action**

That the Engineer's Report prepared by R. Dobbin Engineering Inc. pursuant to Section 78 of the Drainage Act, and dated March 12, 2026, for new culvert crossings on the Ash-Cameron Drain, **be adopted**;

And that corresponding By-law 27-2026, being a By-law to provide for the removal of one culvert and the installation of three new culverts over the Ash Cameron Drain, in the Town of Kingsville, in the County of Essex, **be provisionally adopted** during the by-law stage of the agenda.

K.2 Ferry Drain – Improvements to Culvert Crossings

Page 64

**Recommended Action**

That Engineer's Report prepared by R. Dobbin Engineering pursuant to Section 78 of the Drainage Act, and dated March 12, 2026, on for improvements to culvert crossings on Ferry Drain, specifically for a shared crossing for Roll # 450-02501 and Roll # 450-02510; and to legalize a second crossing for Roll# 450-00108, **be adopted**;

And that By-law 28-2026, being a By-law to provide for improvements to the Ferry Drain, in the Town of Kingsville, in the County of Essex, **be provisionally adopted** during the by-law stage of the agenda.

**L. Reports - Planning and Development Services**

L.1 Union Water Drain – Request to Abandon the Section 78 Report

Page 92

**Recommended Action**

That upon the recommendation from the appointed Drainage Engineer, R.C. Spencer, the Section 78 request to extend the outlet of the Union Water Drain **be abandoned**.

- L.2 3rd Concession Branch of the Esseltine Drain – Section 65(3) - 1851 Road 3E Page 98

**Recommended Action**

That the Engineer's Report on the 3<sup>rd</sup> Concession Branch of the Esseltine Drain prepared by R. Dobbin Engineering Inc. and dated January 30, 2026, for a new development at Roll # 290-00113, 1851 Road 3 East, **be adopted**;  
And that a buy-in fee into the 3<sup>rd</sup> Concession Branch of the Esseltine Drain **be set** at \$2,963.00;  
And that 0.76 hectares **be removed** from parcel Roll # 290-00113 into the C.O. Branch of the Fleming Wigle Drain.

**M. Reports - Finance and Corporate Services**

- M.1 Proposal to Establish a Joint Election Compliance Audit Committee with Local Municipalities Page 108

**Recommended Action**

That a Joint Election Compliance Audit Committee **be established** for the 2026-2030 Term of Council;  
And that the Terms of Reference for the Joint Election Compliance Audit Committee, attached hereto as Schedule A, **be adopted**;  
And that By-law 30-2026 being a By-law to Establish a Joint Election Compliance Audit Committee **be adopted** during the By-law stage of this Agenda.

- M.2 2026 Tax Rates and Final Tax Levy By-law Page 118

**Recommended Action**

That By-law 29-2026, being a By-law to provide for the establishment of the tax rates for the Town of Kingsville for the year 2026 and to provide for the final tax levy, **be adopted** during the By-law stage of this Council Agenda.

**N. Consent Agenda**

**O. Notices of Motion**

**P. Unfinished Business and Announcements**

- Q. By-laws** Page 129

**Recommended Action**

That the following By-laws be given a first and second reading:  
By-law 27-2026 being a By-law to provide for the removal of one culvert and the installation of three new culverts over the Ash Cameron Drain, in the Town of Kingsville, in the County of Essex; and,  
By-law 28-2026 being a By-law to provide for improvements to the Ferry Drain, in the Town of Kingsville, in the County of Essex.

**Recommended Action**

That the following By-laws be given three readings and finally pass:  
By-law 29-2026 being a By-law to provide for the establishment of rates for the levy and collection of property taxes in the Town of Kingsville for the year 2026 pursuant to the provisions of the Municipal Act;  
By-law 30-2026 being a By-law to authorize the establishment of a Joint Election Compliance Audit Committee; and,

By-law 31-2026 being a By-law to confirm the proceedings of the Council of the Corporation of the Town of Kingsville at its April 20, 2026, Regular Meeting of Council.

**R. Adjournment**

**Recommended Action**

That the meeting **be adjourned** at X:XX p.m.



# COMMITTEE MINUTES Item H.

FEBRUARY 10TH, 2026, 6:15PM  
CARNEGIE ARTS & VISITORS CENTER

## A. CALL TO ORDER

Tony Gaffan called the Meeting to order at 6:16pm with the following Members in attendance:

### MEMBERS OF BIA BOARD:

Tony Gaffan – Vice Chair  
Abby Jakob - Late  
Delilah Carreira  
Amanda Everaert - Late  
Maria Edwards  
Heather Brown

### MEMBERS OF ADMINISTRATION:

Jodie McIntyre

### TOWN LIASON:

Tara Hewitt

### ABSENT:

Councillor Sheri Lowrie  
Roberta Weston - Chair

### GUESTS:

1. NONE

## B. CLOSED SESSION

**BIA-655-2026** Motion that the Board enter Closed Session at 6:15 pm pursuant to Section 239 of the Municipal Act, 2001, by Heather Brown, seconded by Maria Edwards, to discuss the following item:  
**CARRIED**

**Item I – Legal Advice Regarding BIA Programming** to be heard under Section 239(2)(f), being advice that is subject to solicitor-client privilege, including communications necessary for that purpose.

**BIA-656-2026** Motion that the Board rise from Closed Session at 6:29pm, by Abby Jakob, seconded by Delilah Carreira.  
**CARRIED**

## C. LAND ACKNOWLEDGEMENT

## D. DISCLOSURE OF PECUNIARY INTEREST



# COMMITTEE MINUTES

Item H.

1. NONE.

## E. PRESENTATIONS/DELEGATIONS

1. NONE.

## F. AMENDMENTS TO THE AGENDA

1. NONE.

## G. ADOPTION OF ACCOUNTS

**BIA-657-2026** Motion to refund Ernie's TV due to double payment in 2025, from the KBIA Libro bank account by Abby Jakob and seconded by Heather Brown.

**CARRIED**

**BIA-658-2026** Motion to receive the accounts ending December 2025 by Heather Brown and seconded by Abby Jakob.

**CARRIED**

## H. STAFF REPORTS

BIA General Manager (GM) presented highlights from her report, incorporating the key elements of the KBIA Strategic Plan.

### HIGHLIGHTS:

- LUNAS MI TIENDITA – Money exchange and small grocery store carrying Latin products. Opened Feb 1st
- Attended the Leamington Chamber's AI Essentials on January 22<sup>nd</sup>.
- BLUE MONDAY – January 20th Giveaway – Social Media Giveaway - Stef Stanton was our winner of \$200 in BIA Dollars. Interactions were good, visits were up but new followers weren't as high as expected.
- VALENTINE'S DAY – SOCIAL MEDIA GIVEAWAY – February 11<sup>th</sup> with a teaser released in February
- Love Local Promotion – 2026 – GM meeting with Shop Local 2 Win on final details.
- PROMOTIONAL COMMITTEE - Sheri Lowrie has stepped up and volunteered to be a part of the committee, in lieu of Jason Martin's resignation.



# COMMITTEE MINUTES

Item H.

- BIA Dollar Update – 77.7% of the dollars have been redeemed with Fitness & Activities at 36% of the redemption. Push on social media to remind public to redeem their BIA dollars.
- Best of Windsor/Essex – TWEPI – Despite a push on social media for votes for Kingsville BIA as the Best Shopping District, we did not make the final top 7. The need for a stronger push to vote for 2027 was noted.
- Board discussed potential Board member to replace Jason Martin.
- GM to review Municipal Act regarding elections during term and at end of term for BIA Board members.
- Facebook & Instagram has not had a lot of activity, but followers have increased in the last 28 days.
- The BIA GM & Delilah Carriera met with the Town to begin dialogue regarding collection of the levy.

**BIA-659-2026** Motion to request the Town of Kingsville to revise the BIA levy methodology so that levy revenue generated from new assessment growth, including newly constructed or newly assessed properties within the BIA boundary is added to the existing BIA levy, rather than redistributed across existing levy-paying properties, by Amanda Evereart and seconded by Maria Edwards.

**CARRIED**

**BIA-660-2026** Motion to remove Jason Martin from the KBIA Libro bank account and add Delilah Carreira by Abby Jakob and seconded by Heather Brown.

**CARRIED**

## I. BUSINESS/CORRESPONDENCE – ACTION REQUIRED

1. NONE

## J. MINUTES OF THE PREVIOUS MEETING

**BIA-661-2026** Motion to receive the minutes from January 13<sup>th</sup>, by Maria Edwards, seconded by Heather Brown.

**CARRIED**

## K. NEW AND UNFINISHED BUSINESS

1. BUDGET 2025

- Revenue - Reviewed receiving less from the Town due to not spending the estimated budget amount for Beautification and the Misc revenue GL and the success of the Associate Membership revenue.
- Expenses – Reviewed deficit GLs including contracted services, benefits, AGM & Maintenance.
- Reserves – Used for Shop Local 2 Win campaign, website revamp, and other overages (sound system repairs etc.).
- With an anticipated -\$9,306 deficit at the end of 2025 with unforeseen expenses, additional promotions, website redesigned minus reserves, the overage will be approximately -\$812.

**2. KINGSVILLE NEIGHBOUR MAGAZINE DISCUSSION**

- Discussion was tabled due to additional information that will be provided to the BIA regarding advertising costs and packages for the Kingsville Neighbours Magazine.

**3. AGM UPDATE**

- Current budget update was provided.
- List of participants for the swag bag was presented.
- Discussion of questions to ask the membership at the AGM was discussed.
- It was noted that a Q1 MMM was not required due to the attendance at the AGM.

**L. AMENDMENTS TO THE AGENDA**

1. NONE.

**M. OTHER REPORTS**

1. **FINANCIAL COMMITTEE** – Delilah & Tony
  - No Report
2. **BEAUTIFICATION COMMITTEE UPDATE**– Maria & Amanda
  - No Report
3. **PROMOTIONS COMMITTEE UPDATE** – Abby & Sheri
  - No Report
4. **PERSONNEL COMMITTEE** – Heather

- No Report

5. **COUNCIL REPRESENTATIVE** – Tony Gaffan (in Counselor Lowrie’s absence)

- The Town of Kingsville put in a bid for the KDHS property.
- Council approved Canada Day, Reconciliation Walk Day, Block Party days (July 18<sup>th</sup> & August 15<sup>th</sup>).
- A Buskers Festival was approved for September 11<sup>th</sup> (3pm-10pm) & September 12<sup>th</sup> (9am – 10pm).

6. **TOWN LIASON** – Tara Hewitt

- A new employee will be starting soon to help Tara.
- Focus will be on the Tourism website.
- The Town has placed an ad with TWEPI and KBIA was mentioned as a key stakeholder by the Town.
- Tara is still reviewing the KBIA Carnegie lease regarding allowing non-profit space to other parties.
- Looking at some pre-cinema videos for Kingsville in theatres and review Prime/Netflix advertising.

**N. NEXT MEETING DATE**

- Tuesday, February 24<sup>th</sup>, 2026, 6:30pm – AGM
- Tuesday, March 10<sup>th</sup>, 2026, 6:15pm – Regular Monthly Meeting.

**O. ADJOURNMENT**

- Meeting adjourned at 25pm.

**BIA-662-2026** Motion to adjourn, by Abby Jakob, seconded by Maria Edwards.

**CARRIED**

*Tony Gaffan*  
**ACTING CHAIR, Tony Gaffan**

**Jodie McIntyre**  
**RECORDING SECRETARY, Jodie McIntyre**



# COMMITTEE MINUTES

Item H.

**JANUARY 13<sup>TH</sup>, 2026, 6:15PM  
CARNEGIE ARTS & VISITORS CENTER**

## **A. CALL TO ORDER**

Tony Gaffan called the Meeting to order at 6:16pm with the following Members in attendance:

### **MEMBERS OF BIA BOARD:**

Tony Gaffan – Acting Chair  
Roberta Weston  
Delilah Carreira - Late  
Amanda Everaert - Late  
Maria Edwards  
Abby Jakob - Late  
Heather Brown

### **MEMBERS OF ADMINISTRATION:**

Jodie McIntyre

### **TOWN LIASON:**

Tara Hewitt

### **ABSENT:**

Councillor Sheri Lowrie

### **GUESTS:**

1. NONE

## **B. LAND ACKNOWLEDGEMENT**

## **C. DISCLOSURE OF PECUNIARY INTEREST**

Delilah declared Pecuniary Interest regarding item E. AMENDMENTS TO THE AGENDA, 2. Shop Local 2 Win Promotion.

## **D. PRESENTATIONS/DELEGATIONS**

1. Kingsville Neighbour Magazine – Stephanie Santos
  - Stephanie presented an opportunity for the Kingsville BIA to be an expert contributor to the Kingsville Neighbour Magazine in a similar capacity as the Essex BIA. It would include writing 4 articles a year and sponsoring an ad for one of our BIA businesses, each month at a cost of \$543.60 per month.
  - The Board will discuss the opportunity at the February 10<sup>th</sup> meeting.

## **E. AMENDMENTS TO THE AGENDA**

1. ASK – Use of the Carnegie.
2. Shop Local 2 Win Promotion
3. Chair Resignation – Jason Martin

#### **F. ADOPTION OF ACCOUNTS**

**BIA-647-2026** Moved to receive the accounts ending November 2025 by Roberta Weston and seconded by Amanda Everaert.

**CARRIED**

#### **G. STAFF REPORTS**

BIA General Manager (GM) presented highlights from her report, incorporating the key elements of the KBIA Strategic Plan.

##### **HIGHLIGHTS:**

- Attended Ernie's ribbon cutting, the Small Business & Entrepreneurship Centre's Merry Business Mingle & the Chamber's Jingle & Mingle Holiday Expo.
- Grinch's X-Mas Giveaway – Social Media Giveaway - Our winners Tee Jay & Christine won \$200 in BIA dollars each. New Followers: Facebook – 39, Instagram – 31, 10,064 views& over 800 interactions
- TapCanadian2Win – November 3<sup>rd</sup> – December 14<sup>th</sup> Our final entries for the 6 weeks were 3262. Although there was no winner from Kingsville businesses & customers were still engaged. Economic impact based on the survey will be provided in the new year.
- Christmas at the Carnegie – November 15<sup>th</sup>, 2025 – 3:30pm – 5:30pm. Games provided by Top Shots, DJ Strugzz played & the Sweet Adelines provided Christmas carols just before the parade.
- Christmas at the Corner – December 24<sup>th</sup>, 2026 – 12:30pm – 1:30pm. Featured in the Southpoint Sun. We purchased candy canes to hand out & recruited a Buddy to join the Grinch for some entertainment.
- Social media followers were up 1,5% (8273) from November 6<sup>th</sup> – December 6<sup>th</sup> & up .88% (8346) from December 7<sup>th</sup> – January 7<sup>th</sup>.
- Upcoming events include Blue Monday social media BIA dollar giveaway on January 19<sup>th</sup> & a Valentine's Day social media BIA dollar giveaway on February 11<sup>th</sup>.



# COMMITTEE MINUTES

Item H.

**BIA-648-2026** Motion to receive the General Manager report by Heather Brown, seconded by Roberta Weston.

**CARRIED**

## H. BUSINESS/CORRESPONDENCE – ACTION REQUIRED

1. NONE

## I. MINUTES OF THE PREVIOUS MEETING

**BIA-649-2026** Motion to receive the minutes from November 10<sup>th</sup> & December 1<sup>st</sup> by Amanda Everaert, seconded by Roberta Weston.

**CARRIED**

## J. NEW AND UNFINISHED BUSINESS

1. AGM UPDATE – February 24<sup>th</sup> – Doors: 5:30PM, Meeting: 6:30PM.
  - An update was provided for the AGM including times, format, hall costs, food costs & specifics, door prices, swag bags & entertainment.
  - Maria will provide table clothes & centre pieces Adma Butcher will perform between 5:30pm – 6:30pm and DelFrescoPure will provide vegetables for our swag bags, all within our designated budget.
2. BIA DOLLAR UPDATE
  - BIA dollars sold out in 2 ½ hours on November 13<sup>th</sup>, 2025.
  - As of January 8<sup>th</sup>, 73% of BIA dollars have been redeemed.
  - Top 3 redemption classifications: Fitness & Activities – 36%, Home Furnishings & Improvements – 30%, Restaurants – 14%
  - During the sale of BIA dollars RBC identified a reconciliation variance in the amount of \$408. After review & discussion, the Board acknowledged that while the variance was unfortunate, it was determined to be part of the cost of administration of the program. The Board agreed that the BIA would absorb the loss and no further action will be taken.

**BIA-650-2026** Motion that the Kingsville BIA accept the reconciliation variance of \$408 identified by RBC in the administration of the Kingsville BIA Dollar program, and that the Kingsville BIA absorb the loss as part of the cost of doing business, by Roberta Weston, seconded by Maria Edwards.

**CARRIED**

3. TWEPI ADVERTISING OPPORTUNITY

- The BIA has the opportunity to advertise in the TWEPI Visitor Guide.
- Due to the high cost and the fact that the Town of Kingsville & EDDK will be advertising in the guide the BIA has opted out of advertising in the guide as well.

**AMENDMENTS TO THE AGENDA**

1. ASK – Use of the Carnegie

- Direction from Roberta Weston, seconded by Abby Jakob, to all ASK to utilize the BIA lower level of the Carnegie space once a week as long as it is for non-profit (not paying an instructor but only charging to cover costs), with the understanding that the space must be left as found, ASK is responsible for any damages, if the BIA needs the space they will take priority, the Town of Kingsville agrees to the arrangement and that arrangement can be terminated at any time..

2. Shop Local 2 Win Promotion

- Due to the fantastic success of last year's spring promotion Libro in collaboration with Shop Local 2 Win is providing 8 local BIAs the opportunity to run a similar promotion from May 4<sup>th</sup> – June 14<sup>th</sup>, 2026. The cost of the promotion will be less than \$4,000 covering participation fees and printing costs.
- Each week 1 customer and 1 local business will win \$500 each for a total of \$6,000 in community prizes. Shoppers can enter with any receipt of \$10 or more from a local restaurant, retailer, or service provider.
- The KBIA GM has been given direction to speak on behalf of the KBIA, sharing the positive and successful experience the 2025 spring promotion was, with other potentially participating southwestern BIAs.

**BIA-651-2026** Motion to participate in the 2026 Shop Local 2 Win promotion at a cost pf less than \$4,500, by Heather Brown, seconded by Abby Jakob.

**CARRIED**

3. Chair Resignation – Jason Martin

- The Board acknowledged the official resignation of Jason Martin as current Chair.
- Heather Brown nominated Roberta Weston to assume the position of Chair of the BIA Board of Management. No further nominations were brought forward.
- A vote was held, and the Board voted unanimously in favour of appointing Roberta Weston as Chair.

**BIA-652-2026** Motion that Roberta Weston be appointed as Chair of the Kingsville BIA Board of Management, effective immediately, following the resignation of the previous Chair, by Heather Brown, seconded by Delilah Carreira.

**CARRIED**

- Jason will be removed from the BIA bank account and his position on the Promotional Committee will be replaced.
- A \$150 EDDK gift card will be purchased and sent to Jason to thank him for all the years of dedication to the Kingsville BIA.

**BIA-653-2026** Motion to extend the meeting by 15 minutes, by Heather Brown, seconded by Delilah Carreira.

**CARRIED**

## **K. OTHER REPORTS**

1. **FINANCIAL COMMITTEE** – Delilah & Tony

- No Report

2. **BEAUTIFICATION COMMITTEE UPDATE**– Maria & Amanda

- Christmas décor. is currently being removed by the Town. The garland from the 8 poles at the 4 corners were delivered to the BIA office to evaluate the replacement of old decorated garland.
- All bows & ribbon need to be reassessed and potentially replaced before décor goes out in November 2026.
- Heather Brown has inquired if the tree at the Carnegie can be decorated next November by the BIA or another collaboration with the Town of Kingsville. The BIA GM will follow up with the request.

3. **PROMOTIONS COMMITTEE UPDATE** – Jason & Abby.

- No Report

4. **PERSONNEL COMMITTEE** – Roberta & Heather

- Heather Brown has the HR Policy draft and will review.
- Heather will meet with Jodie in the next week regarding her contract.

**5. COUNCIL REPRESENTATIVE – Sheri Lowrie**

- November 17<sup>th</sup> Meeting of Council
    - Subdivision agreement for Gardner Estates (near Cindy's), 2026 Fees and Charges were adopted, 2026 Water and Sewage Rates were adopted, Essex County O.P.P. Detachment Board South – suspended any further expenditures until budget allocations are resolved.
  - December 10<sup>th</sup> Budget Meeting
    - \$2.6 million for road reconstruction and resurfacing, \$1.4 million for bridge replacements and rehabilitations, \$270,000 for sidewalk replacements, \$619,000 in increased contributions to road, bridge, facility, and park and fleet lifecycle reserves to address historical funding deficits, \$1.2 million to replace Engine 122, a key fire response vehicle, \$625,000 to replace the Town's aging street sweeper ("Pig Pen"), 2 current positions that hold budget line items were increased. The Manager of Parks & Facilities has been changed to a Director of Parks & Recreation role and the Communications team will see a change from their part time position into a full-time position. No 'new' positions were added to 2026, The municipal tax increase is 5.9%, which represents an annual increase of \$126.07 on the average home in Kingsville. (Based on MPAC assessment, the average household in Kingsville is assessed at approximately \$250,000 - 2016 assessment rates), 2.1% of the tax increase (or \$44.91 on the average home in Kingsville) is from a \$535,107 increase to the Town's Ontario Provincial Police (OPP) contract related to new, province-wide OPP wage contracts outside of Council's control, The overall tax rate increase, when combined with County and Education rates, will be 4%.
  - December 15<sup>th</sup> Meeting of Council
    - We have launched a new website (great job and shout out to Tara) and some things are still being populated.
  - January 5<sup>th</sup> Meeting of Council
    - Council approved the Town of Kingsville's 2040 Accessibility Plan (5 year update)
- Fantasy of Lights Festival & New Years Celebration were wonderful events over the holiday break.

**6. TOWN LIASON – Tara Hewitt**

- Tara distributed the Town Annual Report 2025



# COMMITTEE MINUTES

Item H.

- The new Town website has been launched. & the Tourism site is next.
- Currently interviewing for a full-time communications employee and looking at future tourism opportunities.

## L. NEXT MEETING DATE

- Tuesday, February 10th, 2026, 6:15pm.

## M. ADJOURNMENT

- Meeting adjourned at 8:45pm.

**BIA-654-2026** Motion to adjourn, by Abby Jakob, seconded by Maria Edwards.

**CARRIED**

*Tony Gaffan*

**ACTING CHAIR, Tony Gaffan**

**Jodie McIntyre**

**RECORDING SECRETARY, Jodie McIntyre**



**Pollinate Kingsville Committee  
Minutes**

Tuesday, March 03, 2026, 06:00 PM  
Kingsville Arena Complex  
1741 Jasperson Drive  
Kingsville, ON N9Y 3J4

**Present:**

Kimberly DeYong, Deputy Mayor  
Alan Batke  
Sue Novotny  
Carol Dunn, Chair  
Jessica Towle  
Peggy Kennedy

**Absent:**

Erin Hemphill

**Staff Present:**

Toni Ramsey, Recording Secretary

---

**A. Call to Order**

The Chair called the meeting to order at 6:00 p.m.

**B. Disclosure of Pecuniary Interest**

The Chair asked members if there were any disclosures of pecuniary interest. None were noted.

**C. Adoption of Minutes**

**Moved By:** Sue Novotny

**Seconded By:** Jessica Towle

That the Minutes of the Pollinate Kingsville Committee meeting dated February 3, 2026,  
**be adopted** as presented.

**Carried**

**D. Items for Consideration**

**D.1 Town Support for May Event**

Toni Ramsey, Staff Liaison, informed the committee that a Part-time staff member will be scheduled to help with cash/debit sales at the Nature and Garden Show. Carol will provide Toni Ramsey with a request of scheduled hours required for event support.

Committee has requested 'Market Today' signage from the Special Event department. Volunteers and Committee members will be responsible for setup and take down of the requested signage. Carol will reach out to Special Events department to coordinate pickup and return of signage.

#### D.2 Calendar Invites

Carol will send dates related to the Work Plan and Special Events to recreation@kingsville.ca. Town staff will send out invites to Committee members. Council calendar invites will be sent out for specific events at the Towns discretion.

#### D.3 Letter to neighbours of York Park

Carol has crafted a letter for residents adjacent to York Park informing them of a future native plant bed installation. The letter has been sent to the Towns Supervisor of Communications, Marketing and Tourism Tara Hewitt for review. The Committee will hand out letters to residents once it has been approved.

#### D.4 Reaching out to Volunteers

Toni Ramsey, Staff Liaison informed the committee that there are two (2) approaches to recruiting volunteers.

1. The committee can recruit volunteers on their own and direct them to <https://www.kingsville.ca/volunteer/>. There they will be able to sign up for specific events they are interested in and complete the volunteer application required by the town.
2. If the committee requires more volunteers than they can recruit, they can reach out to Programs and Special Events Manager, Karen Loney for assistance.

#### D.5 Budget/balance

Toni Ramsey, Staff Liaison, presented the 2026 budget to the Committee. Additionally, she informed the Committee that \$9000 of the budget that was not spent for Communities in Bloom judging was set aside for future projects of the Pollinate Kingsville Committee as directed by Council. The fundraising amount of \$3801 from 2025 is being held and will be discussed at a future council meeting.

#### D.6 Finalizing Work Plan and Communication Plan

Committee Chair Carol reviewed the work plan and latest updates with Committee members. 'Mettawas' Landsdowne Avenue to Parks Street Greenway adoption location was confirmed by ERCA for 2026.

**Moved By:** Jessica Towle

**Seconded By:** Sue Novotny

The Committee moves to cancel the June 2, 2026 6:00 p.m. meeting at Kingsville Arena Complex. This will become a working date for ERCA cleanup.

**Carried**

#### D.7 ISA Update – Trees for pollinators

Toni Ramsey, Staff Liaison, formally requests the committee consider incorporating native tree planting to support pollinators into future projects when

possible. Staff Liaison suggested reaching out to ERCA for assistance with future project planning and possible grant funding.

D.8 Volunteer Appreciation Night

Toni Ramsey, Staff Liaison reminded Committee members of RSVP if they are interested in the Volunteer Appreciation Night at the Grovedale. They are entitled to bring a plus one (1).

D.9 Reimbursement for supplies

**Moved By:** Kimberly DeYong, Deputy Mayor

**Seconded By:** Alan Batke

Motion by Committee to reimburse Carol for display expenses related to the Nature and Garden Show totaling \$162.00.

Staff Liaison, Toni Ramsey reminded Carol to submit receipts to the Town for budget items.

**Carried**

**E. Next Meeting Date**

To cancel next committee meeting April 7, 2026 at 6:00p.m. to a working group.

Next regularly scheduled meeting of the Pollinate Kingsville Committee would be May 5, 2026 at 6:00 p.m. at the Kingsville Arena Complex

**Lost**

Committee will move forward with the regularly scheduled meeting on April 7, 2026 at 6:00 p.m. at the Kingsville Arena Complex. After the meeting has concluded work can be done to prepare for the Nature and Garden Show.

Toni Ramsey, Staff Liaison, will look into booking a room at the Kingsville Arena Complex to provide more space.

**F. Adjournment**

**Moved By:** Kimberly DeYong, Deputy Mayor

**Seconded By:** Peggy Kennedy

That the meeting **be adjourned** at 6:59 p.m.

**Carried**

**FANTASY OF LIGHTS COMMITTEE**

February 17, 2026 – 5:00 pm  
Kingsville Arena – Board Room  
1741 Jasperson Drive, Kingsville

**PRESENT:** Chair Councillor Tony Gaffan  
Dave Laman  
Glenda Willemsma  
Maria Edwards  
Karen Loney, Staff Liaison

**REGRETS:** Doug Woolridge  
Janet Willoughby  
Leslie Pittendreigh

**A. CALL TO ORDER**

Chair Councillor Tony Gaffan called the meeting to order at 4:57 pm

**B. DISCLOSURE OF PECUNIARY INTEREST**

The Chair reminded the Committee of its duty to disclose any pecuniary interests as they arise.

**C. MINUTES OF THE PREVIOUS MEETING**

1. Fantasy of Lights Committee Meeting Minutes – December 16, 2026

**Moved by Dave Laman**

**Seconded by Maria Edwards**

**THAT the minutes of the Fantasy of Lights Committee dated December 16, 2026, BE ADOPTED.**

**CARRIED**

**D. ORDER OF BUSINESS**

1. New Year's Eve Celebration – Review
  - i. Well organized

- ii. The weather impacted the event's numbers
2. Logo Review
  - i. Reviewed and will send to the designer changes to place on the next agenda for voting
3. Kingsville Express Evenings

**Moved by Maria Edwards**

**Seconded by Glenda Willemsma**

**THAT the music is offered to the community both Friday and Saturday, excluding the market weekend, BE APPROVED.**

**CARRIED**

4. Parade Item Giveaway

Council ran out of the 2500 bracelets purchased last year.

**Moved by Dave Laman**

**Seconded by Maria Edwards**

**THAT up to \$3,000 be allocated to a parade item giveaway, and it does not need to be branded, Kingsville BE APPROVED.**

**CARRIED**

#### **E. STAFF REPORTS**

1. Breakfast with Santa

The Santa Claus performer is unavailable on December 12 for Breakfast with Santa.

**Moved by Glenda Willemsma**

**Seconded by Dave Laman**

**THAT \$400.00 is allotted to contract a Santa Claus performer for Breakfast with Santa, BE APPROVED.**

**CARRIED**

**F. INFORMATION ITEMS**

1. Fantasy of Lights light display
  - i. To arrange an internal meeting regarding reserve funding for lights.
2. Fantasy of Lights Parade – Saturday, November 21
  - i. No update
3. Flip the Switch – Saturday, November 21

**Moved by Glenda Willemsma**

**Seconded by Maria Edwards**

**THAT the same singer as last year be APPROVED to perform.**

**CARRIED**

4. Kingsville Express Evenings – Friday, November 27 to Sunday, December 20
  - i. No update
5. Paws and Claus – Tuesday, December 1
  - i. No update
6. Fantasy of Lights Market – Sat, December 5 and Sun, December 6
  - i. No update
7. Breakfast with Santa – Saturday, December 12
  - i. No update
8. Fantasy of Lights New Year's Eve - Thursday, December 31
  - i. No update
9. Gingerbread House Update
  - i. No update

**G. NEXT MEETING DATE**

Tuesday, March 17, 2026

**H. ADJOURNMENT**

**Moved by Dave Laman**

**Seconded by Glenda Willemsma**

**THAT the meeting adjourn at 6:17 p.m.**

**CARRIED**



# COMMITTEE MINUTES

Item H.

---

**CHAIR, Cllr. Tony Gaffan**

---

**RECORDING SECRETARY, Karen Loney**



**Regular Meeting of Council  
Minutes**

Monday, April 13, 2026, 06:00 PM  
Unico Community Centre  
37 Beech Street  
Kingsville, ON N9Y 1A9

**Present:**

Mayor Dennis Rogers  
Deputy Mayor Kimberly DeYong  
Councillor Tony Gaffan  
Councillor Debby Jarvis-Chausse  
Councillor Sheri Lowrie  
Councillor Thomas Neufeld  
Councillor Larry Patterson

**Absent:**

**Staff Present:**

John Norton, Chief Administrative Officer  
Nada Tremblay, Director of Parks and Recreation  
Ryan McLeod, Director of Finance and Corporate Services/Treasurer  
Richard Wyma, Director of Planning and Development  
Shaun Martinho, Director of Public Operations  
Scott Moore, Fire Chief  
William Good, Manager of Legal Services  
Angela Toole, Manager of Municipal Governance/Clerk

---

**A. Call to Order**

Mayor Rogers called the meeting to order at 6:00 p.m.

**B. Land Acknowledgement**

Mayor Rogers read the Land Acknowledgement Statement.

**C. Moment of Silent Reflection and National Anthem**

**D. Mayor's Welcome and Remarks**

Mayor Rogers welcomed members of the public in attendance and those viewing remotely. He noted that Council and Administration were wearing yellow daffodils in recognition of the Canadian Cancer Society's annual Daffodil Campaign. The daffodil was described as a symbol of hope, renewal, and resilience, with the campaign supporting life-saving cancer research and essential programs and services for individuals and families affected by cancer. Wearing the daffodils signified solidarity with those impacted by cancer and support for a future without the disease.

Mayor Rogers also recognized Corbin Watson, a Kingsville resident and Paralympian in para ice hockey, for outstanding achievements and community ambassadorship. Mr. Watson was acknowledged for representing Canada at the Milano Cortina 2026 Paralympic Winter Games, where Team Canada earned a silver medal. His athletic accomplishments, dedication, and resilience were highlighted as a source of inspiration to the community. On behalf of Council and the residents of Kingsville, appreciation was expressed for Mr. Watson's representation of the municipality, and he was invited forward to receive a Certificate of Recognition.

#### **E. Amendments to the Agenda**

None noted.

#### **F. Disclosure of Pecuniary Interest**

Mayor Rogers reminded Council that any declaration is to be made prior to each item being discussed and to identify the nature of the conflict, if any, as the agenda items come forward.

None disclosed.

#### **G. Report Out of Closed Session**

The Clerk gave the following report out of Closed Session:

Council entered Closed Session pursuant to Section 239 of the Municipal Act, 2001, on March 23, 2026, at 5:00 p.m. and discussed the following item:

**Item I - Legal Update** heard under Section 239(2)(e) being litigation or potential litigation, including matters before administrative tribunals, affecting the municipality; and, Section 239(2)(f) being advice that is subject to solicitor-client privilege, including communications necessary for that purpose. There is nothing further to report.

#### **H. Minutes for Adoption**

**072-13042026**

**Moved By:** Councillor Lowrie

**Seconded By:** Councillor Patterson

That the following Minutes **be adopted** as presented:

- February 11, 2026, Kingsville Accessibility Advisory Committee Minutes
- February 17, 2026, Fantasy of Lights Committee Minutes
- March 2, 2026, Committee of the Whole
- March 3, 2026, Kingsville Municipal Heritage Advisory Committee Minutes
- March 23, 2026, Regular Council Meeting Minutes

**Carried**

#### **I. Delegations**

Walter Branco, resident and developer at Noah Homes, appeared as a delegation regarding Item L.1. Interim Control By-law 24-2025 related to Sanitary Sewer Constraints in Ruthven. Mr. Branco expressed opposition to the recommended action, specifically regarding residential development.

#### **J. Presentations**

None.

**K. Matters Subject to Notice**

None.

**L. Reports - Planning and Development Services**

L.1 Interim Control By-law 24-2025 related to Sanitary Sewer Constraints in Ruthven

John Norton, CAO, and Richard Wyma, Director of Planning and Development, provided an overview of the report.

**073-13042026**

**Moved By:** Deputy Mayor DeYong

**Seconded By:** Councillor Patterson

That Interim Control By-law 24-2025 as amended by By-law 46-2025 **be extended** one additional year in keeping with *Planning Act* Section 38 (2) to allow the Town to complete its review and study in respect of the Town's land use planning policies in relation to required changes to the Town's land use planning policies, and other regulatory frameworks as a result of the Town's sanitary sewer constraints for the lands reliant on the Ruthven Sanitary System; including:

- a. the development of a Comprehensive Sewer Use By-law and amendments to associated By-laws; and
- b. substantial completion of the Water and Wastewater Servicing Master Plan and confirmation of servicing capacity; and,
- c. preparation of Official Plan and Zoning By-law Amendments to create new "Future Urban Development" policies to permit existing and compatible agricultural uses while protecting the lands for future development; and based on studies required to support proposed development.

And that the issuance of building permits on residential and industrial buildings within existing plans of subdivision, **be permitted** to continue.

For (6): Councillor Gaffan, Councillor Patterson, Councillor Jarvis-Chausse, Deputy Mayor DeYong, Councillor Lowrie, and Mayor Rogers

Against (1): Councillor Neufeld

**Carried (6 to 1)**

L.2 2026 Road Resurfacing - Tender Approvals

Dan Baughan, Engineering Technician, provided an overview of the report.

**074-13042026**

**Moved By:** Councillor Patterson

**Seconded By:** Councillor Gaffan

That the 2026 Rural Road Resurfacing Tender **be awarded** to Shepley Road Maintenance Ltd. in the amount of \$1,257,934.07 (excluding HST);

And that the 2026 Urban Road Resurfacing Tender **be awarded** to GIP Paving Inc. in the amount of \$664,400 (excluding HST);

And that the Mayor and Clerk **be authorized** to execute the requisite agreements.

For (7): Mayor Rogers, Deputy Mayor DeYong, Councillor Jarvis-Chausse, Councillor Gaffan, Councillor Neufeld, Councillor Patterson, and Councillor Lowrie

**Carried (7 to 0)**

**M. Reports - Finance and Corporate Services**

None.

**N. Reports - Fire Rescue Services**

None.

N.1 Kingsville Fire Emergency Response Cost Recovery  
Scott Moore, Fire Chief, provided an overview of the report.

**075-13042026**

**Moved By:** Councillor Gaffan

**Seconded By:** Deputy Mayor DeYong

That Council **authorize** Administration to enter into and execute an agreement with Fire Marque Inc. for the purpose of cost recovery for insured perils, and to establish a schedule of rates for fire department services based on Ministry of Transportation (MTO) rates per apparatus.

For (7): Deputy Mayor DeYong, Councillor Neufeld, Councillor Patterson, Councillor Jarvis-Chausse, Councillor Gaffan, Councillor Lowrie, and Mayor Rogers

**Carried (7 to 0)**

**O. Reports - Public Operations**

None.

**P. Reports - Office of the CAO**

None.

**Q. Consent Agenda**

None.

**R. Notices of Motion**

R.1 Deputy Mayor DeYong - Support for Finlay's Law  
Deputy Mayor DeYong presented a Notice of Motion for Council's consideration.

**076-13042026**

**Moved By:** Deputy Mayor DeYong

**Seconded By:** Councillor Lowrie

**Whereas** it has been reported that on February 7, 2024, 16-year-old Finlay van der Werken from Burlington waited more than eight hours in the emergency department at Oakville Trafalgar Memorial Hospital without being seen by an emergency physician and subsequently died on February 9, 2024;

**And whereas** reports indicate Finlay was triaged as Priority Level 2 under the Canadian Triage and Acuity Scale, which requires physician assessment within 15 minutes for that level of acuity;

**And whereas** the van der Werken family has launched Finlay's Voice, a public campaign advocating reforms for emergency care for pediatric patients, including a petition proposing Finlay's Law to set maximum ER wait times for children, require safe pediatric staffing ratios, mandate independent reviews of pediatric ER deaths, and fund enhanced pediatric emergency readiness;

**And whereas** the Provincial Government has taken steps to improve health care in Ontario, however additional funding, staffing and changes to ER wait times are needed to reduce emergency department wait times and ensure timely and safe care for children;

**Now therefore be it resolved** that Council calls on the Provincial Government to enact legislation known as Finlay's Law to:

1. Establish legal maximum wait time standards for patients under 18 (i.e. physician assessment within 2 hours, admission within 8 hours);
2. Require safe pediatric nurse-to-patient and physician-to-patient ratios in emergency settings;
3. Create an independent oversight body with authority to audit hospitals emergency departments, investigate pediatric deaths that occur in ER waiting areas, and enforce compliance;
4. Mandate timely public, independent reviews of every pediatric death in an ER waiting area or while awaiting assessment; and
5. Provide dedicated provincial funding to improve pediatric emergency readiness, including staffing, training, and pediatric equipment;

And that a copy of this resolution be sent to the Premier of Ontario, the Ontario Minister of Health, the Chair of the Board of Directors of Windsor Regional Hospital and Hotel-Dieu Grace Healthcare, local MPPs, and the Association of Municipalities of Ontario.

For (7): Councillor Lowrie, Councillor Patterson, Deputy Mayor DeYong, Councillor Gaffan, Mayor Rogers, Councillor Jarvis-Chausse, and Councillor Neufeld

**Carried (7 to 0)**

#### **S. Unfinished Business and Announcements**

None.

#### **T. By-laws**

**077-13042026**

**Moved By:** Deputy Mayor DeYong

**Seconded By:** Councillor Jarvis-Chausse

That the following By-laws be given three readings and finally pass:

By-law 25-2026 - Being a By-law to extend By-law 24-2025, being a By-law to Establish Interim Control on Lands within the Corporation of the Town of Kingsville, as amended.

By-law 26-2026 - Being a By-law to confirm the proceedings of the Council of the Corporation of the Town of Kingsville at its April 13, 2026, Regular Meeting of Council

**Carried**

#### **U. Closed Session**

**078-13042026**

**Moved By:** Councillor Patterson

**Seconded By:** Councillor Lowrie

That Council enter into Closed Session at 7:11 p.m. pursuant to Section 239(2) of the Municipal Act, 2001, to discuss the following items:

**Item I - Personnel Update** to be heard under Section 239(2)(b), being personal matters about an identifiable individual, including municipal employees; and, Section 239(2)(d) being labour relations or employee negotiations;

**Item II - Lease Proposal** to be heard under Section 239(2)(c), being a proposed or pending acquisition or disposition of land by the municipality; and, Section 239(2)(k) being a position, plan, procedure, criteria, or instruction to be applied to negotiations; and,

**Item III - By-law Enforcement Update** to be heard under Section 239(2)(b), being personal matters about an identifiable individual, including municipal employees; Section 239(2)(e), being litigation or potential litigation, including matters before administrative tribunals, affecting the municipality; and, Section 239(2)(f), being advice that is subject to solicitor-client privilege, including communications necessary for that purpose.

**Carried**

**V. Adjournment**

**079-13042026**

**Moved By:** Deputy Mayor DeYong

**Seconded By:** Councillor Jarvis-Chausse

That Council **rise** from Closed Session and **adjourn** its Regular Meeting of Council at 8:50 p.m.

**Carried**

---

Mayor, Dennis Rogers

---

Clerk, Angela Toole

## The Corporation of the Town of Kingsville

**To:** Mayor and Members of Council

**Prepared By:** Lu-Ann Marentette, Drainage Superintendent

**Department:** Planning and Development - Capital Projects and Engineering

**Date of Meeting:** April 20, 2026

**Subject:** Ash-Cameron Drain – New Culvert Crossings

---

### Recommended Action

That the Engineer's Report prepared by R. Dobbin Engineering Inc. pursuant to Section 78 of the Drainage Act, and dated March 12, 2026, for new culvert crossings on the Ash-Cameron Drain, **be adopted**;

And that corresponding By-law 27-2026, being a By-law to provide for the removal of one culvert and the installation of three new culverts over the Ash Cameron Drain, in the Town of Kingsville, in the County of Essex, **be provisionally adopted** during the by-law stage of the agenda.

### Background

The owner of Roll # 570-00700 came to the municipality requesting a new crossing and a replacement of a second crossing in a different location on his farm parcel. Then the owner of Roll # 570-00800 requested a new culvert crossing as a result of a severance. Both of these requests were received under Section 78 of the Drainage Act.

### Discussion

R. Dobbin Engineering was hired to prepared the requisite Engineer's Report. The Report is attached for review. At the site meeting and during the investigation, it was determined that a new profile would be required on the drain as well.

This Report was sent to all affected landowners, and a public information session was held on March 11, 2026. No concerns were received.

### Financial Considerations

Total cost of construction and engineering	\$130,560
Landowners	\$ 129,880
County Road 34	\$ 139
Kingsville Roads – Cameron, South Talbot	\$ 541

**Environmental Considerations**

Prior to construction ERCA permit will be required.

**Consultations**

R. Dobbin Engineering  
ERCA

**Prepared By:**

A handwritten signature in blue ink that reads "Lu-Ann Marentette". The signature is written in a cursive style with a large initial 'L'.

Lu-Ann Marentette  
Drainage Superintendent

**Report Approval Details**

Document Title:	Ash-Cameron Drain - New Culvert Crossings.docx
Attachments:	Ash-Cameron Drain Final Report (March 12 2026).pdf
Final Approval Date:	April 15, 2026

This document and all of its attachments were approved and signed as outlined below:

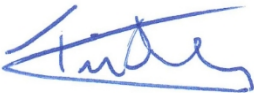

Tim Del Greco, Senior Manager of Capital Projects and Engineering



Richard Wyma, Director of Planning and Development



John Norton, Chief Administrative Officer



4218 Oil Heritage Road  
Petrolia, Ontario, N0N 1R0  
Phone: (519) 882-0032 Fax: (519) 882-2233  
www.dobbineng.com

March 12, 2026

The Mayor and Council  
The Corporation of the  
Town of Kingsville  
2021 Division Road North  
Kingsville, Ontario  
N9Y 2Y9

**Re: Ash-Cameron Drain**

In accordance with your instructions, we have undertaken an examination of the Ash-Cameron Drain with regards to making drainage improvements in Lot 275, Concession South Talbot Road in the Town of Kingsville. The work includes the installation of three new culverts and the removal of one culvert.

Authorization under the *Drainage Act*

This Engineers Report has been prepared under Section 78 of the *Drainage Act* as per the request of an affected Owner.

R. Dobbin Engineering Inc. was appointed June 19, 2025.

Section 78 of the *Drainage Act* states that, where, for the better use, maintenance or repair of any drainage works constructed under a bylaw passed under this *Act*, or of lands or roads, it is considered expedient to change the course of the drainage works, or to make a new outlet for the whole or any part of the drainage works, or to construct a tile drain under the bed of the whole or any part of the drainage works as ancillary thereto, or to construct, reconstruct or extend embankments, walls, dykes, dams, reservoirs, bridges, pumping stations, or other protective works as ancillary to the drainage works, or to otherwise improve, extend to an outlet or alter the drainage works or to cover the whole or any part of it, or to consolidate two or more drainage works, the Council whose duty it is to maintain and repair the drainage works or any part thereof may, without a petition required under Section 4 but on the report of an Engineer appointed by it, undertake and complete the drainage works as set forth in such report.

### Existing Drainage

The Ash-Cameron Drain is an open channel drain located in Lot 275, Concession South Talbot Road. The drain outlets into the 9<sup>th</sup> Concession Road Drain Extension. The drain begins at the tee portion of a culvert that crosses under South Talbot Road. The drain extends upstream along the north side of South Talbot Road for approximately 171 meters where it turns to the north. It then extends north along the east side of Cameron Sideroad for approximately 997 meters. At this point, the drain turns east and extends across the property with roll no. 570-00701 for approximately 65 meters. The drain then turns north and runs along the backside of the properties that front onto Cameron Sideroad and along the backside of the properties that front onto County Road #34.

The drain was last improved under an Engineer's Report dated July 25, 1994, prepared by Bruce D. Crozier Engineering Inc. Under this report, the Ash-Cameron Drain was created.

### On-site Meeting

An On-site Meeting was held on September 17, 2025.

The following were present at the meeting:

- David Moores (R. Dobbin Engineering)
- Lu-Ann Marentette (Town of Kingsville)
- Clare Janisse (Town of Kingsville)
- Mark Fishleigh (County of Essex)
- Jim – Rivard Engineered Products (Landowner)
- Peter Ketler (Landowner)
- Jeff Patterson (Landowner)
- Deb Lamier (Landowner)
- Dan Poisson (Landowner)

The following is a brief summary of the meeting:

- General discussion of the *Drainage Act* and Landowners rights under the *Drainage Act*.
- Landowners were made aware that the Town received two requests for three new culverts in the Ash-Cameron Drain and that this was the first step in the public process.
- These culverts will be assessed 100% against the benefiting owner.
- The landowner for the property with Roll No. 570-00700 also requested that an existing culvert be removed from the drain. This culvert is identified as Culvert No.3 on the drawings.

- The Engineer informed the landowners that the drain should be maintained. The Drainage Superintendent said she would take care of that.
- No other concerns were received.

Discussion and Investigation

The drain was surveyed for its entire length to verify the channel grade for the drain bottom to ensure the new culverts are installed correctly. The open channel is in need of bottom cleanout. At the On-site Meeting, those landowners in attendance did not want any additional work completed. Maintenance of the drain can be addressed, in the future, by the Drainage Superintendent. This Report will provide an updated profile for the drain.

An investigation of each culvert was completed and a summary is shown below:

<b>Culvert No.</b>	<b>Location</b>	<b>Existing Culvert Information</b>	<b>Condition</b>
1	Sta. 0+000 Shared Culvert with Roll No. 570-00799 & South Talbot Road	23m x 1500mm dia. CSP This culvert is part of the Ash-Cameron Drain and the 9 <sup>th</sup> Concession Road Drain Extension	Fair condition with a couple of holes throughout and some rust starting on the inside of the pipe. The pipe still has some life expectancy left, but should be inspected annually.
2	Sta. 0+393 Roll No. 570-00700 (Secondary Access Culvert)	N/A	New Culvert Location
3	Sta. 0+840 Roll No. 570-00700	7m x 450mm dia. HDPE	Good condition, but undersized for the drain. Landowner requested for this culvert to be removed from the drain.

Culvert No.	Location	Existing Culvert Information	Condition
4	Sta. 0+973 Roll No. 570-00700 (Main Access Culvert)	25m x 600mm dia. CSP This culvert is considered the primary access to the property.	Due to the amount of water and sediment in the drain, the culvert could not be inspected. This culvert is undersized for today's standards and the watershed.
5	Sta. 1+093 Roll No. 570-00700 (Secondary Access Culvert)	N/A	New Culvert Location
6	Sta. 1+142 Roll No. 570-00710	19m x 600mm dia. CSP with a 600x600 CB	Due to the amount of water and sediment in the drain it the culvert could not be inspected. This culvert is undersized for today's standards and the watershed.
7	Sta. 1+525 Roll No. 570-00800	N/A	New Culvert Location

Culvert No. 4 and No. 6 are undersized for the drain based on today's standards. They should be inspected by the Drainage Superintendent after maintenance of the channel is completed to determine the condition of each culvert. Our appointment did not include addressing all culverts for replacement under this report.

In the future, if any additional culverts, other than the ones addressed in this Report, require replacement, a new Engineer's Report is required under Section 78 of the *Drainage Act*.

Public Information Centre Meeting

R. Dobbin Engineering submitted a Draft Engineer's Report dated February 19, 2026. A Public Information Centre Meeting was held on March 11, 2026 to discuss the contents of the Report.

The following were present at the meeting:

- David Moores (R. Dobbin Engineering)
- Lu-Ann Marentette (Town of Kingsville)
- Clare Janisse (Town of Kingsville)
- Tom DiPerko (Landowner)
- Maryann Sladic (Landowner)

The following is a brief summary of the meeting:

- The Drainage Superintendent provided introductions and gave a brief explanation of the project.
- An overview of the *Drainage Act* was provided and it was explained to the landowners in attendance how the project will affect them and more details of the project was provided.
- The Owner of Roll No. 570-00701 asked why his culvert was not assessed as part of this Report. The Drainage Superintendent advised him that his property fronts onto the roadside ditch along Cameron Sideroad, not the municipal drain. The Owner also asked about the cleanout of the roadside ditch. The Drainage Superintendent confirmed that the ditch in front of his property will not be cleaned out as it is a roadside ditch and that she had done that a couple of years ago. The Drainage Superintendent explained that the ditch behind his property is what we are discussing at this meeting, as that is the municipal drain.
- The Owner of Roll No. 570-01400 asked how much her assessment would be for this work. R. Dobbin Engineering outlined that the estimate in the Report is approximately \$26.00. The Town advised her that any amount under \$250.00 is added directly to the tax roll.
- Both residents inquired about the road closure by MTO and were advised that all closures due to the highway widening are up to the MTO, not the Town of Kingsville.
- It was clarified that for this project, the road will not be closed; one lane will be closed to allow for the equipment.
- The Owner of Roll No. 580-06600 reached out to the Drainage Superintendent and Engineer prior to the meeting as he could not attend in person. The Owner had questions related to the proposed work and assessment. Answers were provided to the Owner via email.
- There was discussion in detail about the proposed work and estimated costs.

- No other requests or revisions were received for changes to the report.

### Recommendations

It is therefore recommended that the following work be carried out:

1. Culvert No. 2 at Station 0+393 shall be installed.
2. Culvert No. 3 at Station 0+840 shall removed from the drain.
3. Culvert No. 5 at Station 1+093 shall be installed.
4. Culvert No. 7 at Station 1+525 shall be installed.
5. A new drain profile and updated maintenance schedule for the open channel shall be developed.

### Design

All agricultural and residential culverts have been designed to meet a 1 in 5 year storm event.

### Estimate of Cost

It is recommended that the work be carried out in accordance with the accompanying Specification of Work and the Profile, which form part of this Report. There has been prepared an Estimate of Cost in the amount of \$130,560.00 including the cost of engineering. A Plan has been prepared showing the location of the work and the approximate drainage area. An estimate for tendering, inspection, and contract administration has been provided. This estimate includes attendance at the Public Information Session, the Meeting to Consider and the Court of Revision, but does not include any appearances before appeal bodies beyond the Court of Revision.

### Assessment

As per Section 21 of the *Drainage Act*, the Engineer in his report shall assess for benefit and outlet for each parcel of land and road liable for assessment.

Lands, roads, buildings, utilities, or other structures that are increased in value or are more easily maintained as a result of the construction, improvement, maintenance, or repair of a drainage works may be assessed for benefit. (Section 22)

Lands and roads that use a drainage works as an outlet, or for which, when the drainage works is constructed or improved, an improved outlet is provided either directly or indirectly through the medium of any other drainage works or of a swale, ravine, creek, or watercourse may be assessed for outlet. The assessment for outlet shall be based on the volume and rate of flow of the water artificially caused to flow into the drainage works from the lands and roads liable for such assessments. (Section 23)

The Engineer may assess for special benefit any lands for which special benefits have been provided by the drainage works. (Section 24)

A Schedule of Assessment for the lands and roads affected by the work and therefore liable for the cost thereof is attached as per the *Drainage Act*. Also, assessments may be made against any public utility or road authority, as per Section 26 of the *Drainage Act*, for any increased cost for the removal or relocation of any of its facilities and plant that may be necessitated by the construction or maintenance of the drainage works. Items to be assessed under Section 26, as specified, shall be tendered separately with the actual cost plus a portion of the engineering (25% of the construction cost). The estimated cost of the drainage works has been assessed in the following manner:

1. Culvert No. 2, No. 3, and No. 5 have been assessed 100% of the cost as a benefit assessment to Roll No. 570-00700.
2. Culvert No. 7 have been assessed 100% of the cost as a benefit assessment to Roll. No. 570-00800.
3. The updated profile and maintenance schedule has been assessed as an outlet assessment against lands and road based on equivalent hectares.

All final costs included in the cost estimate of this report shall be pro-rated based on the Schedule of Assessment. Any additional costs shall be assessed in a manner as determined by the Engineer.

#### Allowances

Under Section 29 of the *Drainage Act*, the Engineer in his report shall estimate and allow in money to the Owner of any land that it is necessary to use for the construction or improvement of a drainage works or for the disposal of material removed from a drainage works. This shall be considered an allowance for right of way.

Under Section 30 of the *Drainage Act*, the Engineer shall determine the amount to be paid to persons entitled thereto to damage, if any, to ornamental trees, fences, land, and

crops occasioned by the disposal of material removed from a drainage works. This shall be considered an allowance for damages.

In this report, no allowances have been made.

#### Approvals and Drain Classification

The Ash-Cameron Drain is currently classified as a class “F” drain along its length.

Class “F” drains are intermittent or ephemeral (dry for more than three consecutive months). The proposed work will require a permit from the Essex Region Conservation Authority. No authorization is required from Fisheries and Oceans if the work is completed in the dry and the Culvert BMP is followed. No works can take place until all approvals are received.

The proposed improvements and culvert replacements will have very little effect on the drainage works if carried out during low flows in the channel.

#### Restrictions

No trees or shrubs shall be planted nor shall permanent structures be erected within 10 metres of either side of the proposed drain without prior written permission of Council. If trees are planted that interfere with access for future maintenance of the drainage works, they shall be removed at the expense of the Owner.

Attention is also drawn to Sections 80 and 82 of the *Drainage Act* that refer to the obstruction of a drainage works.

#### Agricultural Grant

It is recommended that application for subsidy be made for eligible farm tax class agricultural properties by the Township. The Ontario Ministry of Agricultural, Food, and Agribusiness offers the “Agricultural Drainage Infrastructure Program (ADIP)”. This program will pay 1/3 of any eligible agricultural assessments that meet the criteria contained within the policy.

Any assessments against non agricultural properties are shown separately in the Schedule of Assessment.

Maintenance

The open channel shall be maintained and repaired in accordance with the specifications and drawings contained within this report and assessed out using the attached Schedule of Maintenance.

Culvert No. 2 and No. 5 are additional culverts to the property. Therefore, they shall be maintained and repaired using the specifications contained within this report and assessed out with 100% of the cost applied as a benefit assessment to Roll No. 570-00700.

Culvert No. 7 shall be maintained and repaired using the specifications contained within this report and assessed out with 50% of the cost applied as a benefit assessment to Roll No. 570-00800 and 50% of the cost assessed to upstream lands as an outlet assessment as shown in the table on the next page:

Roll No.	Benefit Assessment %	Outlet Assessment %
570-00800	50%	25%
570-01601		4%
570-01700		3%
570-01800		3%
570-01900		8%
570-01901		7%

Any extra cost as a result of the location of underground utilities shall be assessed 100% to the utility as per Section 26 of the *Drainage Act*.

These above conditions will apply unless otherwise altered under the provisions of the *Drainage Act*.

All of the above is submitted for your consideration.

Yours truly,

Report Prepared By:

David Moores, C.E.T.



Report Approved By:

Josh Warner, P.Eng.

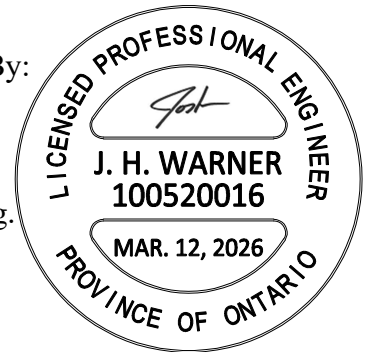



Ash-Cameron Drain  
Town of Kingsville  
March 12, 2026

Page 1 of 2

### Estimate of Cost

To remove one culvert and install three new culverts in Lot 275, Concession South Talbot Road.

	Quantity	Unit	Unit Cost	Total
<b>Culvert No. 2 - Station 0+393</b>				
Supply and Install 1050mmø Santite HP	24	m	1,000.00	24,000.00
Open Channel Excavation in the Vicinity of the Proposed Culvert including Disposal (30m)	1	LS	2,000.00	2,000.00
Supply and Install Clearstone Bedding	20	t	45.00	900.00
Supply and Install Granular "B" Type II Backfill	200	t	35.00	7,000.00
Supply and Install Granular "A" Driveway	40	t	40.00	1,600.00
Supply and Install Rip Rap Endwalls	30	t	85.00	2,550.00
Environmental Considerations (Silt Fence)	1	LS	200.00	200.00
				<u>38,250.00</u>
<b>Culvert No. 3 - Station 0+840</b>				
Remove and Dispose Existing Culvert, endwalls, and excess material	1	LS	1,000.00	1,000.00
Bottom Cleanout including Drain Bank Resloping to Match Existing (6m)	1	LS	1,000.00	1,000.00
Supply and Installation of Straw Matting and Grass Seed on Drain Banks	1	LS	1,000.00	1,000.00
Environmental Considerations (Silt Fence)	1	LS	200.00	200.00
				<u>3,200.00</u>
<b>Culvert No. 5 - Station 1+093</b>				
Supply and Installation of 900mmø HDPE	24	m	750.00	18,000.00
Open Channel Excavation in the Vicinity of the Proposed Culvert including Disposal (30m)	1	LS	2,000.00	2,000.00
Supply and Install Clearstone Bedding	20	t	45.00	900.00
Supply and Install Granular "B" Type II Backfill	200	t	35.00	7,000.00
Supply and Install Granular "A" Driveway	40	t	40.00	1,600.00
Supply Rip Rap Endwalls	30	t	85.00	2,550.00
Environmental Considerations (Silt Fence)	1	LS	200.00	200.00
				<u>32,250.00</u>

	Quantity	Unit	Unit Cost	Total
Culvert No. 7 - Station 1+525				
Supply and Installation of 750mmø HDPE	12	m	650.00	7,800.00
Open Channel Excavation in the Vicinity of the Proposed Culvert including Levelling (18m)	1	LS	1,200.00	1,200.00
Supply and Install Clearstone Bedding	20	t	45.00	900.00
Supply and Install Granular "A" Backfill & Driveway	140	t	40.00	5,600.00
Supply Rip Rap Endwalls	20	t	85.00	1,700.00
Environmental Considerations (Silt Fence)	1	LS	200.00	200.00
				<u>17,400.00</u>
Contingency				<u>4,700.00</u>
				Sub Total 95,800.00
				Allowances -
				Engineering 18,220.00
				Update Maintenance Schedule & Drain Profile 3,500.00
				Estimate for Tendering, Inspection & Contract Admin. 10,000.00
				ERCA Fees (Permit) <u>800.00</u>
				Total Estimate excluding HST 128,320.00
				Non-Recoverable HST (1.76%) <u>2,240.00</u>
				<b>Total Estimate \$130,560.00</b>

Ash-Cameron Drain  
 Town of Kingsville  
 March 12, 2026

**SCHEDULE OF ASSESSMENT**

To remove one culvert and install three new culverts in Lot 275, Concession South Talbot Road.

Conc.	Lot or Part	Affected Hect.	Roll No.	Benefit (\$)	Outlet (\$)	Total (\$)
<b>Agricultural Lands (Grantable)</b>						
STR	pt. Lot 275	14.52	570-00700	101,520.00	1,581.00	103,101.00
	pt. Lot 276	5.34	580-06600	-	388.00	388.00
	Total Agricultural Lands			101,520.00	1,969.00	103,489.00
<b>Non-Agricultural Lands (Non-Grantable)</b>						
STR	pt. Lot 275	0.37	570-00701	-	54.00	54.00
	pt. Lot 275	0.31	570-00710	-	45.00	45.00
	pt. Lot 275	3.06	570-00800	25,540.00	65.00	25,605.00
	pt. Lot 275	0.45	570-00810	-	65.00	65.00
	pt. Lot 275	0.45	570-00820	-	65.00	65.00
	pt. Lot 275	0.45	570-00830	-	90.00	90.00
	pt. Lot 275	0.62	570-00840	-	13.00	13.00
	pt. Lot 275	0.09	570-00900	-	13.00	13.00
	pt. Lot 275	0.09	570-01000	-	13.00	13.00
	pt. Lot 275	0.10	570-01100	-	15.00	15.00
	pt. Lot 275	0.10	570-01200	-	15.00	15.00
	pt. Lot 275	0.24	570-01300	-	35.00	35.00
	pt. Lot 275	0.18	570-01400	-	26.00	26.00
	pt. Lot 275	0.34	570-01500	-	49.00	49.00

Conc.	Lot or Part	Affected Hect.	Roll No.	Benefit (\$)	Outlet (\$)	Total (\$)
STR	pt. Lot 275	0.25	570-01600	-	36.00	36.00
	pt. Lot 275	0.30	570-01601	-	44.00	44.00
	pt. Lot 275	0.23	570-01700	-	33.00	33.00
	pt. Lot 275	0.25	570-01800	-	36.00	36.00
	pt. Lot 275	0.56	570-01900	-	81.00	81.00
	pt. Lot 275	0.39	570-01901	-	57.00	57.00
	pt. Lot 276	0.01	580-06700	-	1.00	1.00
Total Non-Agricultural Lands				25,540.00	851.00	26,391.00
<b>Public Lands</b>						
	South Talbot Road	0.15	Town of Kingsville	-	33.00	33.00
	Cameron Sideroad	1.75	Town of Kingsville	-	508.00	508.00
	County Road 34	0.48	County of Essex	-	139.00	139.00
Total Public Lands				-	680.00	680.00
Total Agricultural Lands				101,520.00	1,969.00	103,489.00
Total Non-Agricultural Lands				25,540.00	851.00	26,391.00
Total Public Lands				-	680.00	680.00
<b>Total Area</b>		<b>31.08</b>	<b>Total Assessment</b>	<b>127,060.00</b>	<b>3,500.00</b>	<b>130,560.00</b>

Ash-Cameron Drain  
 Town of Kingsville  
 February 19, 2026

**SCHEDULE OF MAINTENANCE**

To maintain the open channel.

Conc.	Lot or Part	Affected Hectares	Roll No.	Benefit (\$)	Outlet (\$)	Total (\$)
<b>Agricultural Lands (Grantable)</b>						
STR	pt. Lot 275	14.52	570-00700	2,528.00	718.00	3,246.00
	pt. Lot 276	5.34	580-06600	-	316.00	316.00
			<b>Total Agricultural Lands</b>	<b>2,528.00</b>	<b>1,034.00</b>	<b>3,562.00</b>
<b>Non-Agricultural Lands (Non-Grantable)</b>						
STR	pt. Lot 275	0.37	570-00701	136.00	66.00	202.00
	pt. Lot 275	0.31	570-00710	112.00	55.00	167.00
	pt. Lot 275	3.06	570-00800	1,264.00	939.00	2,203.00
	pt. Lot 275	0.45	570-00810	164.00	87.00	251.00
	pt. Lot 275	0.45	570-00820	164.00	89.00	253.00
	pt. Lot 275	0.45	570-00830	164.00	90.00	254.00
	pt. Lot 275	0.62	570-00840	227.00	126.00	353.00
	pt. Lot 275	0.09	570-00900	-	17.00	17.00
	pt. Lot 275	0.09	570-01000	-	17.00	17.00
	pt. Lot 275	0.10	570-01100	-	17.00	17.00
	pt. Lot 275	0.10	570-01200	-	17.00	17.00
	pt. Lot 275	0.24	570-01300	-	51.00	51.00
	pt. Lot 275	0.18	570-01400	-	39.00	39.00
	pt. Lot 275	0.34	570-01500	-	71.00	71.00
	pt. Lot 275	0.25	570-01600	91.00	52.00	143.00

Item K.1
----------

Conc.	Lot or Part	Affected Hecatares	Roll No.	Benefit (\$)	Outlet (\$)	Total (\$)
STR	pt. Lot 275	0.30	570-01601	111.00	64.00	175.00
	pt. Lot 275	0.23	570-01700	-	47.00	47.00
	pt. Lot 275	0.25	570-01800	-	51.00	51.00
	pt. Lot 275	0.56	570-01900	-	122.00	122.00
	pt. Lot 275	0.39	570-01901	-	80.00	80.00
	pt. Lot 276	0.01	580-06700	-	5.00	5.00
Total Non-Agricultural Lands				2,433.00	2,102.00	4,535.00
<b>Public Lands</b>						
	South Talbot Road	0.15	Town of Kingsville	83.00	34.00	117.00
	Cameron Sideroad	1.75	Town of Kingsville	956.00	601.00	1,557.00
	County Road 34	0.48	County of Essex	-	229.00	229.00
Total Public Lands				1,039.00	864.00	1,903.00
<b>Total Area</b>		<b>31.08</b>	<b>Total Maintenance Assessment</b>	<b>6,000.00</b>	<b>4,000.00</b>	<b>10,000.00</b>

Ash-Cameron Drain  
Town of Kingsville  
March 12, 2026

## **SPECIFICATION OF WORK**

### **1. Scope of Work**

The work includes the installation of three culverts and the removal of one culvert. All works are located in Lot 275, Concession South Talbot Road, in the Town of Kingsville.

### **2. General**

Each tenderer must inspect the site prior to submitting their tender and satisfy themselves by personal examination as to the local conditions that may be encountered during this project. The tenderer shall make allowance in the tender for any difficulties which they may encounter. Quantities or any information supplied by the Engineer is not guaranteed and is for reference only.

All work and materials shall be to the satisfaction of the Drainage Superintendent who may vary these specifications as to minor details but in no way decrease the proposed capacity of the drain.

The Contractor shall be responsible for the notification of all utilities prior to the start of construction.

### **3. Plans and Specifications**

These specifications shall apply and be part of the contract. This specification of work shall take precedence over all plans and general conditions pertaining to the contract. The Contractor shall provide all labour, equipment, and supervision necessary to complete the work as shown in the plans and described in these specifications. Any work not described in these specifications shall be completed according to the Ontario Provincial Standard Specifications and Standard Drawings.

#### **4. Health and Safety**

The Contractor at all times shall be responsible for health and safety on the worksite including ensuring that all employees wear suitable personal protective equipment including safety boots and hard hats.

The Contractor shall be responsible for traffic control as per the Ontario Traffic Manual Book 7 – Temporary Conditions (latest revision) when working on public road allowances. A copy of the traffic control plan shall be kept on site at all times. The Contractor shall maintain suitable barricades, warning lights, and temporary traffic notices, at his expense, in their proper position to protect the public both day and night. Flagmen are the responsibility of the Contractor when working on the road allowance and when entering or exiting a worksite onto a roadway.

The Contractor shall be responsible to ensure that all procedures are followed under the Occupational Health and Safety Act to ensure that work sites are safe and that accidents are prevented. In the event of a serious or recurring problem, a notice of noncompliance will be issued. The Contractor will be responsible for reacting immediately to any deficiency and correcting any potential health and safety risk. Continuous disregard for any requirement of the Occupational Health and Safety Act could be cause for the issuance of a stop work order or even termination of the contract.

The Contractor shall also ensure that only competent workers are employed on-site and that appropriate training and certification is supplied to all employees.

#### **5. Workplace Safety and Insurance Board**

The Contractor hereby certifies that all employees and officers working on the project are covered by benefits provided by the Contractor. The WSIB clearance certificate must be furnished prior to the execution of the Contract and updated every 60 days.

#### **6. Weather Conditions**

Work shall be carried out under this Report and completed within the agreed upon Schedule as permitted by weather. The Engineer or the Drainage Superintendent reserves the right to restrict construction and access to the site based on the weather and ground conditions.

## **7. Access and Working Area**

Access to the drain for the replacement of the culverts shall be from Cameron Sideroad. Access for Culvert No. 7 shall be from Cameron Sideroad through the property with Roll No. 570-00800. Access shall be restricted to a width of 6 meters. The working area at each culvert shall extend 10 meters on either side of the culvert within the same property or road.

Access to the drain for channel maintenance shall be from Cameron Sideroad using existing culverts and laneways. The working corridor shall be restricted to 15 meters measured for the top of the drain bank from the side the excavator is working from.

Then working area shall be as follows:

0+000 to 0+171 – North Side

0+171 to 1+168 – East Side

1+168 to 1+233 – North Side

1+233 to 1+765 – East Side and South Side

If a landowner owns property on both sides of the drain, then the working corridor can be either side, based on approval of the landowner.

The working side of the drain can be switched to the road side between Station 0+000 to 1+168 at the discretion of the Drainage Superintendent.

## **8. Access Culverts**

This item shall apply to the construction of the three new culverts.

Culvert No. 2 – 24.0 metres of 1050 mm diameter Sanitite HP pipe with rip rap endwalls, full granular backfill, and a gravel drive.

Culvert No. 5 – 24.0 metres of 900 mm diameter HDPE pipe with rip rap endwalls, full granular backfill, and a gravel drive.

Culvert No. 7 – 12.0 metres of 750 mm diameter HDPE pipe with rip rap endwalls, full granular backfill, and a gravel drive.

The pipe material shall be Sanitite HP pipe or HDPE pipe as specified on the plan and profile with a minimum 320 kPa pipe stiffness and be CSA certified with bell and spigot joints.

The proposed culverts shall be installed as shown on the attached plan and profile. The exact location will be determined in the field at the time of construction. The culvert shall be set with the invert 10% (minimum 150mm) below the proposed channel bottom elevation and to grade shown on the profile.

The culvert may be moved upstream or downstream as necessary to avoid existing tile outlets. If they cannot be avoided, the pipes shall be extended downstream of the proposed culvert and shall be done with non-perforated HDPE agricultural tubing with a manufactured coupling, elbow and rodent grate. Any tile outlets extended as a result of extra length requested by an owner shall be extended at the owner's expense.

Prior to installing the culverts, the drain bottom shall be cleaned out and the excavated material shall be disposed offsite at a location determined by the Contractor. This excavation includes 3 meters upstream and downstream of the proposed culvert. The topsoil from the drain sideslopes and boulevard shall be removed and disposed offsite as well.

The bottom of the excavation shall be excavated to the required depth with any over excavation backfilled with clearstone. When the pipe has been installed to the proper grade and depth, the excavation shall be backfilled with clearstone from 100mm below the bottom of the pipe up to the springline of the pipe. Care shall be taken to ensure that the backfill on either side of the culvert does not differ by more than 300 mm so that the pipe is not displaced. The culverts shall be backfilled from the springline to 300mm of finished grade with granular "B" type 2 or 100% crushed granular "A". The top 300mm for shall be backfilled with compacted 100% crushed granular "A" material to finished grade, including the boulevard between the drain and edge of road.

All backfill shall be free from deleterious material. All granular material shall be mechanically compacted to 98% modified standard proctor density. All backfill material above the springline shall be mechanically compacted using appropriate compaction equipment.

The culvert shall be installed as per manufacture recommendations with a minimum cover of 300mm over top of the pipe measured from the top of the culvert to finished grade. It shall be the responsibility of the Contractor to ensure the culvert has no traffic on it until the minimum cover is met.

End protection shall be rip rap quarry stone placed with a minimum slope of 1.5:1. The rip rap shall consist of 150 mm x 300 mm quarry stone or approved equal. The area to receive the rip rap shall be graded to a depth of 450mm below finished grade. Filter fabric (Terrafix 250R or approved equal) shall then be placed with any joints overlapped

a minimum of 600mm. The quarry stone shall then be placed with the smaller pieces placed in the gaps and voids to give it a uniform appearance.

### **9. Culvert Removal – Sta 0+840**

This item shall apply to the removal of the existing culvert located at Sta. 0+840.

The culvert, endwalls, and excess material shall be removed from the drain and disposed of offsite at a location determined by the Contractor.

The drain banks shall be reshaped to match the existing sideslopes. The sideslopes shall be seeded and straw erosion matting (S150) shall be installed on the exposed drain banks as per manufactured specifications.

### **10. Open Channel Excavation (Future)**

The open channel shall be excavated to the grade line and elevations shown on the attached profile. A laser or similar approved device with a labourer on-site to ensure correctness of grade and to confirm location of tile ends. The sediment shall be removed leaving a rounded bottom with the intent not to undercut the existing sideslopes.

The excavated material shall be cast at least 1.5 metres clear of the top of the bank on agricultural lands with the excavated material spread back and levelled to a maximum depth of 150 mm and left in a cultivated condition.

Excavated material shall be hauled away from any lawn, garden, orchard, parking, roadway, or driveway areas by the Contractor at its expense. All work at the disposal site shall be established between the Contractor and site owner. The Contractor shall be responsible for obtaining any permits required and shall provide copies of the same to the Town.

Excavated material shall not be placed in low runs or swales outletting surface water to the channel. Stones and large branches shall be removed and disposed offsite and shall not be buried when the excavated material is spread.

### **11. Brushing (Future)**

All brush, trees, woody vegetation, cattails, phragmites, etc. shall be removed from the sideslopes of the existing channel within 1.5 metres of the top of the bank. Other brush and trees may be removed from the side the equipment is operating to allow access for the equipment. Trees and brush in the channel bottom shall be removed in their entirety

including stumps and disposed offsite. Trees and brush on the sideslopes shall be close cut.

It is recommended that a mechanical grinder attached to an excavator be used for the removal of brush and trees. Any brush and trees too large to grind shall be close cut with the logs and brush disposed offsite by the Contractor. The Contractor shall be responsible for obtaining all necessary permits for any disposal sites.

Certain trees may be left in place at the direction of the Drainage Superintendent. Any trees to be salvaged by the individual landowners shall be removed by the landowners with all resulting brush and branches cleaned up prior to the start of construction. If the Contractor agrees to remove any trees and set them aside for a landowner, the landowner will be responsible for any cleanup as above.

## **12. Silt Fence**

The Contractor shall maintain a dry working area during construction by installing a silt fence downstream of the work areas. Under this Report, there are four working areas. Silt fences shall be installed downstream of Culvert No. 2, Culvert No. 3, Culvert No. 5, and Culvert No. 7 prior to commencing any work.

The silt fence shall consist of filter fabric or manufactured silt fence supported with posts (OPSD 219.110). The silt fence shall remain in place until construction is complete. Any sediment that has collected upstream of the silt fence shall be removed prior to the removal of the silt fence.

The location of the silt fence can be changed by the Engineer or Drainage Superintendent.

## **13. Environmental Considerations**

The Contractor shall take care to adhere to the following considerations.

- Operate machinery in a manner that minimizes disturbance to the banks of the watercourse.
- Erosion and sediment control measures must be installed prior to construction to prevent sediment from entering the water body.

- All granular and erosion control materials shall be stockpiled a minimum of 1.5 metres from the top of the bank or excavation. Material shall not be placed in surface water runs or open inlets that enter the channel.
- All activities, including maintenance procedures, shall be controlled to prevent the entry of petroleum products, debris, rubble, concrete, or other deleterious substances into the water. Vehicle and equipment refuelling and maintenance shall be conducted away from the channel, any surface water runs, or open inlets. All waste materials shall be stockpiled well back from the top of the bank and all surface water runs and open inlets that enter the drain.
- When possible, all construction within the open channel shall be carried out during periods of low flow or in dry conditions.
- The Culvert BMP provided in the Guidance Document for maintaining and repairing municipal drains shall be used to isolate the working area. This shall be included in the tender document.
- The Contractor shall conduct regular inspections and maintain erosion and sediment control measures and structures during the course of construction.
- The Contractor shall repair erosion and sediment control measures and structures if damage occurs.
- The Contractor shall remove non-biodegradable erosion and sediment control materials once site is stabilized.
- The Contractor shall remove all construction materials from site upon project completion.

#### **14. Benchmarks**

The benchmarks are based on geodetic elevations. Elevations are available at the culvert locations shown on the profile drawings. Where these elevations are on existing structures to be replaced, they shall be moved prior to the removal of the culverts. Prior to construction, it is the responsibility of the Contractor to perform a benchmark loop and report any discrepancies to the Engineer or Drainage Superintendent.



LOT 276

LOT 275

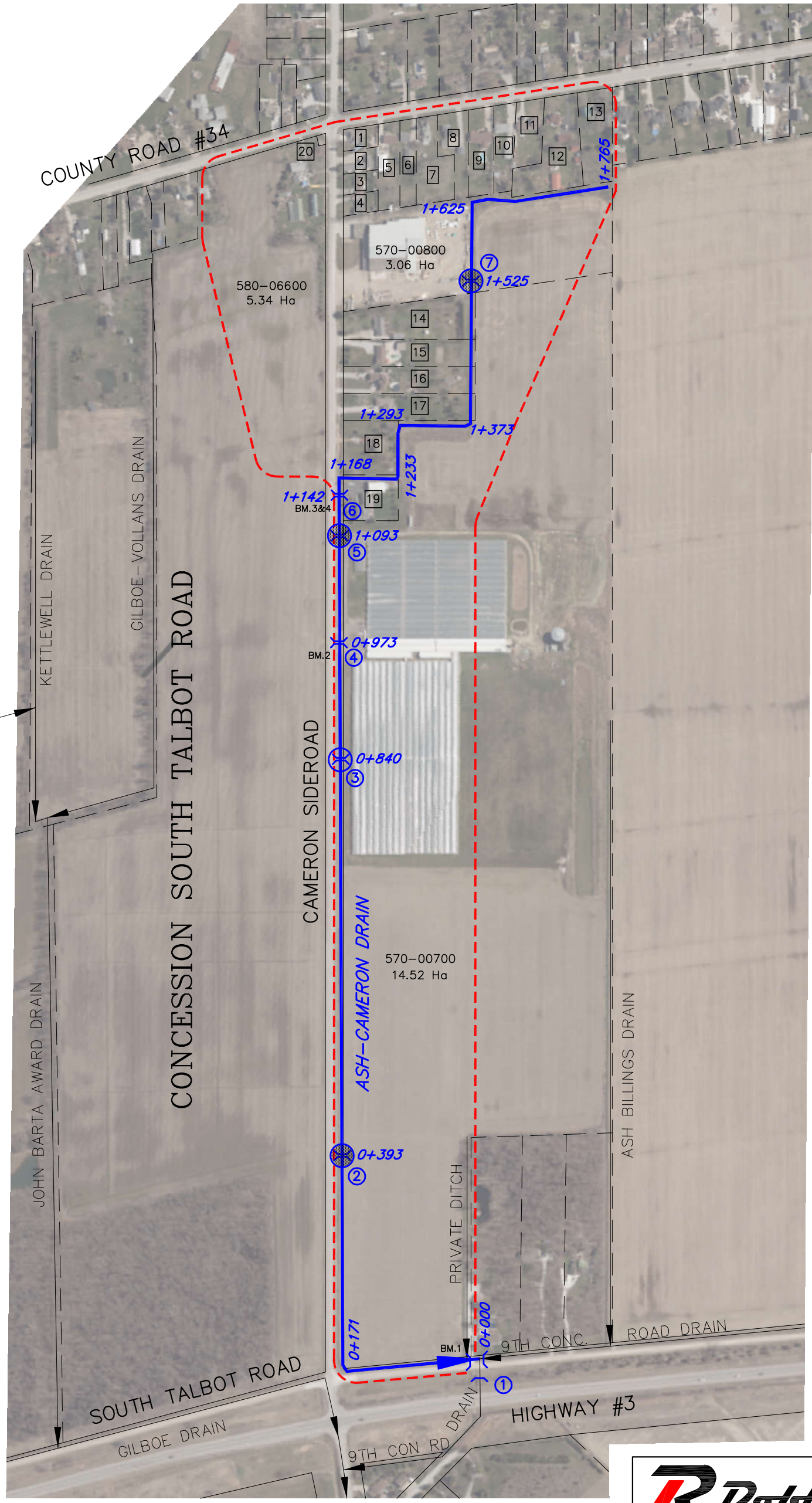
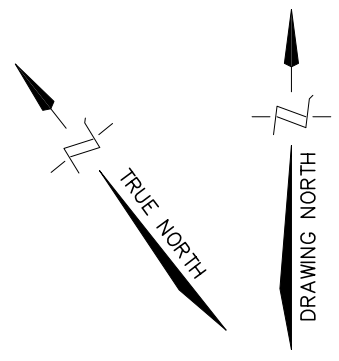

- |                          |                          |
|--------------------------|--------------------------|
| 1. 570-01200<br>0.10 Ha  | 11. 570-01800<br>0.25 Ha |
| 2. 570-01100<br>0.10 Ha  | 12. 570-01900<br>0.56 Ha |
| 3. 570-01000<br>0.09 Ha  | 13. 570-01901<br>0.39 Ha |
| 4. 570-00900<br>0.09 Ha  | 14. 570-00840<br>0.62 Ha |
| 5. 570-01300<br>0.24 Ha  | 15. 570-00830<br>0.45 Ha |
| 6. 570-01400<br>0.18 Ha  | 16. 570-00820<br>0.45 Ha |
| 7. 570-01500<br>0.34 Ha  | 17. 570-00810<br>0.45 Ha |
| 8. 570-01600<br>0.25 Ha  | 18. 570-00701<br>0.37 Ha |
| 9. 570-01601<br>0.30 Ha  | 19. 570-00710<br>0.31 Ha |
| 10. 570-01700<br>0.23 Ha | 20. 580-06700<br>0.01 Ha |



LEGEND

- ASH-CAMERON DRAIN
- MUNICIPAL DRAIN
- DRAINAGE AREA
- CULVERT LOCATION
- EXISTING CULVERT
- PROPOSED NEW CULVERT
- REMOVE CULVERT

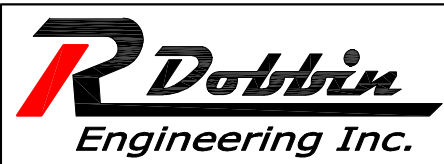

4218 Oil Heritage Road  
Petrolia Ontario, N0N 1R0  
Phone: (519) 882-0032 Fax: (519) 882-2233

DRAWING NAME:  
Ash-Cameron Drain Plan

PROJECT No.  
2025-1758

APPROVED	NO.	REVISIONS	DATE	BY
J. WARNER				
CHECKED	1	FINAL REPORT	MAR. 12, 2026	DM
D. MOORES				
DRAWN	SCALE: 1:5000			
C. SAUNDERS	0 50 100 150m			

**TOWN of KINGSVILLE**  
**ASH - CAMERON DRAIN**  
**PLAN**

**1**  
**OF 7**

Last Updated: March 12, 2026

# GENERAL NOTES

- BENCHMARK No. 1 ELEV. 194.21  
TOP OF WEST END OF 1500mm $\phi$  CSP ON NORTH SIDE OF SOUTH TALBOT RD AT STA. 0+013.
- BENCHMARKS TO BE TRANSFER FROM EXISTING CULVERT TOP TO NEW CULVERT TOP AFTER REPLACEMENT.
- NEW BENCHMARK TO BE PLACED ON CULVERT No.2 TOP NORTH END, ONCE INSTALLATION IS COMPLETED.

3. UPPER NUMBERS ARE DEPTH FROM TOP OF BANK TO FUTURE CHANNEL BOTTOM.

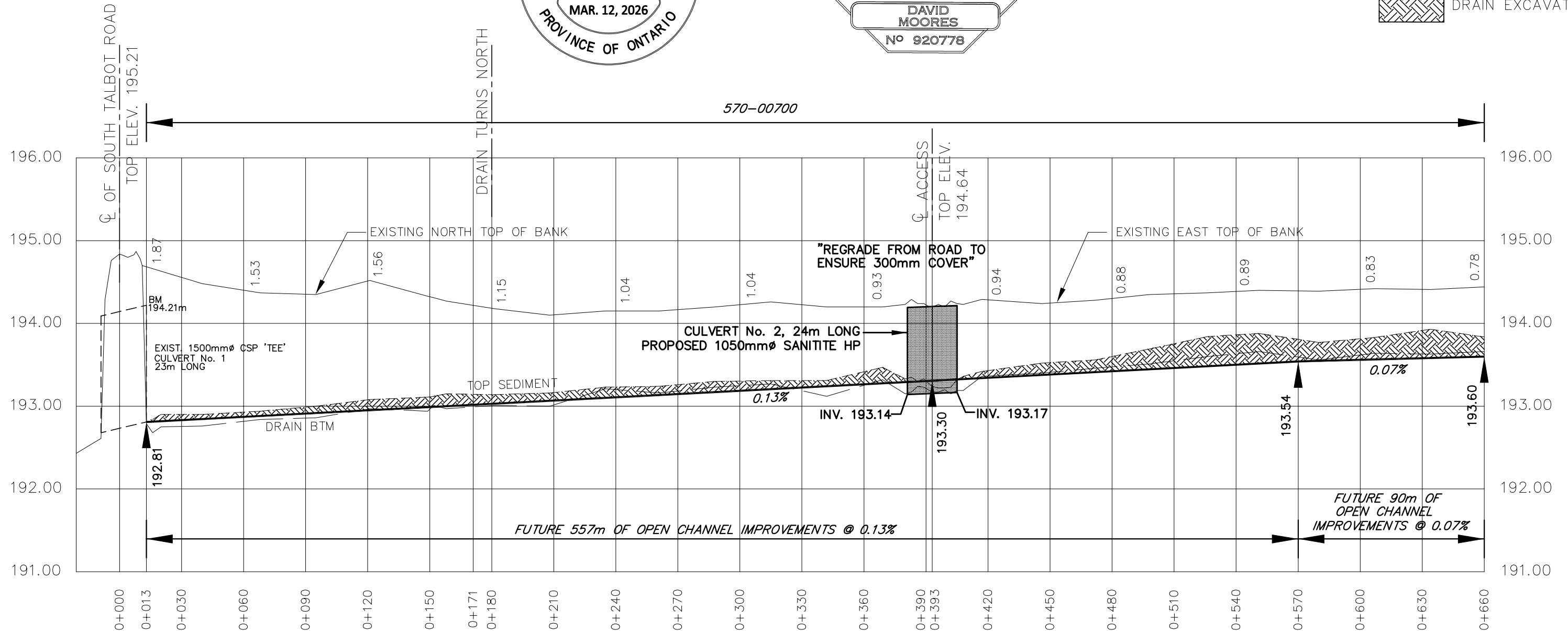
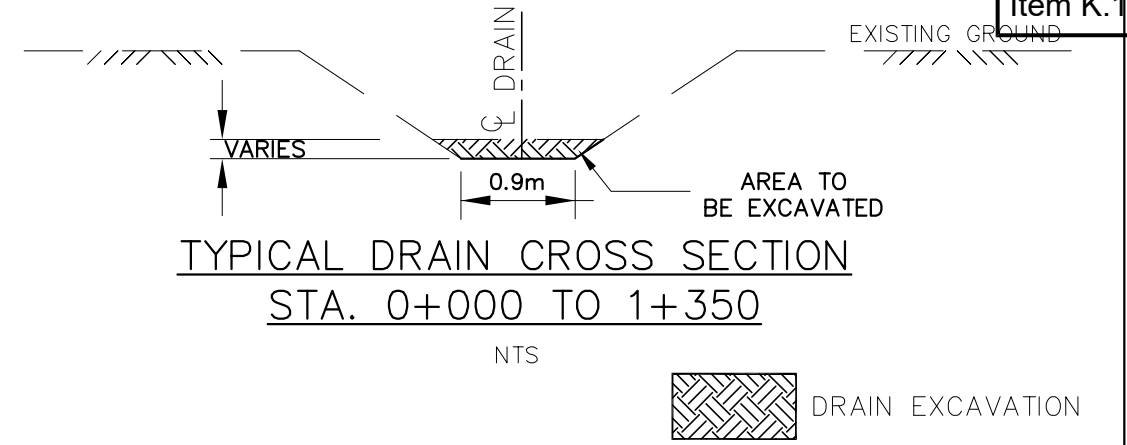
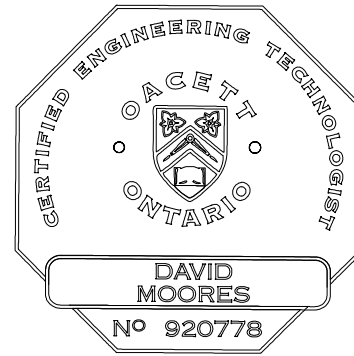
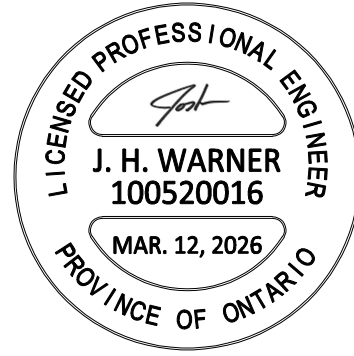

4218 Oil Heritage Road  
Petrolia Ontario, N0N 1R0  
Phone: (519) 882-0032 Fax: (519) 882-2233

APPROVED	NO.	REVISIONS	DATE	BY
J. WARNER				
CHECKED	1	FINAL REPORT	MAR. 12, 2026	DM
D. MOORES				
DRAWN				
C. SAUNDERS				

SCALE: 1:2,000

0 20 40 60m

## TOWN of KINGSVILLE

### ASH - CAMERON DRAIN PROFILE

2  
OF 7

**GENERAL NOTES**

- 1. BENCHMARK No. 2 ELEV. 194.70  
TOP OF SOUTH END OF EXISTING  
600Ø CSP AT CULVERT No. 4 AT  
STATION 0+973  
BENCHMARK No. 3 ELEV. 194.96  
TOP OF SOUTH END OF EXISTING  
600Ø CSP AT CULVERT No. 6 AT  
STATION 1+142  
BENCHMARK No. 4 ELEV. 195.90  
TOP OF EXISTING CB AT STA. 1+142.

- 3. NEW BENCHMARK TO BE PLACED ON CULVERT No.5 TOP  
NORTH END, ONCE INSTALLATION IS COMPLETED.
- 4. UPPER NUMBERS ARE DEPTH FROM TOP OF  
BANK TO FUTURE CHANNEL BOTTOM.

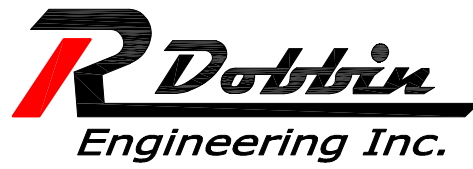
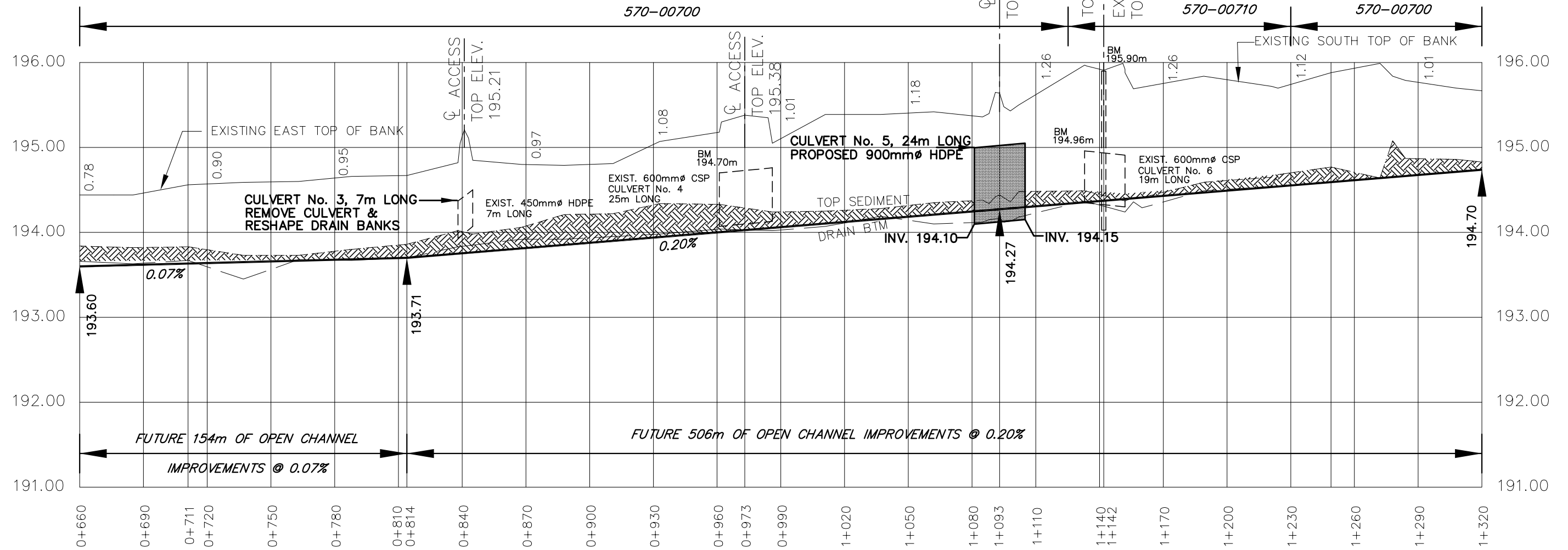
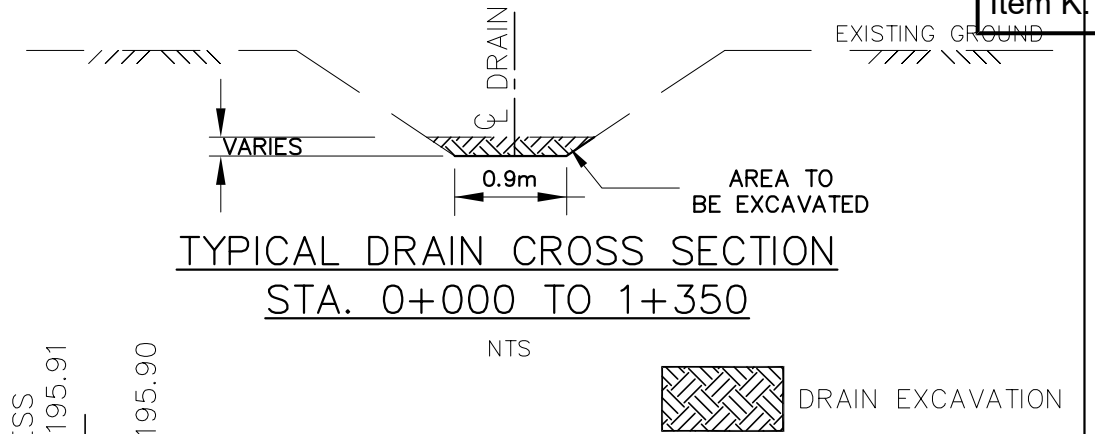
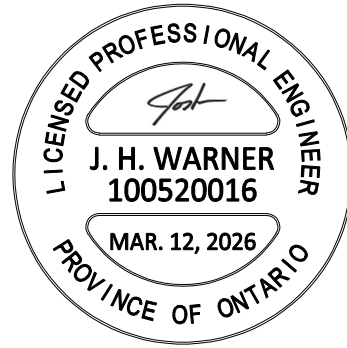

4218 Oil Heritage Road  
Petrolia Ontario, N0N 1R0  
Phone: (519) 882-0032 Fax: (519) 882-2233

APPROVED	NO.	REVISIONS	DATE	BY
J. WARNER				
CHECKED D. MOORES	1	FINAL REPORT	MAR. 12, 2026	DM
DRAWN C. SAUNDERS				

SCALE: 1:2,000  
0 20 40 60m

**TOWN of KINGSVILLE**  
**ASH - CAMERON DRAIN**  
**PROFILE**

**GENERAL NOTES**

1. R. DOBBIN ENGINEERING INC. TO PROVIDE BENCHMARK AT TIME OF CONSTRUCTION IN THE VICINITY OF PROPOSED CULVERT No. 7.
2. NEW BENCHMARK TO BE PLACED ON CULVERT No.7 TOP ONCE INSTALL IS COMPLETED.
3. UPPER NUMBERS ARE DEPTH FROM TOP OF BANK TO FUTURE CHANNEL BOTTOM.

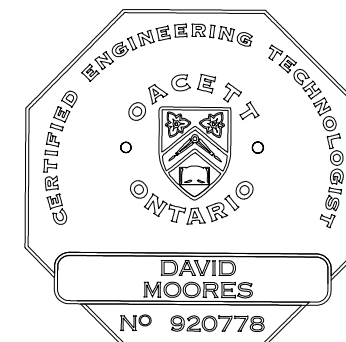
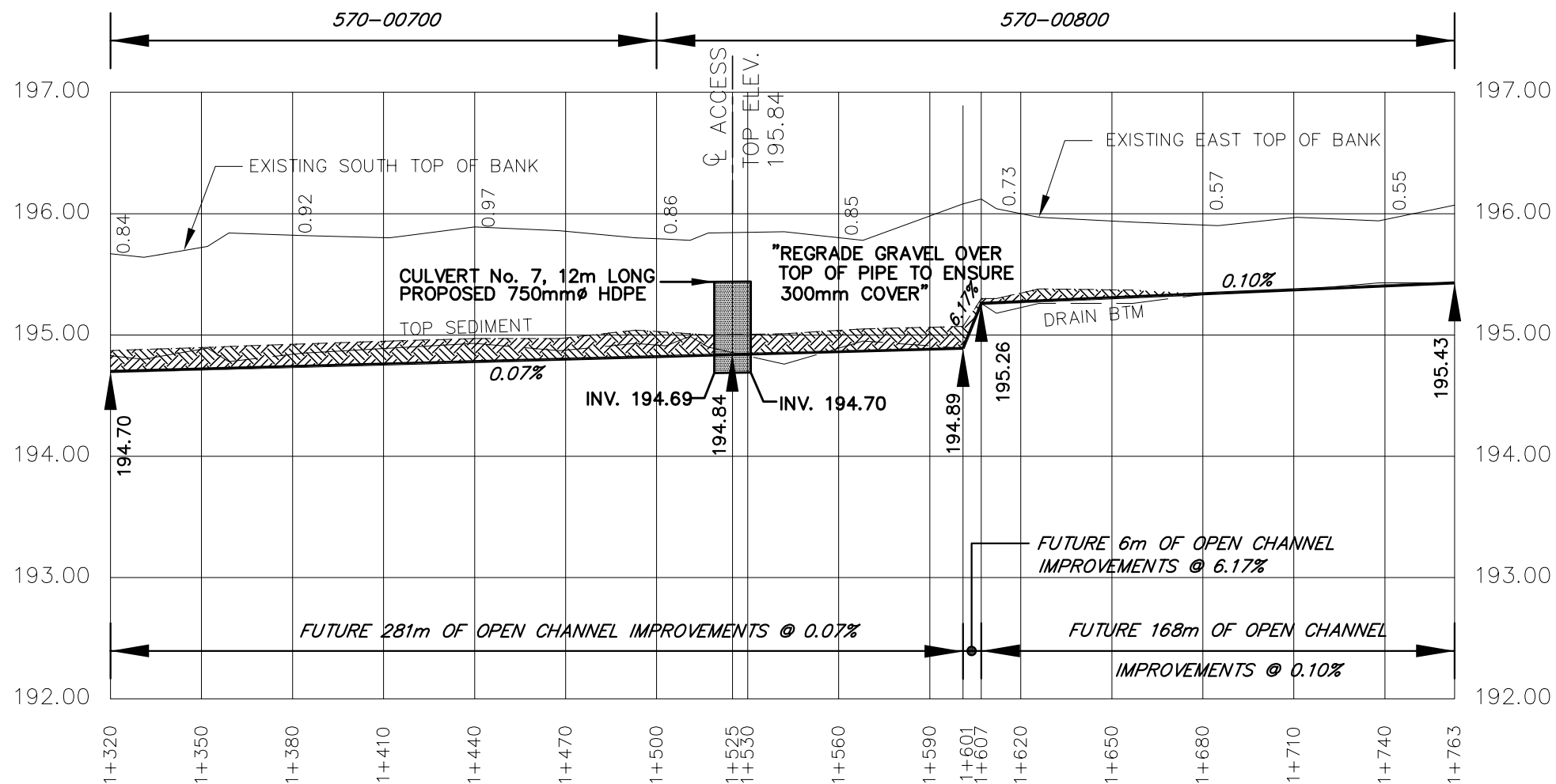
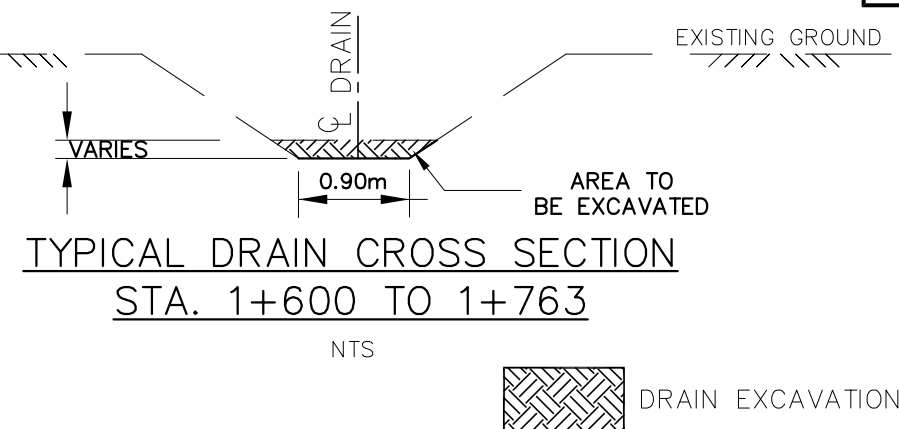
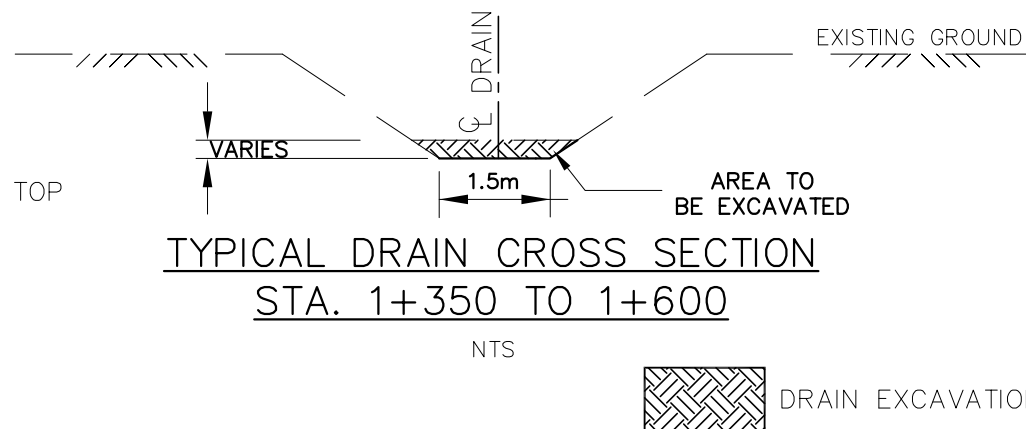

4218 Oil Heritage Road  
Petrolia Ontario, N0N 1R0  
Phone: (519) 882-0032 Fax: (519) 882-2233

PROJECT No.  
2025-1758

APPROVED	NO.	REVISIONS	DATE	BY
J. WARNER				
CHECKED D. MOORES	1	FINAL REPORT	MAR. 12, 2026	CS
DRAWN C. SAUNDERS				

SCALE: 1:2,000  
0 20 40 60m

**TOWN of KINGSVILLE**  
**ASH - CAMERON DRAIN**  
**PROFILE**

**4**  
**OF 7**

DRAWING NAME:  
Ash-Cameron Drain Profile 3

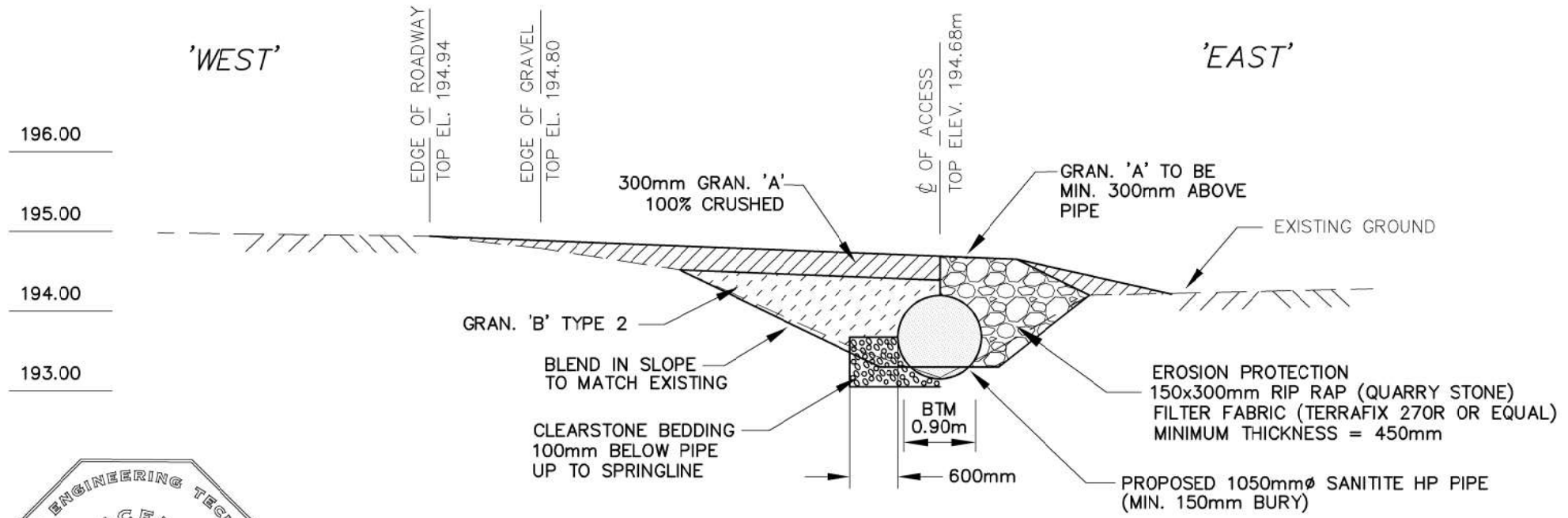

**BM No. 1 ELEV. 195.21m**  
 TOP WEST END OF EXISTING  
 1500Ø CSP ON NORTH SIDE OF  
 SOUTH TALBOT RD. AT  
 CULVERT No. 1 AT STA. 0+013

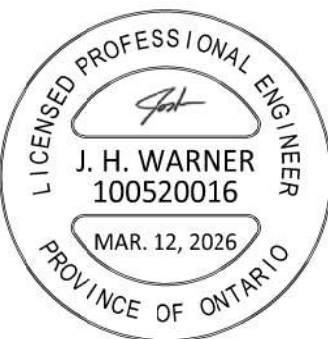

**PROPOSED PIPE END SECTION**

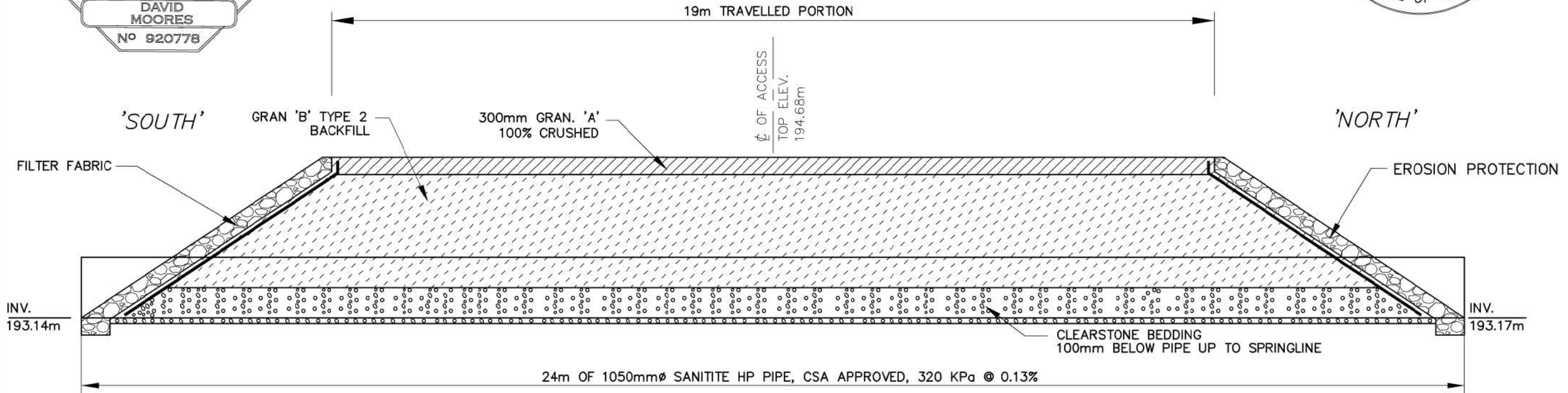

**PROPOSED CROSS-SECTION**

NOTE: LOCATION REFERENCED  
 USING DRAWING NORTH



4218 Oil Heritage Road  
 Petrolia Ontario, N0N 1R0  
 Phone: (519) 882-0032 Fax: (519) 882-2233

APPROVED	NO.	REVISIONS	DATE	BY
J. WARNER				
CHECKED	1	FINAL REPORT	MAR. 12, 2026	DM
D. MOORES				
DRAWN				
C. SAUNDERS				

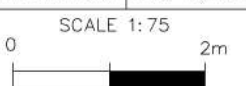

**TOWN of KINGSVILLE**  
 ASH - CAMERON DRAIN  
 CULVERT No. 2 DETAILS

**5  
 OF 7**

Last Updated: March 12, 2026

DRAWING NAME:  
 Ash-Cameron Drain Culvert No. 2 Details

PROJECT No.  
 2025-1758

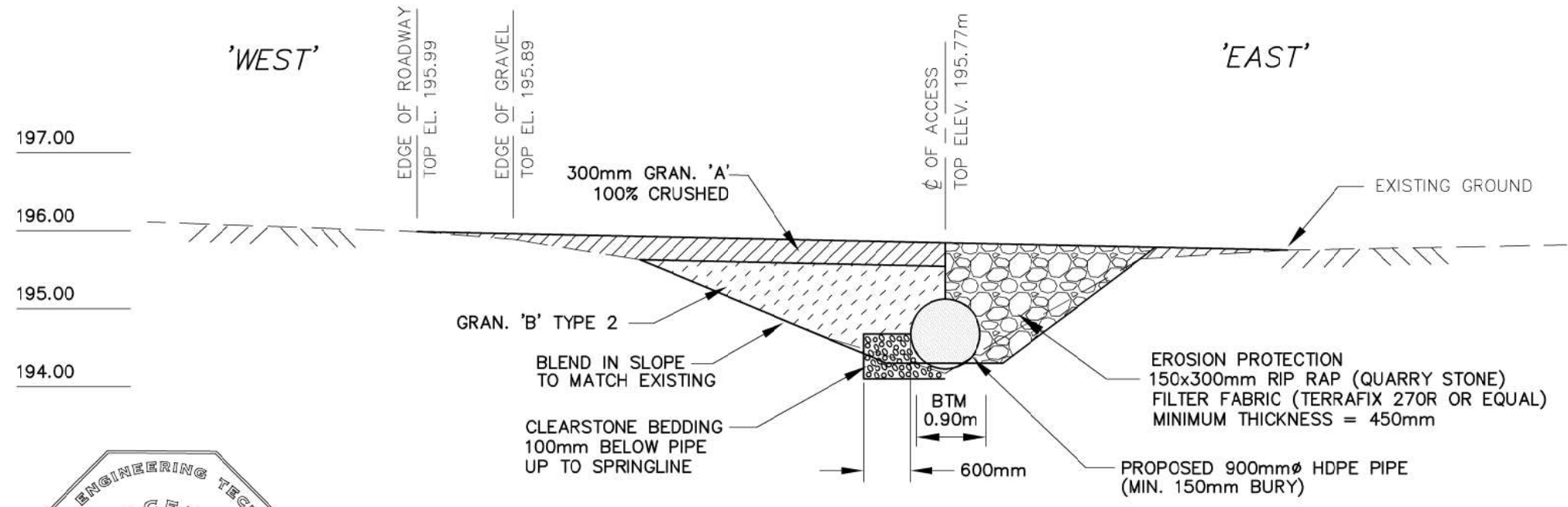

BM No. 4 ELEV. 195.90m  
 TOP OF EXISTING CB AT  
 CULVERT No. 6 AT STA. 1+142

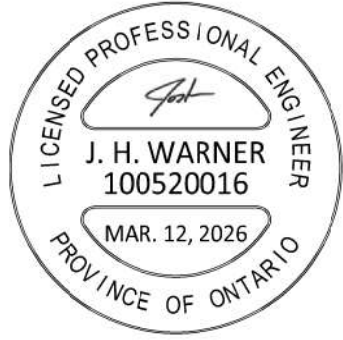

**PROPOSED PIPE END SECTION**

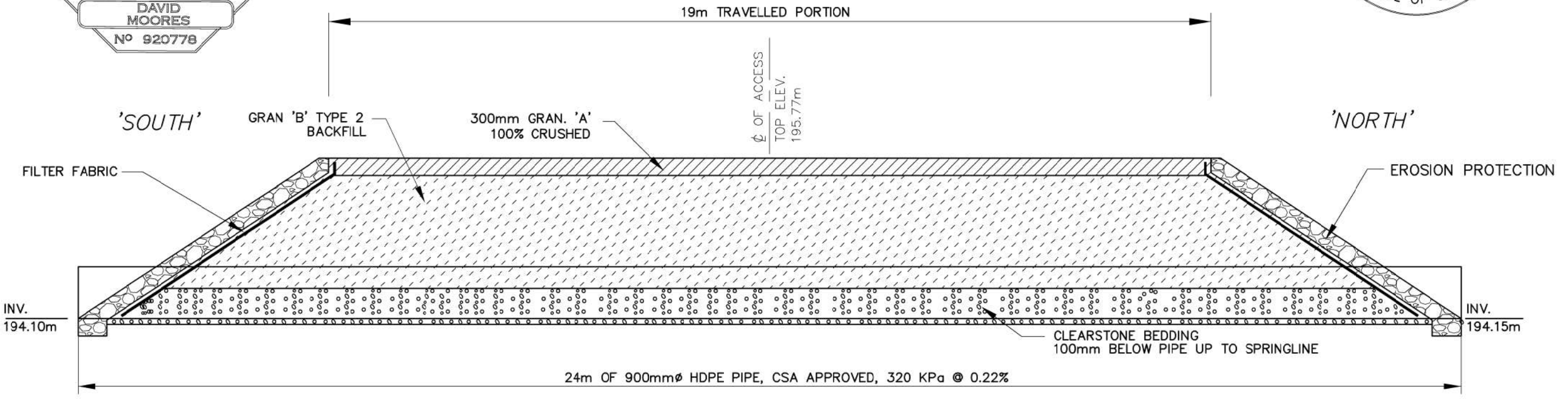

**PROPOSED CROSS-SECTION**

NOTE: LOCATION REFERENCED USING DRAWING NORTH

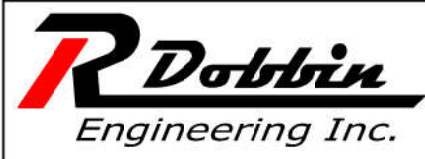

4218 Oil Heritage Road  
 Petrolia Ontario, N0N 1R0  
 Phone: (519) 882-0032 Fax: (519) 882-2233

APPROVED	J. WARNER	NO.	REVISIONS	DATE	BY
CHECKED	D. MOORES	1	FINAL REPORT	MAR. 12, 2026	CS
DRAWN	C. SAUNDERS	SCALE 1:75			

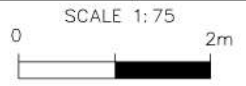

**TOWN of KINGSVILLE**  
 ASH CAMERON DRAIN  
 CULVERT No. 5 DETAILS

**6 OF 7**

Last Updated: March 12, 2026

DRAWING NAME: Ash-Cameron Drain Culvert No. 5 Details  
 PROJECT No: 2025-1758

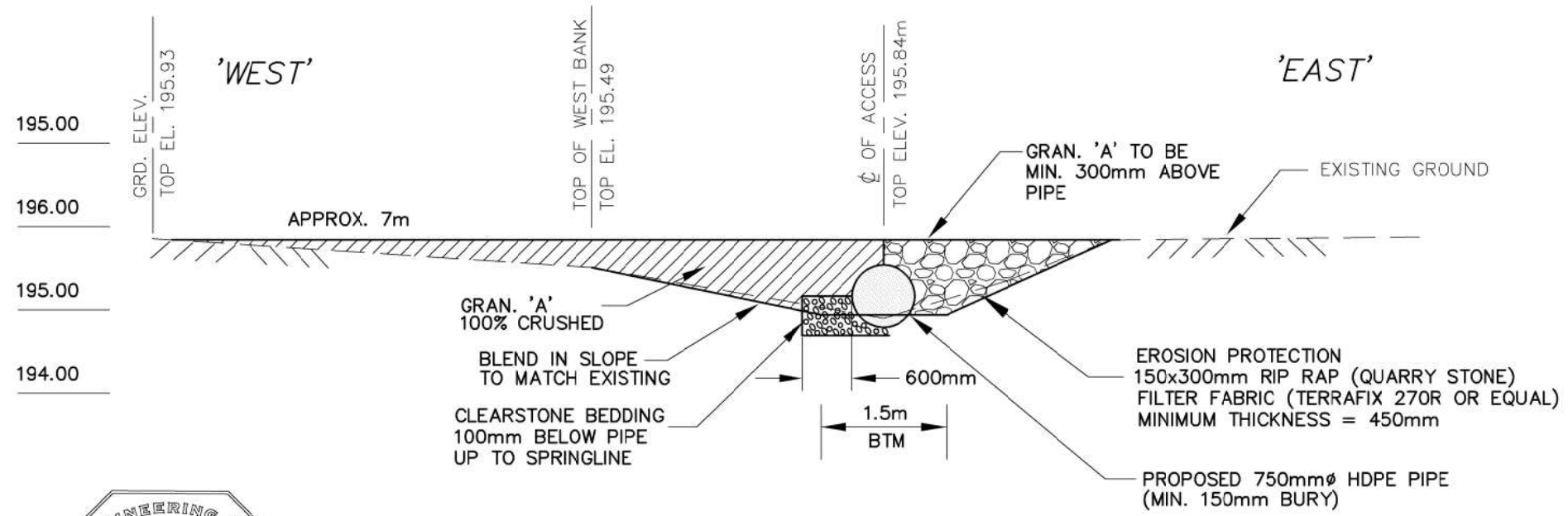

**BM No. 4 ELEV. 195.90m**  
 TOP OF EXISTING CB AT  
 CULVERT No. 6 AT STA. 1+142

NOTE:  
 R. DOBBIN TO PROVIDE BM  
 NEAR PROP. CULVERT No. 7  
 AT TIME OF CONSTRUCTION.



**PROPOSED PIPE END SECTION**

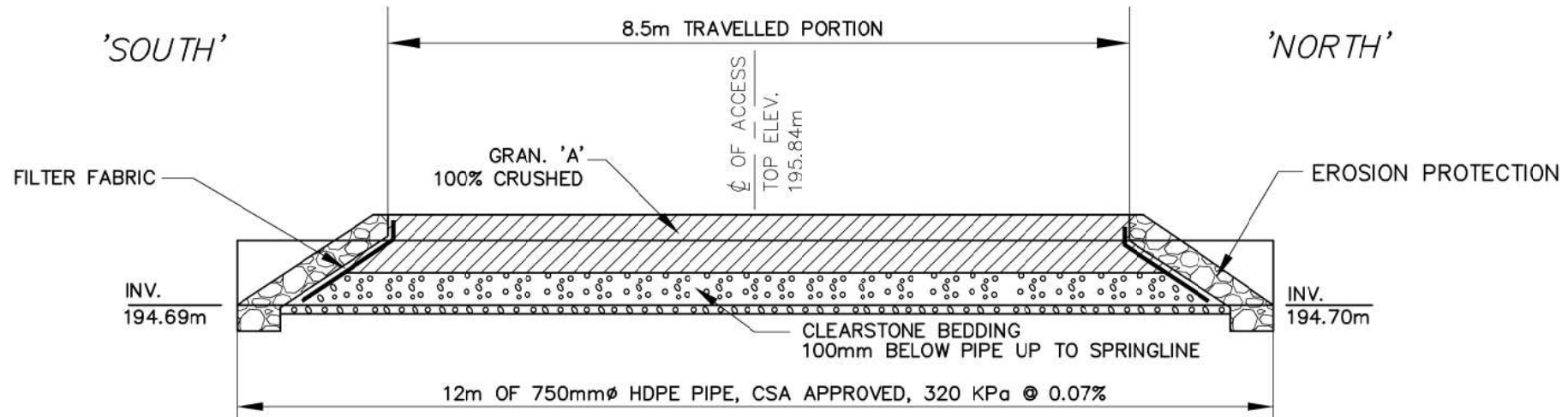

**PROPOSED CROSS-SECTION**

NOTE: LOCATION REFERENCED  
 USING DRAWING NORTH



4218 Oil Heritage Road  
 Petrolia Ontario, N0N 1R0  
 Phone: (519) 882-0032 Fax: (519) 882-2233

APPROVED	NO.	REVISIONS	DATE	BY
J. WARNER				
CHECKED	1	FINAL REPORT	MAR. 12, 2026	CS
D. MOORES				
DRAWN				
C. SAUNDERS				

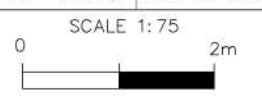

**TOWN of KINGSVILLE**  
 ASH CAMERON DRAIN  
 CULVERT No. 7 DETAILS

**7  
 OF 7**

DRAWING NAME:  
 Ash-Cameron Drain Culvert No. 7 Details

PROJECT No.  
 2025-1758

Last Updated: March 12, 2026

## The Corporation of the Town of Kingsville

**To:** Mayor and Members of Council

**Prepared By:** Lu-Ann Marentette, Drainage Superintendent

**Department:** Planning and Development - Capital Projects and Engineering

**Date of Meeting:** April 20, 2026

**Subject:** Ferry Drain – Improvements to Culvert Crossings

---

### Recommended Action

That Engineer's Report prepared by R. Dobbin Engineering pursuant to Section 78 of the Drainage Act, and dated March 12, 2026, on for improvements to culvert crossings on Ferry Drain, specifically for a shared crossing for Roll # 450-02501 and Roll # 450-02510; and to legalize a second crossing for Roll# 450-00108, **be adopted**.

And that By-law 28-2026, being a By-law to provide for improvements to the Ferry Drain, in the Town of Kingsville, in the County of Essex, **be provisionally adopted** during the by-law stage of the agenda.

### Background

In the summer of 2025, the landowner at Roll # 450-02501 submitted an application to replace his existing entrance. This entrance was also used by the residential lot to the west.

During the site meeting it was also discovered that the culvert crossing for Roll # 450-00108 was not legal nor was it in good shape.

### Discussion

R. Dobbin Engineering has reviewed the properties and has created their report. He recommends the following:

1. The first crossing will now be constructed over the property lines of Roll #450-02501 and Roll # 450-02510 to serve both parcels.
2. The second crossing, at Roll #450-00108, should be a 1200 mm diameter culvert, however, it currently has a 900mm pipe on the east end. This pipe will have to be removed and corrected in order for it to become a legal part of the drain.

### Financial Considerations

Total cost including engineering and construction	\$58,500
Landowners	\$57,444
Kingsville Roads 6E and 7E	\$ 1,056

**Environmental Considerations**

A permit from the ERCA will be required.

**Consultations**

R Dobbin Engineering  
ERCA

**Prepared By:**



Lu-Ann Marentette  
Drainage Superintendent

**Report Approval Details**

Document Title:	Ferry Drain - Improvements to Culvert Crossings.docx
Attachments:	Ferry Drain Report (March 12 2026).pdf
Final Approval Date:	April 15, 2026

This document and all of its attachments were approved and signed as outlined below:

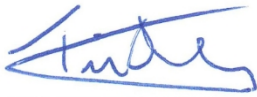

Tim Del Greco, Senior Manager of Capital Projects and Engineering



Richard Wyma, Director of Planning and Development



John Norton, Chief Administrative Officer



4218 Oil Heritage Road  
Petrolia, Ontario, N0N 1R0  
Phone: (519) 882-0032 Fax: (519) 882-2233  
www.dobbineng.com

March 12, 2026

The Mayor and Council  
The Corporation of the  
Town of Kingsville  
2021 Division Road North  
Kingsville, Ontario  
N9Y 2Y9

**Re: Ferry Drain**

In accordance with your instructions, we have undertaken an examination of the Ferry Drain with regards to making drainage improvements in Lot 22, Concession 6 ED in the Town of Kingsville. The work includes the replacement of a shared crossing between Roll No. 450-02501 and Roll No. 450-02510, as well as reviewing the size and installation of the access crossing at Roll No. 450-00108.

Authorization under the *Drainage Act*

This Engineer's Report has been prepared under Section 78 of the *Drainage Act* as per the request of an affected Owner.

R. Dobbin Engineering Inc. was appointed on July 8, 2025.

Section 78 of the *Drainage Act* states that, where, for the better use, maintenance or repair of any drainage works constructed under a bylaw passed under this *Act*, or of lands or roads, it is considered expedient to change the course of the drainage works, or to make a new outlet for the whole or any part of the drainage works, or to construct a tile drain under the bed of the whole or any part of the drainage works as ancillary thereto, or to construct, reconstruct or extend embankments, walls, dykes, dams, reservoirs, bridges, pumping stations, or other protective works as ancillary to the drainage works, or to otherwise improve, extend to an outlet or alter the drainage works or to cover the whole or any part of it, or to consolidate two or more drainage works, the Council whose duty it is to maintain and repair the drainage works or any part thereof may, without a petition required under Section 4 but on the report of an Engineer appointed by it, undertake and complete the drainage works as set forth in such report.

### Existing Drainage

The Ferry Drain is an open channel drain located in Lots 22 & 23, Concession 6 ED, 7 ED, and 8 ED. The drain outlets into the Ruscom River just North of Road 8E.

The drain was last improved under an Engineer's Report dated April 15, 1971 prepared by William J. Settington, P.Eng. Under this report, the entire Ferry Drain was brushed and cleaned out.

An Engineer's Report dated January 9, 1959 was prepared by Wm. D. Colby, Consulting Civil Engineer. Under this report, a new access bridge in Lot 22, Concession 6 ED was constructed. This bridge is the access that has been requested for replacement under this report.

### On-site Meeting

An On-site Meeting was held on September 17, 2025.

The following were present at the meeting:

- David Moores (R. Dobbin Engineering)
- Lu-Ann Marentette (Town of Kingsville)
- Clare Janisse (Town of Kingsville)
- Mark Fishleigh (County of Essex)
- Scott Douglas (Landowner)
- Dave Boulton (Landowner)
- Michelle Boulton (Landowner)
- Christina Lapointe (Landowner)
- Chris Lapointe (Landowner)

The following is a brief summary of the meeting:

- General discussion of the *Drainage Act* and Landowners rights under the *Drainage Act*.
- Landowners were made aware that a request to replace a shared crossing was received by the Town and that this was the first step in the public process.
- The current crossing is failing and is very narrow for the farmer to use. It is a shared access between Roll No. 450-02501 and Roll No. 450-02510.
- As this crossing was originally constructed under an Engineer's Report prepared under the *Drainage Act*, a cost share could be applied to the new crossing. It was explained that a portion would be assessed to the benefiting owners and a portion would be assessed to upstream land and roads.
- The Drainage Superintendent requested that the new crossing located at Roll No. 450-00108 be reviewed for proper sizing and to be incorporated into the Ferry Drain as there was no approval given to install that access crossing.

- No other concerns were received.

Discussion and Investigation

The drain was surveyed along Road 7E and a crossing inspection report was completed for the shared access at Roll No. 450-02501 and Roll No. 450-02510 and for the crossing at Roll No. 450-00108.

The open channel consists of heavy brush. Our survey did not encompass the entire drain, as our appointment was to only investigate the crossings and those in attendance at the On-site Meeting did not wish to have any additional work completed. Therefore, the amount of sediment in the channel bottom was not investigated.

Below is a summary of the condition of the existing crossings:

<b>Crossing No.</b>	<b>Location</b>	<b>Existing Crossing Size &amp; Details</b>	<b>Condition</b>
1	Sta. 0+152 Roll No. 450-02501 & Roll No. 450-02510	5m wide open span bridge crossing with concrete abutments, steel I-beams, concrete deck, and gravel drive	Poor condition, very narrow for farm equipment, the deck is failing and requires replacement
2	Sta. 0+233 Roll No. 450-00108	12m x 1200mm dia. HDPE & 4m x 900mm dia. HDPE with one sloping endwall and one vertical endwall and a gravel drive over top of the crossing that meets a concrete drive to the house	Good condition, although the 900mm section is undersized

Crossing No. 1 located at Sta. 0+152 is a shared access to properties with Roll No. 450-02501 and Roll No. 450-02510. There is a legal easement agreement registered on title between the two properties for use of the crossing. The crossing is currently fully located on the property with Roll No. 450-02501. Due to the location of the house, the current driveway, and the existing hydro pole, the new proposed crossing will not be able to split on the property line as originally discussed at the on-site meeting.

Crossing No. 2 located at Sta. 0+233 was installed privately by the Owner as the result of a severance. The Town of Kingsville has no record that this crossing was installed under the Report of an Engineer under the *Drainage Act*. The Town Drainage Superintendent requested that the crossing be reviewed for sizing and capacity and to incorporate it into

the Ferry Drain. Our investigation revealed that the crossing is a total length of 16m. It consists of 12m of 1200mm dia. HDPE pipe and 4m of 900mm dia. HDPE pipe. The upstream endwall is a sloping endwall constructed with rip rap quarry stone. The downstream endwall is a vertical endwall constructed of quikrete concrete bags. Calculations of the required size pipe at this location revealed that the 900mm section is too small for the capacity required and either needs to be removed or replaced with a 1200mm HDPE pipe.

#### Public Information Centre Meeting

R. Dobbin Engineering submitted a Draft Engineer's Report dated January 30, 2026. A Public Information Centre Meeting was held on March 11, 2026 to discuss the contents of the Report.

The following were present at the meeting:

- David Moores (R. Dobbin Engineering)
- Lu-Ann Marentette (Town of Kingsville)
- Clare Janisse (Town of Kingsville)
- Ronald Thompson (Landowner)
- Ashor Khoshaba & Partner (Landowner)
- Chris Eccles (Landowner)

The following is a brief summary of the meeting:

- The Drainage Superintendent provided introductions and gave a brief explanation of the project.
- An overview of the *Drainage Act* was provided and it was explained to the landowners in attendance how the project will affect them and more details of the project was provided.
- The Owner of Roll No. 450-00108 expressed that they have just purchased the property and were not aware of this project. The Drainage Superintendent confirmed that they were invited to the On-site Meeting.
- The cost breakdown was reviewed with the landowners present and it was explained to them how the estimate of cost was reached. Residents were advised that the Town does not debenture costs, but there are payment plans available depending on the invoice amount. When the invoice is received, there will be details on to pay up front or be put on a payment plan.
- The Owner of Roll No. 450-02501 was advised that his property will qualify for a 1/3 farm tax class grant which the Town will apply for on his behalf and the grant amount will be deducted from his invoice.

- Residents were advised that there will be a meeting for Council to consider the report, but they do not need to be present unless they would like to address Council. This meeting will only be to discuss the scope of the work. They will also be invited to the Court of Revision to address assessment concerns.
- The Owner of Roll No. 450-02501 inquired about the tendering process and was advised it will be put up for competitive bid.
- It was explained that both the Engineer and Drainage Superintendent will complete inspection of the project during construction.
- The Owner of Roll No. 450-00108 asked how long their culvert has been an issue and the Drainage Superintendent advised that it was discovered when responding to the drainage request from the Owner of Roll No. 450-02501, but stated that it had been installed illegally.
- When construction begins, the Contractor will notify landowners when the bridge will be removed so they can make parking arrangements.
- The Drainage Superintendent reiterated that if the residents have no further concerns, they do not need to attend the Consideration Meeting or the Court of Revision.
- No additional requests for work were received at the meeting.

#### Recommendations

It is therefore recommended that the following work be carried out:

1. Crossing No. 1 at Station 0+152 shall be replaced.
2. Crossing No. 2 at Station 0+233 shall be incorporated and the downstream end shall be replaced.

#### Design

All agricultural and residential crossings have been designed to meet a 1 in 5-year storm event.

#### Estimate of Cost

It is recommended that the work be carried out in accordance with the accompanying Specification of Work and the Profile, which forms part of this Report. There has been prepared an Estimate of Cost in the amount of \$58,500.00 including the cost of engineering. A Plan has been prepared showing the location of the work and the approximate drainage area. An estimate for tendering, inspection, and contract administration has been provided. This estimate includes attendance at the Meeting to

Consider and the Court of Revision, but does not include any appearances before appeal bodies beyond the Court of Revision.

### Assessment

As per Section 21 of the *Drainage Act*, the Engineer in his report shall assess for benefit and outlet for each parcel of land and road liable for assessment.

Lands, roads, buildings, utilities, or other structures that are increased in value or are more easily maintained as a result of the construction, improvement, maintenance, or repair of a drainage works may be assessed for benefit. (Section 22)

Lands and roads that use a drainage works as an outlet, or for which, when the drainage works is constructed or improved, an improved outlet is provided either directly or indirectly through the medium of any other drainage works or of a swale, ravine, creek, or watercourse may be assessed for outlet. The assessment for outlet shall be based on the volume and rate of flow of the water artificially caused to flow into the drainage works from the lands and roads liable for such assessments. (Section 23)

The Engineer may assess for special benefit any lands for which special benefits have been provided by the drainage works. (Section 24)

A Schedule of Assessment for the lands and roads affected by the work and therefore liable for the cost thereof is attached as per the *Drainage Act*. Also, assessments may be made against any public utility or road authority, as per Section 26 of the *Drainage Act*, for any increased cost for the removal or relocation of any of its facilities and plant that may be necessitated by the construction or maintenance of the drainage works. Items to be assessed under Section 26, as specified, shall be tendered separately with the actual cost plus a portion of the engineering (25% of the construction cost).

The estimated cost of the drainage works has been assessed in the following manner:

1. Crossing No. 1 is a shared access between Roll No. 450-02501 & Roll No. 450-02510. The cost of this replacement has been assessed with 50% of the cost applied as a benefit assessment. This 50% has been split equally between the two benefiting properties. The remaining 50% has been applied as an outlet assessment against upstream land and roads based on equivalent hectares.
2. The cost to incorporate Crossing No. 2 into the Ferry Drain and to replace the downstream portion of the crossing has been assessed with 100% of the cost applied as a benefit assessment to the property.

All final costs included in the cost estimate of this report shall be pro-rated based on the Schedule of Assessment. Any additional costs shall be assessed in a manner as determined by the Engineer.

#### Allowances

Under Section 29 of the *Drainage Act*, the Engineer in his report shall estimate and allow in money to the Owner of any land that it is necessary to use for the construction or improvement of a drainage works or for the disposal of material removed from a drainage works. This shall be considered an allowance for right of way.

Under Section 30 of the *Drainage Act*, the Engineer shall determine the amount to be paid to persons entitled thereto to damage, if any, to ornamental trees, fences, land, and crops occasioned by the disposal of material removed from a drainage works. This shall be considered an allowance for damages.

In this Report, no allowances have been applied as work is proposed to take place from the road side of the drain.

#### Approvals and Drain Classification

The Ferry Drain is currently classified as a class “F” drain along its length.

Class “F” drains are intermittent or ephemeral (dry for more than three consecutive months). The proposed work will require a permit from the Essex Region Conservation Authority. No authorization is required from Fisheries and Oceans if the work is completed in the dry and the Culvert BMP is followed. No works can take place until all approvals are received.

The proposed improvements and crossing replacements will have very little effect on the drainage works if carried out during low flows in the channel.

#### Restrictions

No trees or shrubs shall be planted nor shall permanent structures be erected within 10m of either side of the proposed drain without prior written permission of Council. If trees are planted that interfere with access for future maintenance of the drainage works, they shall be removed at the expense of the Owner.

Attention is also drawn to Sections 80 and 82 of the *Drainage Act* that refer to the obstruction of a drainage works.

### Agricultural Grant

It is recommended that application for subsidy be made for eligible farm tax class agricultural properties by the Township. The Ontario Ministry of Agricultural, Food, and Agribusiness offers the “Agricultural Drainage Infrastructure Program (ADIP)”. This program will pay 1/3 of any eligible agricultural assessments that meet the criteria contained within the policy.

Any assessments against non-agricultural properties are shown separately in the Schedule of Assessment.

### Maintenance

The open channel shall be maintained and repaired in accordance with the specifications and drawings contained within the last applicable drainage reports.

The crossings addressed under this Report shall be maintained and repaired in accordance with the specifications and drawings contained within this report and assessed out as follows:

1. Crossing No. 1 at Station 0+152 shall be assessed with 50% of the cost applied as a benefit assessment. This 50% shall be split equally between Roll No. 450-02510 & Roll No. 450-02501. The remaining 50% of the cost shall be assessed as an outlet assessment against upstream land and roads based on equivalent hectares shown on the attached Schedule of Assessment.
2. Crossing No. 2 at Station 0+233 shall be assessed with 75% of the cost applied as a benefit assessment to Roll No. 450-00108 and the remaining 25% shall be assessed as an outlet assessment against upstream land and roads based on equivalent hectares.

Each property is allowed one crossing over each municipal drain with any additional crossings on the property maintained and repaired 100% by the owner.

Any extra cost as a result of the location of underground utilities shall be assessed 100% to the utility as per Section 26 of the *Drainage Act*.

These above conditions will apply unless otherwise altered under the provisions of the *Drainage Act*.

All of the above is submitted for your consideration.

Yours truly,

Report Prepared By:



David Moores, C.E.T

Report Approved By:



Josh Warner, P. Eng.

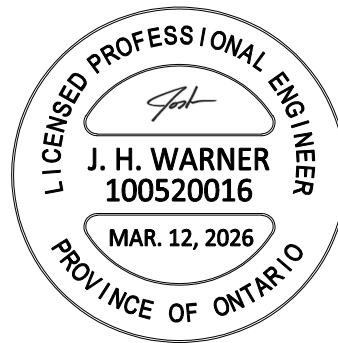



Ferry Drain  
The Corporation of the  
Town of Kingsville  
March 12, 2026

## **SPECIFICATION OF WORK**

### **1. Scope of Work**

The work includes the replacement of a shared open span concrete bridge crossing with a 18m x 1200mm diameter Sanitite HP pipe for Roll No. 450-02501 and Roll No. 450-02510. The work also includes the removal of 4m x 900mm diameter HDPE pipe from the downstream section of the crossing at Roll No. 450-00108 and replacing it with a new 6m x 1200mm diameter HDPE pipe. All works are located in Lot 22, Concession 6 ED on Road 7E in the Town of Kingsville.

### **2. General**

Each tenderer must inspect the site prior to submitting their tender and satisfy themselves by personal examination as to the local conditions that may be encountered during this project. The tenderer shall make allowance in the tender for any difficulties which they may encounter. Quantities or any information supplied by the Engineer is not guaranteed and is for reference only.

All work and materials shall be to the satisfaction of the Drainage Superintendent who may vary these specifications as to minor details but in no way decrease the proposed capacity of the drain.

The Contractor shall be responsible for the notification of all utilities prior to the start of construction.

### **3. Plans and Specifications**

These specifications shall apply and be part of the contract. This specification of work shall take precedence over all plans and general conditions pertaining to the contract. The Contractor shall provide all labour, equipment, and supervision necessary to complete the work as shown in the plans and described in these specifications. Any work not described in these specifications shall be completed according to the Ontario Provincial Standard Specifications and Standard Drawings.

#### **4. Health and Safety**

The Contractor at all times shall be responsible for health and safety on the worksite including ensuring that all employees wear suitable personal protective equipment including safety boots and hard hats.

The Contractor shall be responsible for traffic control as per the Ontario Traffic Manual Book 7 – Temporary Conditions (latest revision) when working on public road allowances. A copy of the traffic control plan shall be kept onsite at all times. The Contractor shall maintain suitable barricades, warning lights, and temporary traffic notices, at his expense, in their proper position to protect the public both day and night. Flagmen are the responsibility of the Contractor when working on the road allowance and when entering or exiting a worksite onto a roadway.

The Contractor shall be responsible to ensure that all procedures are followed under the Occupational Health and Safety Act to ensure that work sites are safe and that accidents are prevented. In the event of a serious or recurring problem, a notice of noncompliance will be issued. The Contractor will be responsible for reacting immediately to any deficiency and correcting any potential health and safety risk. Continuous disregard for any requirement of the Occupational Health and Safety Act could be cause for the issuance of a stop work order or even termination of the contract.

The Contractor shall also ensure that only competent workers are employed onsite and that appropriate training and certification is supplied to all employees.

#### **5. Workplace Safety and Insurance Board**

The Contractor hereby certifies that all employees and officers working on the project are covered by benefits provided by the Contractor. The WSIB clearance certificate must be furnished prior to the execution of the Contract.

#### **6. Weather Conditions**

Work shall be carried out under this Report and completed within the agreed upon Schedule as permitted by weather. The Engineer or the Drainage Superintendent reserves the right to restrict construction and access to the site based on the weather and ground conditions.

## **7. Access and Working Area**

Access to the drain for the replacement of the crossings shall be from Road 7E.

The working area at each crossing shall be from the road side of the drain. The working area shall extend 10m upstream and downstream of the crossing. The property side of the crossing can be used if needed during the construction, at the discretion of the Drainage Superintendent.

## **8. Crossing No. 1 – Sta 0+152**

This item shall apply to the access crossing located at Sta. 0+152. This crossing is a shared access between Roll No. 450-02510 and Roll No. 450-02501.

The existing crossing is a 5m wide open span bridge that consists of steel I-beams and a concrete deck that sit on concrete abutments. There is a gravel drive on top of the concrete deck.

The existing gravel can be stockpiled for use in backfill of the new crossing. The concrete deck and steel I-beams shall be removed and disposed of offsite to a location determined by the Contractor. The concrete abutments may be left in place.

The crossing shall be replaced with 18m of 1200 mm diameter Sanitite HP pipe with rip rap endwalls, full granular backfill, and a gravel drive.

The pipe shall be Sanitite HP pipe, minimum 320 kPa pipe stiffness, and CSA certified with bell and spigot joints.

The proposed crossing shall be installed in the same general location as the existing crossing. The crossing shall be installed with the invert 10% (minimum 150mm) below the proposed channel bottom elevation and to the grade shown on the Profile. The exact location will be determined in the field at the time of construction. The intention is to start at the utility pole and head east.

The crossing may be moved upstream or downstream as necessary to avoid existing tile outlets. If they cannot be avoided the pipes shall be extended downstream of the proposed crossing and shall be done with non-perforated HDPE agricultural tubing with a manufactured coupling, elbow and rodent grate. Any tile outlets extended as a result of extra length requested by an owner shall be extended at the owner's expense.

The bottom of the excavation shall be excavated to the required depth with any over excavation backfilled with clearstone. When the pipe has been installed to the proper grade and depth, the excavation shall be backfilled with clearstone from 100mm below the bottom of the pipe up to the springline of the pipe. Care shall be taken to ensure that the backfill on either side of the crossing does not differ by more than 300 mm so that the pipe is not displaced. The crossing shall be backfilled from the springline to 300mm of finished grade with granular "B" type 2 or 100% crushed granular "A". The top 300mm for shall be backfilled with compacted 100% crushed granular "A" material to finished grade.

All backfill shall be free from deleterious material. All granular material shall be mechanically compacted to 98% modified standard proctor density. All backfill material above the springline shall be mechanically compacted using appropriate compaction equipment.

The crossing shall be installed as per manufacturer recommendations with a minimum cover of 300mm over top of the pipe measured from the top of the crossing to finished grade. It shall be the responsibility of the Contractor to ensure the crossing has no traffic on it until the minimum cover is met.

End protection shall be rip rap quarry stone placed with a minimum slope of 1.5:1. The rip rap shall consist of 150 mm x 300 mm quarry stone or approved equal. The area to receive the rip rap shall be graded to a depth of 450mm below finished grade. Filter fabric (Terrafix 250R or approved equal) shall then be placed with any joints overlapped a minimum 600mm. The quarry stone shall then be placed with the smaller pieces placed in the gaps and voids to give it a uniform appearance.

### **9. Crossing No. 2 – Sta 0+233**

This item shall apply to the crossing located at Sta. 0+233. This crossing provides access to Roll No. 450-00108.

The crossing is a total length of 16m. It consists of 12m of 1200mm dia. HDPE pipe and 4m of 900mm dia. HDPE. The upstream endwall is a sloping endwall constructed with rip rap quarry stone. The downstream endwall is a vertical endwall constructed of quikrete concrete bags. There is gravel over the top of the crossing that meets with a concrete drive that goes to the house.

The downstream 4m section of 900mm shall be carefully removed along with the quikrete concrete bags and disposed offsite to a location determine by the Contractor. The existing gravel can be stockpiled for use in backfill of the new crossing.

The 4m section shall be replaced with 6m of 1200mm diameter HDPE smooth wall pipe. The HDPE pipe shall have a variable pipe stiffness with manufactured couplers. This section of pipe shall be connected to the existing 1200mm pipe using a manufactured HDPE coupler. The crossing shall be installed with the invert 10% (minimum 150mm) below the proposed channel bottom elevation and to grade shown on the Profile.

The bottom of the excavation shall be excavated to the required depth with any over excavation backfilled with clearstone. When the pipe has been installed to the proper grade and depth, the excavation shall be backfilled with clearstone from 100mm below the bottom of the pipe up to the springline of the pipe. Care shall be taken to ensure that the backfill on either side of the crossing does not differ by more than 300 mm so that the pipe is not displaced. The crossing shall be backfilled from the springline to 300mm of finished grade with granular "B" type 2 or 100% crushed granular "A". The top 300mm for shall be backfilled with compacted 100% crushed granular "A" material to finished grade.

All backfill shall be free from deleterious material. All granular material shall be mechanically compacted to 98% modified standard proctor density. All backfill material above the springline shall be mechanically compacted using appropriate compaction equipment.

The crossing shall be installed as per manufacturer recommendations with a minimum cover of 300mm over top of the pipe measured from the top of the crossing to finished grade. It shall be the responsibility of the Contractor to ensure the crossing has no traffic on it until the minimum cover is met.

End protection shall be rip rap quarry stone placed with a minimum slope of 1.5:1. The rip rap shall consist of 150 mm x 300 mm quarry stone or approved equal. The area to receive the rip rap shall be graded to a depth of 450mm below finished grade. Filter fabric (Terrafix 250R or approved equal) shall then be placed with any joints overlapped a minimum 600mm. The quarry stone shall then be placed with the smaller pieces placed in the gaps and voids to give it a uniform appearance.

In the future, the crossing shall be replaced with 18m of 1200 mm diameter Sanitite HP pipe with rip rap endwalls, full granular backfill, and a gravel drive. The Sanitite HP pipe shall have a minimum pipe stiffness of 320 kPa and be CSA certified with bell and spigot joints.

## **10. Silt Fence**

The Contractor shall maintain a dry working area during construction by installing a silt fence downstream of the work area. Under this report, there are two working areas. Silt fences shall be installed downstream of both Crossing No.1 and No.2 prior to commencing any work.

The silt fence shall consist of filter fabric or manufactured silt fence supported with posts (OPSD 219.110). The silt fence shall remain in place until construction is complete. Any sediment that has collected upstream of the silt fence shall be removed prior to the removal of the silt fence.

The location of the silt fence can be changed by the Engineer or Drainage Superintendent.

## **11. Environmental Considerations**

The Contractor shall take care to adhere to the following considerations.

- Operate machinery in a manner that minimizes disturbance to the banks of the watercourse.
- Erosion and sediment control measures must be installed prior to construction to prevent sediment from entering the water body.
- All granular and erosion control materials shall be stockpiled a minimum of 1.5 metres from the top of the bank or excavation. Material shall not be placed in surface water runs or open inlets that enter the channel.
- All activities, including maintenance procedures, shall be controlled to prevent the entry of petroleum products, debris, rubble, concrete, or other deleterious substances into the water. Vehicle and equipment refuelling and maintenance shall be conducted away from the channel, any surface water runs, or open inlets. All waste materials shall be stockpiled well back from the top of the bank and all surface water runs and open inlets that enter the drain.
- When possible, all construction within the open channel shall be carried out during periods of low flow or in dry conditions.

- The Culvert BMP provided in the Guidance Document for maintaining and repairing municipal drains shall be used to isolate the working area. This shall be included in the tender document.
- The Contractor shall conduct regular inspections and maintain erosion and sediment control measures and structures during the course of construction.
- The Contractor shall repair erosion and sediment control measures and structures if damage occurs.
- The Contractor shall remove non-biodegradable erosion and sediment control materials once site is stabilized.
- The Contractor shall remove all construction materials from site upon project completion.

## **12. Benchmarks**

The benchmarks are based on geodetic elevations. Elevations are available at the crossing locations shown on the profile drawings. Where these elevations are on existing crossings to be replaced, they shall be moved prior to the removal of the crossing. Prior to construction, it is the responsibility of the Contractor to perform a benchmark loop and report any discrepancies to the Engineer or Drainage Superintendent.



Ferry Drain  
Town of Kingsville  
March 12, 2026

### Estimate of Cost

To replace a shared crossing between Roll No. 450-02501 and Roll No. 450-02510, as well as portion of another crossing at Roll No. 450-00108.

	Quantity	Unit	Unit Cost	Total
Crossing No. 1 - Station 0+152				
R. & D. Bridge Deck, Gravel, and Steel I-beams	1	LS	2,000.00	2,000.00
Supply and Installation of 1200mmø Santite	18	m	1,050.00	18,900.00
Open Channel Excavation U/S and D/S of Proposed Culvert including disposal (6m)	1	LS	500.00	500.00
Supply Clearstone Bedding	20	t	40.00	800.00
Supply Granular "B" Type II Backfill	100	t	40.00	4,000.00
Supply Granular "A" Driveway	40	t	40.00	1,600.00
Rip Rap Endwalls	20	t	100.00	2,000.00
Environmental Considerations (Silt Fence)	1	LS	200.00	200.00
				<u>30,000.00</u>
Crossing No. 2 - Station 0+233				
R. & D. Existing 4.0m Culvert and Conc. Endwalls	1	LS	500.00	500.00
Supply and Installation of 1200mmø HDPE	6	m	950.00	5,700.00
Open Channel Excavation D/S of Proposed Culvert including disposal (3m)	1	LS	250.00	250.00
Supply Clearstone Bedding	10	t	40.00	400.00
Supply Granular "B" Type II Backfill (P)	20	t	40.00	800.00
Supply Granular "A" Driveway (P)	10	t	40.00	400.00
Rip Rap Endwalls	15	t	100.00	1,500.00
Environmental Considerations (Silt Fence)	1	LS	200.00	200.00
				<u>9,750.00</u>
Contingency				<u>2,600.00</u>
Sub Total				42,350.00
Engineering				9,350.00
Estimate for Tendering, Inspection & Contract Admin.				5,000.00
ERCA Fees (Permit)				800.00
				<u>57,500.00</u>
Total Estimate excluding HST				57,500.00
Non-Recoverable HST (1.76%)				1,000.00
				<u>58,500.00</u>
<b>Total Estimate</b>				<b>\$58,500.00</b>



Ferry Drain  
 Town of Kingsville  
 March 12, 2026

**SCHEDULE OF ASSESSMENT**

To replace a shared crossing between Roll No. 450-02501 and Roll No. 450-02510, as well as portion of another crossing at Roll No. 450-00108.

Conc.	Lot or Part	Affected Hect.	Equiv. Ha	Roll No.	Benefit	Outlet	Total
<b>Agricultural Lands (Grantable)</b>							
5 ED	pt. NE 1/4 Lot 22	3.75	3.75	400-06303	-	652.00	652.00
6 ED	pt. SE 1/4 Lot 23	2.83	2.83	450-00600	-	492.00	492.00
	pt. SE 1/4 Lot 23	6.35	6.35	450-00700	-	1,103.00	1,103.00
	Ctr. Pt. Lot 23	8.03	8.03	450-00800	-	1,395.00	1,395.00
	pt. SE 1/4 Lot 22	16.19	16.19	450-00900	-	2,813.00	2,813.00
	pt. SW 1/4 Lot 22	5.26	5.26	450-01000	-	914.00	914.00
	pt. NW 1/4 Lot 22	6.07	6.07	450-01050	-	1,055.00	1,055.00
	pt. NE 1/4 Lot 22 & pt. NW 1/4 Lot 23	18.83	18.83	450-02501	10,804.00	3,271.00	14,075.00
		67.31	67.31	Total Agricultural Lands	10,804.00	11,695.00	22,499.00

Conc.	Lot or Part	Affected Hect.	Equiv. Ha	Roll No.	Benefit	Outlet	Total
<b>Non-Agricultural Lands (Non-Grantable)</b>							
5 ED	pt. NE 1/4 Lot 22	1.46	2.92	400-06300	-	507.00	507.00
	pt. NW 1/4 Lot 23	0.15	0.30	400-06400	-	52.00	52.00
	pt. NW 1/4 Lot 23	0.15	0.30	400-06501	-	52.00	52.00
	pt. NW 1/4 Lot 23	9.01	18.02	400-06500	-	3,131.00	3,131.00
	pt. N 1/2 Lot 23	7.08	14.16	400-06600	-	2,460.00	2,460.00
	pt. N 1/2 Lot 23	2.02	4.04	400-06700	-	702.00	702.00
	pt. N 1/2 Lot 23	1.21	2.42	400-06800	-	420.00	420.00
6 ED	Ctr. Pt. Lot 23	1.53	3.06	400-00820	-	532.00	532.00
	pt. SE 1/4 Lot 22	1.70	3.40	450-00850	-	591.00	591.00
	pt. SE 1/4 Lot 22	0.35	0.70	450-00920	-	122.00	122.00
	pt. NE 1/4 Lot 22	0.43	0.86	450-00108	15,285.00	149.00	15,434.00
	pt. NE 1/4 Lot 22	0.40	0.80	450-02510	10,803.00	139.00	10,942.00
		25.49	50.98	Total Non-Agricultural Lands	26,088.00	8,857.00	34,945.00
<b>Public Lands</b>							
	Road 6E	1.15	4.60	Town of Kingsville	-	799.00	799.00
	Road 7E	0.37	1.48	Town of Kingsville	-	257.00	257.00
		1.52	6.08	Total Public Lands	-	1,056.00	1,056.00
				Total Agricultural Lands	10,804.00	11,695.00	22,499.00
				Total Non-Agricultural Lands	26,088.00	8,857.00	34,945.00
				Total Public Lands	-	1,056.00	1,056.00
		<b>94.32</b>	<b>124.37</b>	<b>Total Assessment</b>	<b>36,892.00</b>	<b>21,608.00</b>	<b>58,500.00</b>

LOT 21

LOT 22

LOT 23

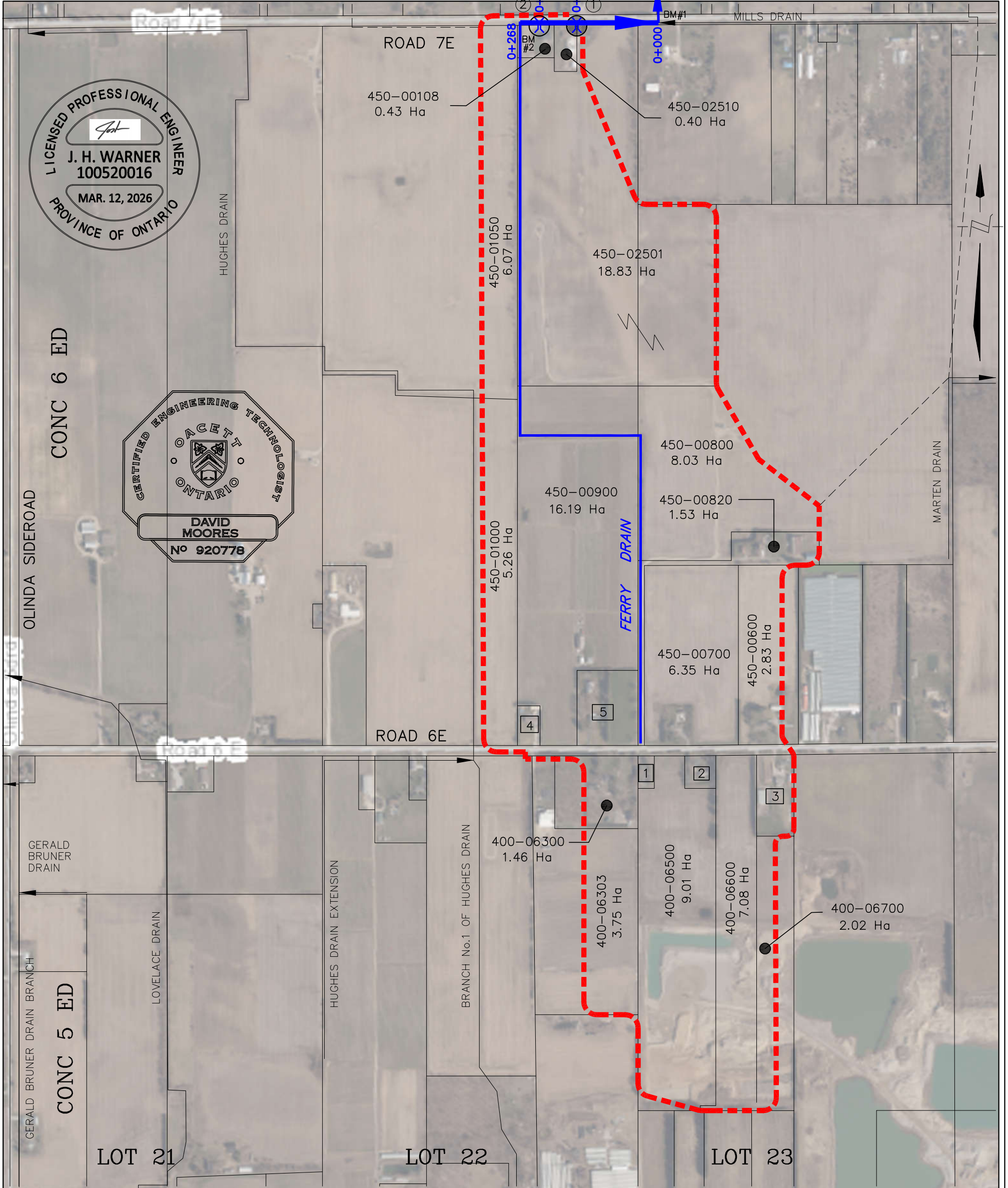

**LEGEND**

- - - DRAINAGE AREA
- FERRY DRAIN
- MUNICIPAL DRAIN
- ① CROSSING NUMBER
- EXISTING CROSSING EAST END TO BE REPLACED
- EXISTING CROSSING TO BE REPLACED

**OWNER INDEX NUMBER**

- 1. 400-06400 0.15 Ha
- 2. 400-06501 0.15 Ha
- 3. 400-06800 1.21 Ha
- 4. 450-00920 0.35 Ha
- 5. 450-00850 1.70 Ha

**R Dobbin**  
Engineering Inc.

4218 Oil Heritage Road  
Petrolia Ontario, N0N 1R0  
Phone: (519) 882-0032 Fax: (519) 882-2233

DRAWING NAME:  
Ferry Drain Plan

PROJECT No.  
2025-1765

APPROVED	NO.	REVISIONS	DATE	BY
J. WARNER				
CHECKED	1	FINAL REPORT	MAR. 12, 2026	DM
D. MOORES				
DRAWN	SCALE: 1:7500			
C. SAUNDERS				

# TOWN of KINGSVILLE

## FERRY DRAIN PLAN

Last Updated: March 12, 2026

**GENERAL NOTES**

- BENCHMARK No.1 ELEV. 198.73  
TOP OF SOUTHEAST CORNER OF EXISTING CONCRETE BOX CULVERT CURB CROSSING ROAD 7E, STATION 0+000.
- BENCHMARK No.2 ELEV. 198.09  
TOP OF EXISTING 1200mmØ HDPE CROSSING No.2, STATION 0+241.
- UPPER NUMBERS ARE DEPTH FROM TOP OF BANK TO DESIGN CHANNEL BOTTOM.
- LOWER NUMBERS ARE THE APPROX. DEPTH FROM TOP OF SEDIMENT TO DESIGN CHANNEL BOTTOM.
- CHANNEL TO BE EXCAVATED U/S & D/S OF CROSSING No. 1 & D/S OF CROSSING No. 2.

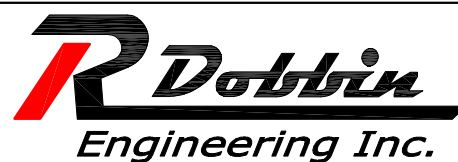
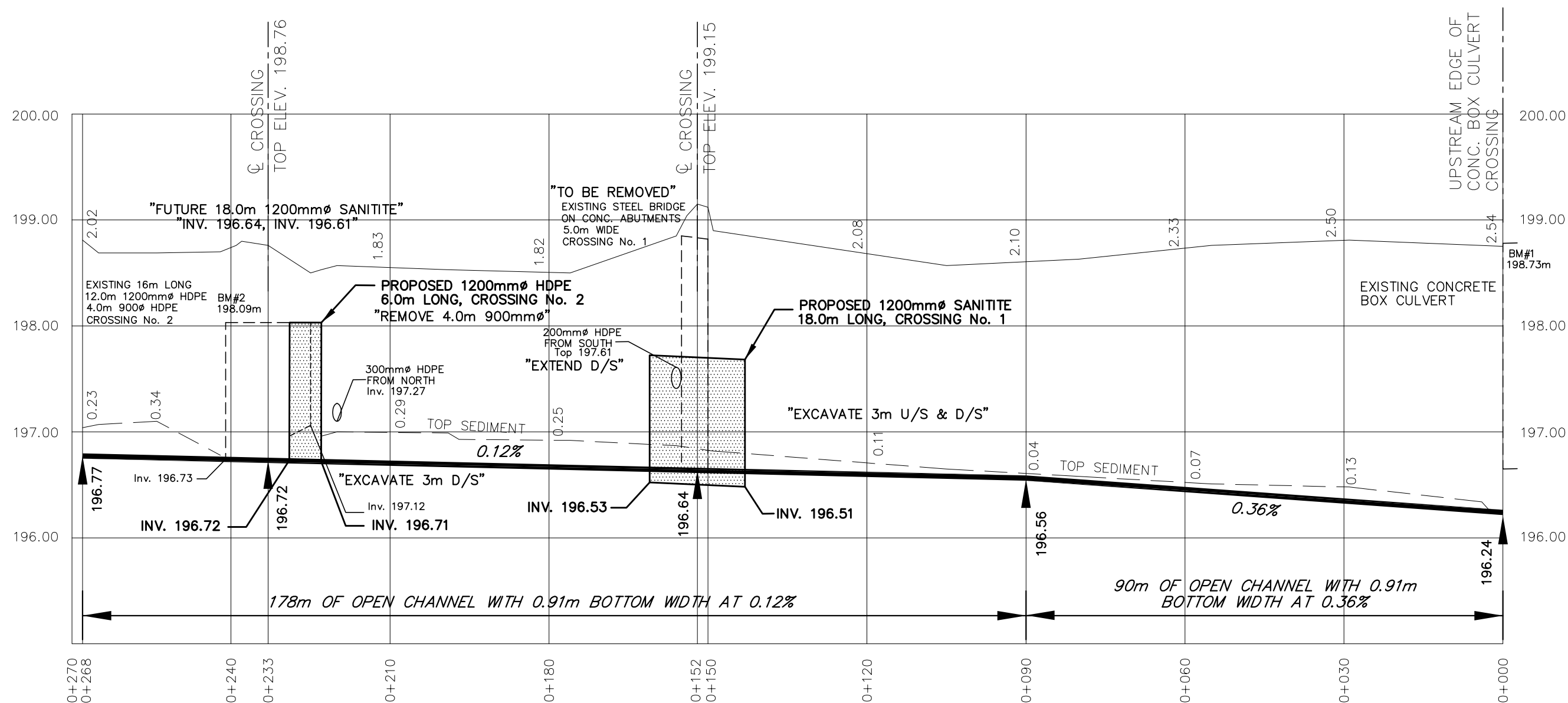

4218 Oil Heritage Road  
Petrolia Ontario, N0N 1R0  
Phone: (519) 882-0032 Fax: (519) 882-2233

DRAWING NAME:  
Ferry Drain Profile

PROJECT No.  
2025-1765

APPROVED	NO.	REVISIONS	DATE	BY
J. WARNER				
CHECKED	1	FINAL REPORT	MAR. 12, 2026	DM
D. MOORES				
DRAWN	SCALE 1: 850			
C. SAUNDERS	0 10 20 30m			

**TOWN of KINGSVILLE**  
**FERRY DRAIN**  
**PROFILE**

**GENERAL NOTES**

- BENCHMARK No.1 ELEV. 198.73m  
 TOP OF SOUTHEAST CORNER OF EXISTING CONCRETE BOX CULVERT CURB CROSSING ROAD 7E, STA. 0+000.

BENCHMARK No.2 ELEV. 198.09m  
 TOP OF WEST END OF EXISTING 1200mm $\phi$  HDPE, CROSSING No.2, STA. 0+241.  
 MN#240
- PROPOSED CROSSING No. 1 INFORMATION:  
 CROSSING No. 1 SHALL BE 18m X 1200mm $\phi$  SANITITE SMOOTH WALL PIPE.  
 ENDWALLS SHALL BE RIP RAP QUARRY STONE 150mm X 300mm, 450mm THICK  
 BACKFILL:  
 CLEAR STONE BEDDING  
 GRANULAR B TYPE 2 BACKFILL  
 100% CRUSHED GRANULAR A TOP
- PROPOSED CROSSING No. 2 INFORMATION:  
 CROSSING No. 2 SHALL BE 18m X 1200mm $\phi$  SANITITE SMOOTH WALL PIPE (FUTURE).  
 PROPOSED TO REPLACED DOWNSTREAM END 6m X 1200mm $\phi$  HDPE SMOOTH WALL PIPE.  
 ENDWALLS SHALL BE RIP RAP QUARRY STONE 150mm X 300mm, 450mm THICK  
 BACKFILL:  
 CLEAR STONE BEDDING  
 GRANULAR B TYPE 2 BACKFILL  
 100% CRUSHED GRANULAR A TOP
- PROPOSED OPEN CHANNEL EXACAVTION:  
 3m UPSTREAM & DOWNSTREAM OF CROSSING No.1 SHALL BE EXCAVATED TO THE PROPOSED GRADE LINE SHOWN ON THE PROFILE.  
 3m DOWNSTREAM OF CROSSING No.2 SHALL BE EXCAVATED TO THE PROPOSED GRADELINE SHOWN ON THE PROFILE.

**NOTE:**  
 ALL GRANULARS COMPACTED TO 98% MODIFIED PROCTOR DENSITY

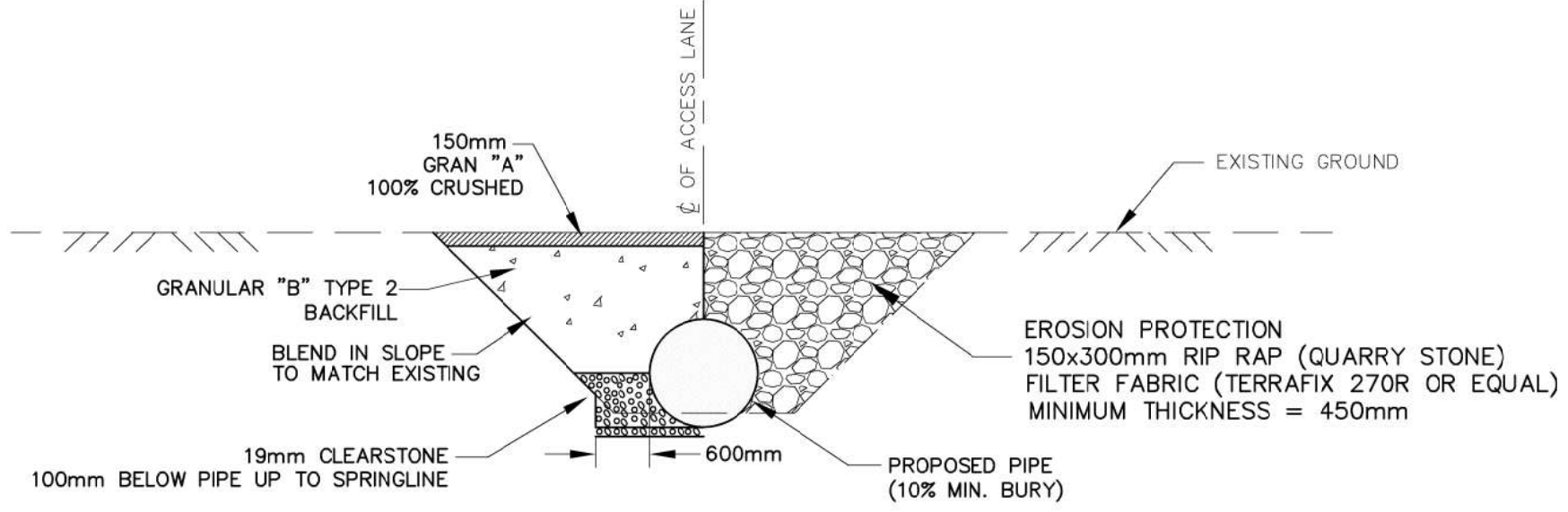

**PROPOSED PIPE END SECTION**

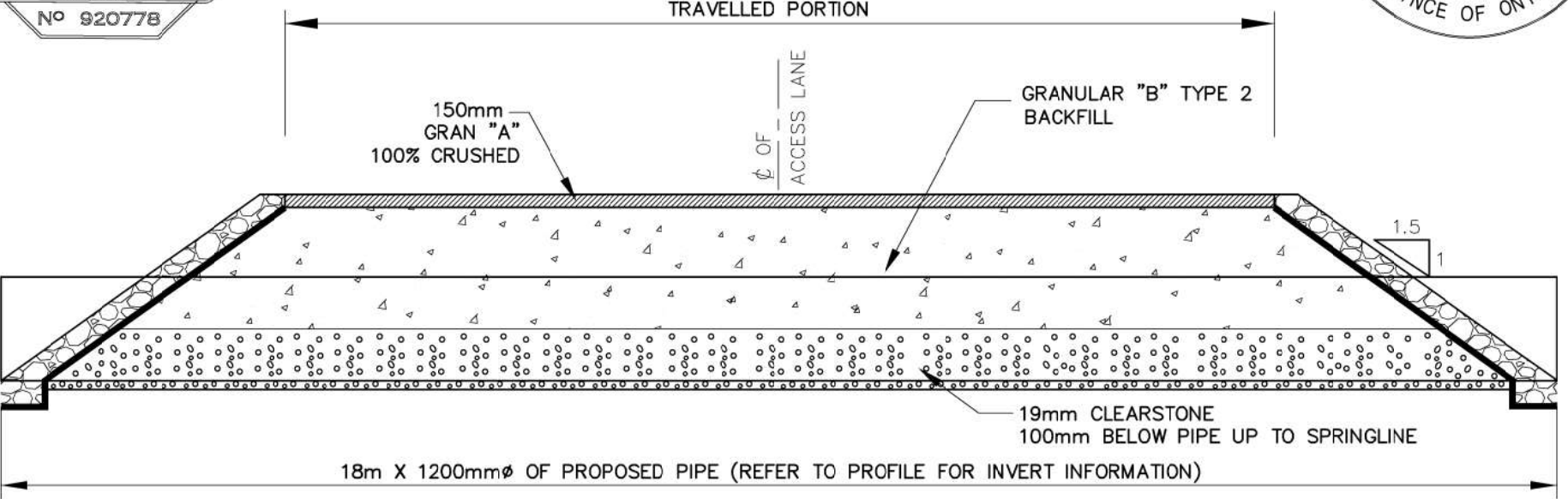
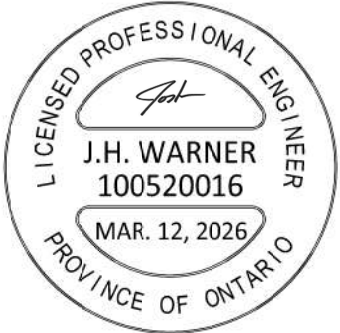

**PROPOSED CROSS-SECTION**



4218 Oil Heritage Road  
 Petrolia Ontario, N0N 1R0  
 Phone: (519) 882-0032 Fax: (519) 882-2233

PROJECT No.  
 2025-1765

APPROVED	J. WARNER	NO.	REVISIONS	DATE	BY
CHECKED	C. SAUNDERS	1	FINAL REPORT	MAR. 12, 2026	DM
DRAWN	D. MOORES	SCALE 1:75			



**TOWN of KINGSVILLE**  
**FERRY DRAIN**  
**TYPICAL CULVERT REPLACEMENT DETAILS**

**3**  
**OF 3**

Last Updated: March 12, 2026

## The Corporation of the Town of Kingsville

**To:** Mayor and Members of Council

**Prepared By:** Lu-Ann Marentette, Drainage Superintendent

**Department:** Planning and Development - Capital Projects and Engineering

**Date of Meeting:** April 20, 2026

**Subject:** Union Water Drain – Request to Abandon the Section 78 Report

---

### Recommended Action

That upon the recommendation from the appointed Drainage Engineer, R.C. Spencer, the Section 78 request to extend the outlet of the Union Water Drain **be abandoned**.

### Background

A letter, along with a Notice of Request for Drain Major Improvements, dated September 21, 2021, was received from three landowners abutting a natural watercourse that runs from County Road 20 to Lake Erie between 1485 and 1495 County Road 20. The landowners (1495 Seacliff Drive West, 2 Buona Vista Drive, and 1467 Wellington Union Avenue) requested a new legal outlet to accommodate stormwater from existing Municipal Drains to the north, under Section 78 of the Drainage Act. Basically, asking that the natural watercourse from County Road 20 to the lake be converted to a Municipal Drain.

As a result, staff brought a report to Council in November of 2022 recommending that Council appoint R.C. Spencer and Associates as the engineer. The recommendation was approved.

Through the appointment of R.C. Spencer, additional investigations of the natural watercourse were completed. It was determined that around 2005, the property at 1491 Lawson Lane was experiencing erosion. This owner, along with the owner of 1467 Wellington Union Avenue, decided to hire an engineer, obtain the necessary approvals from ERCA, and enclosed a large portion of this natural watercourse.

The Permit issued by ERCA to the two landowners in 2010 states that:

*“The works are being proposed to stabilize an eroding ravine that is located adjacent to an existing dwelling. These works have not been designed to satisfy requirements for new development on these properties and do not imply that the proposed works provide adequate protection to your properties from the threat of flooding and erosion.”*

When the natural watercourse was enclosed, several posts were installed in front of the enclosed pipe to collect tree branches as they travelled downstream, preventing them

from entering and blocking the pipe. Continual debris and branch removal from the posts is a challenging, ongoing maintenance issue for 1467 Wellington Union Avenue, which is why this property owner prefers that the Town assumes this natural watercourse as a Municipal Drain.

In and around 2024, the now Drainage Superintendent began reviewing several open / active capital drainage projects, confirming status, legitimacy, etc. The Drainage Superintendent began reviewing this project with the Engineer to understand what the concerns were, versus the current sufficient outlet.

## Discussion

R.C. Spencer reviewed the request to confirm if the existing outlet for the Municipal Drains at County Road 20 is a sufficient outlet. Under the Drainage Act, a sufficient outlet means a point at which water can be discharged safely so that it will do no damage to lands or roads downstream.

R.C. Spencer confirmed the existing outlet is sufficient, as there is currently no property damage or significant erosion south and along the natural watercourse. Engineers are required to take Municipal Drains to a sufficient outlet, and not further, to avoid creating unnecessary costs for those assessed into the Municipal Drains. It was also noted that the enclosure doesn't appear to be up to Municipal Drainage standards as the pipe is potentially too small and thus requiring a collection system for tree branches upstream.

Staff note that a similar project came before Council in 2019, whereby it was declined because the existing Municipal Drains had sufficient outlet into a natural watercourse, and natural watercourses do not need to be designated as Municipal Drains. For the current project, the Drainage Coordinator from OMAFRA at the time noted concerns about how few landowners had requested the work and how the numerous upstream landowners might react to being assessed the costs for preparing a new report and the ongoing maintenance that would follow.

Staff are advising Council to cancel this project for the following reasons:

1. The enclosure isn't built to a Municipal Drainage standard;
2. There is already a sufficient outlet for the existing Municipal Drains;
3. If this were to be a Municipal Drain, it would be very costly to convert to municipal standards.
4. We expect the properties to the north that are assessed into the existing Municipal Drains to appeal this project under the premise that they already have sufficient outlet. Appeals require administrative time and lead to increased costs.
5. Further, there will be significant costs for those along the natural watercourse and we expect them to dispute these costs as well; and
6. The Town is taking on additional risk with this project as a Section 78 as the Drainage Act is relatively silent on how to expense and recover engineering fees for Section 78 projects that do not advance to construction. There is concern that this project could be appealed and ultimately not proceed while engineering fees continue to escalate.

7. Owners can always petition again under Section 4 for a new Municipal Drain. This would be less financial risk to the Town but the appointed engineer will likely arrive at the same conclusion.

In the interests of complete transparency, one senior member of Administration owns a property referenced in this report. This staff member has declared a conflict of interest and is not involved in the decision making for Administration.

### **Financial Considerations**

Approximately \$6,000 was expensed for engineering fees for this project. These costs were expensed to the Capital Drainage Budget.

### **Environmental Considerations**

OMAFRA – Ontario Ministry of Agriculture, Food and Agribusiness

ERCA – Essex Region Conservation Authority

### **Consultations**

Kingsville Administration

R.C. Spencer

### **Prepared By:**



Lu-Ann Marentette  
Drainage Superintendent

**Report Approval Details**

Document Title:	Union Water Drain - Request to Abandon the Section 78 Report.docx
Attachments:	Spencer - Union Water Drain - Letter (2025-10-29).pdf mapforstaffreport.pdf
Final Approval Date:	April 15, 2026

This document and all of its attachments were approved and signed as outlined below:

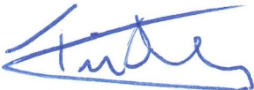

Tim Del Greco, Senior Manager of Capital Projects and Engineering



Richard Wyma, Director of Planning and Development



John Norton, Chief Administrative Officer



29 October 2025  
File No. 23-1400

**Town of Kingsville**  
2021 Division Road North  
Kingsville, ON  
N9Y 2Y9

**Attention: Lu-Ann Marentette**  
**Drainage Superintendent**

**Re: Engineering Services**  
**Drainage Report for the Extension of the Union Water Drain**

Dear Lu-Ann:

The Town of Kingsville appointed RC Spencer Associates Inc. to prepare a drainage report for the Extension of the Union Water Drain pursuant to Section 78 of the Drainage Act.

Section 15 of the Drainage Act requires that every drainage works be continued to a "sufficient outlet," subject to Section 32. The Drainage Act defines a "sufficient outlet" to be a point at which water can be discharged safely so that it will do no damage to lands or roads.

Under Section 78, the Engineer has no authority to continue a drainage works downstream past the point of "sufficient outlet".

On 25 September 2025, I attended a site walkthrough with you and Tim Del Greco (Senior Manager, Capital Projects and Engineering) to review the condition of the natural watercourse, from the downstream end of the Union Water Drain to the Lake Erie outlet. We did not observe any immediate concerns with the condition of the natural watercourse that would necessitate repair and improvement.

Based on our site observations and the condition of the natural watercourse as of 25 September 2025, it is our opinion that downstream extension of the Union Water Drain would not be justified per our appointment under Section 78.

Please reach out if you would like to discuss further.

Sincerely,  
RC SPENCER ASSOCIATES INC.

Share Lafontaine, M.Eng., P.Eng.  
Drainage Engineer

Cc: Dennis McCready  
Marvel Hormiz





## The Corporation of the Town of Kingsville

**To:** Mayor and Members of Council

**Prepared By:** Lu-Ann Marentette, Drainage Superintendent

**Department:** Planning and Development - Capital Projects and Engineering

**Date of Meeting:** April 20, 2026

**Subject:** 3<sup>rd</sup> Concession Branch of the Esseltine Drain – Section 65(3) - 1851 Road 3E

---

### Recommended Action

That the Engineer's Report on the 3<sup>rd</sup> Concession Branch of the Esseltine Drain prepared by R. Dobbin Engineering Inc. and dated January 30, 2026, for a new development at Roll # 290-00113, 1851 Road 3 East, **be adopted;**

And that a buy-in fee into the 3<sup>rd</sup> Concession Branch of the Esseltine Drain **be set** at \$2,963.00;

And that 0.76 hectares be removed from parcel Roll # 290-00113 into the C.O. Branch of the Fleming Wigle Drain.

### Background

The owner of 1851 Road 3 East wishes to take some of their storm water from the C.O. Branch of the Fleming Wigle Drain across the road to the 3<sup>rd</sup> Concession Branch of the Esseltine Drain. The owner had submitted his request for a Section 65(3) report.

### Discussion

The engineering firm of R. Dobbin Engineering reviewed the drains and the parcel and have determined that the runoff from this new development of 0.76 hectares would have little to no effect on the current drainage system for the 3<sup>rd</sup> Concession Branch of the Esseltine Drain.

Therefore, R. Engineering Dobbin has confirmed the feasibility of removing 0.76 hectares from the C.O. Branch of the Fleming Wigle Drain and adding to the 3<sup>rd</sup> Concession Branch of the Esseltine Drain.

The following reports will require amendments to the schedules:

- 3<sup>rd</sup> Concession Branch of the Esseltine Drain dated March 7, 1997 (connected)
- Esseltine Drain dated September 8, 1996 (connected)
- Esseltine Drain dated June 17, 2016 (connected)
- C.O. Branch of the Fleming Wigle Drain dated May 29, 1988 (disconnected)

As well, a subsequent connection or buy in fee will be required on the Esseltine Drain, as this would have been their cost during the project in 2016 if they were assessed at that time.

**Financial Considerations**

That the owner of Roll # 290-00113 be invoiced for the following:

Buy-In Fee                \$2,963.00

Cost of Report        \$4,035.00

**Environmental Considerations**

N/A

**Consultations**

R. Dobbin Engineering

**Prepared By:**



Lu-Ann Marentette  
Drainage Superintendent

**Report Approval Details**

Document Title:	3rd Concession Branch of the Esseltine Drain - Section 65(3) - 1851 Road 3E .docx
Attachments:	3rd Conc Br of Esseltine Drain - Sec 65 - Revised Jan 30 2026.pdf
Final Approval Date:	April 15, 2026

This document and all of its attachments were approved and signed as outlined below:

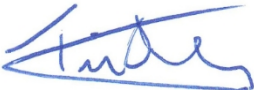

Tim Del Greco, Senior Manager of Capital Projects and Engineering



Richard Wyma, Director of Planning and Development



John Norton, Chief Administrative Officer

January 30, 2026

The Mayor and Council  
Town of Kingsville  
2021 Division Road North  
Kingsville, Ontario  
N9Y 2Y9

**Re: Request for Section 65(3) Subsequent Connection to the 3<sup>rd</sup> Concession  
Branch of the Esseltine Drain**

In accordance with your instructions, we have undertaken an examination of a subsequent connection to the 3<sup>rd</sup> Concession Branch of the Esseltine Drain located in Lots 10 & 11, Concession 3 E.D, in the Town of Kingsville.

Authorization under the Drainage Act

This Engineers Report has been prepared under Section 65(1), Section 65(3), and 65(4) of the Drainage Act.

**Subsequent subdivision of land**

65(1) If, after the final revision of an engineer's assessment of land for a drainage works, the land is divided by a change in ownership of any part, the clerk of the local municipality in which the land is situate shall instruct an engineer in writing to apportion the assessment among parts into which the land was divided, taking into account the part of the land affected by the drainage works. 2010, c. 16, Sched. 1, s. 2 (26).

**Subsequent connection to drainage works, etc.**

65(3) If an owner of land that is not assessed for a drainage works subsequently connects the land with the drainage works for the purpose of drainage, or if the nature or extent of the use of a drainage works by land assessed for the drainage works is subsequently altered, the clerk of the local municipality in which the land is situate shall instruct an engineer in writing to inspect the land and assess it for a just proportion of the drainage works, taking into account any compensation paid to the owner of the land in respect of the drainage works. 2010, c. 16, Sched. 1, s. 2 (26).

**Subsequent disconnection from drainage works**

65(4) If an owner of land that is assessed for a drainage works subsequently disconnects the land from the drainage works, the clerk of the local municipality in which the land is situate

shall instruct an engineer in writing to inspect the land and determine the amount by which the assessment of the land should change. 2010, c. 16, Sched. 1, s. 2 (26).

The owner of Loesen Farms Inc. (roll no. 290-00113) submitted a request to direct 0.76 ha to the 3<sup>rd</sup> Concession Branch of the Esseltine Drain which is currently assessed to the C&O Branch of the Fleming Wigle Drain.

R. Dobbin Engineering was appointed on November 4, 2025.

### Existing Drainage

The 3<sup>rd</sup> Concession Branch of the Esseltine Drain outlets into the Esseltine Drain at the southwest corner of County Road 34 and Road 3E. The drain heads upstream along the south side of Road 3E as a closed drain for approximately 84 meters, where it crosses to the north side and continues as a closed drain for another 146 meters. From this point, it becomes an open channel drain and continues upstream for approximately 845 meters to the head of the drain.

The current governing report and Bylaw for the drain is Bylaw No. 14 of 1997 and Engineer's Report dated March 7, 1997 prepared by N.J. Peralta, P.Eng.

### Review and Investigation

In preparation of our report under Section 65, the following reports were reviewed:

- 3<sup>rd</sup> Concession Branch of the Esseltine Drain dated March 7, 1997 and Bylaw 14-1997 by N.J. Peralta, P.Eng.
- 3<sup>rd</sup> Concession Branch of the Esseltine Drain dated September 2, 1952 and Bylaw 226-1952 by C.G.R. Armstrong, P.Eng.
- Esseltine Drain dated September 8, 1966 and Bylaw 313-1966 by William J. Setterington, P.Eng.
- Esseltine Drain dated June 17, 2016 and Bylaw 93-2017 by Lou Zarlenga, P.Eng. from RC Spencer Associates Inc.
- Colasanti Branch of the Esseltine Drain dated September 10, 2004 and Bylaw 31-2005 by N.J. Peralta, P.Eng.
- C&O Branch of the Fleming Wigle Drain dated May 29, 1988 and Bylaw 526-1988 by Lou Zarlenga, P.Eng. from Bruce D. Crozier Engineering.
- Fleming Wigle Drain dated June 1, 1971 and Bylaw 371-1971 by William J. Setterington, P.Eng.

Along with review of the above reports, the stormwater drawings prepared by Baird Architecture & Engineering dated August 25, 2025 were reviewed.

Our investigation involved determining the existing watershed for the 3<sup>rd</sup> Concession Branch of the Esseltine Drain. We used this watershed along with current runoff coefficients outlined in the Windsor/Essex Region Stormwater Manual to calculate the capacity and flows at each culvert and drain enclosure on the drain. The existing capacity and flows were compared against the request to add 0.76 ha with a restricted runoff rate 2.6 L/sec from 1851 Road 3E (roll no. 290-00113). We found that the additional area would have little to no effect on the current drainage system for the 3<sup>rd</sup> Concession Branch of the Esseltine Drain.

Connection / Disconnection Location

The location to be added and removed is shown below. An area of 0.76 ha will be subsequently removed from the C&O Branch of the Fleming Wigle Drain and added to the 3<sup>rd</sup> Concession Branch of the Esseltine Drain.



As part of this connection and disconnection we revised the schedules contained in the following reports for maintenance purposes:

- 3<sup>rd</sup> Concession Branch of the Esseltine Drain date March 7, 1997 (connected)
- Esseltine Drain dated September 8, 1966 (connected)
- Esseltine Drain dated June 17, 2016 (connected)

- C&O Branch of the Fleming Wigle Drain dated May 29, 1988 (disconnected)

The C&O Branch of the Fleming report required a Section 65(1) to reappportion the assessments, as properties had been subdivided and/or combined with new roll numbers created.

The current governing reports on the Fleming Wigle Drain were not revised as part of this report. Due to the significant changes in the watershed, a Section 76 report is required.

Appendix A attached contains all updated schedules.

Recommendations

As established in this report, we recommend that the Town of Kingsville accept the revised drainage assessments for maintenance purposes as outlined in Appendix A for each drain affected. The updated assessment for roll no. 290-00113 was derived by comparing assessments of properties in the vicinity of the added land and by using a land use of Agricultural – Greenhouse for the additional area.

As per Section 65(12), “any amount collected under subsection (3) shall be credited to the account of the drainage works and shall be used only for the improvement, maintenance or repair of the whole or any part of the drainage works”. 2010, c. 16, Sched. 1, s. 2 (26).

Therefore, we have established that a subsequent connection fee of \$2,963.00, known as a “buy in”, be applied to the Esseltine Drain, as this would have been the additional cost assessed to property for the work completed under the June 17, 2016 report. This amount was determined using the final construction cost for the works and by applying the 1/3 subsidy for an agricultural grant. No other fees shall be collected for the purpose of buying into any other drains.

The total engineering cost to complete this report is \$4,035.00, excluding HST. This shall be assessed 100% to the parcel with roll no. 290-00113.

Yours truly,

Report Prepared By:

*DM*

David Moores, C.E.T.



Report Approved By:

*JH*

Josh Warner, P. Eng.

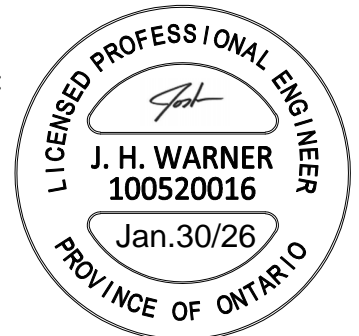

**APPENDIX A**

Roll No. 290-00113  
 Town of Kingsville  
 January 30, 2026

As per Section 65(3) & 65(4) of the Drainage Act, we recommend that the Schedule of Assessment for maintenance purposes be apportioned as follows:

Conc.	Lot or pt. Lot	Roll No.	Hect.	Owner	Benefit	Outlet	Total
-------	-------------------	----------	-------	-------	---------	--------	-------

**Third Concession Branch of the Esseltine Drain dated March 7, 1997**

Original Assessment

2 E.D. pt. Lot 11	290-00113	0.00	Loesen Farms Inc.	0.00	0.00	0.00
-------------------	-----------	------	-------------------	------	------	------

Updated Assessment

2 E.D. pt. Lot 11	290-00113	0.76	Loesen Farms Inc.	\$ 780.00	\$ 1,175.00	\$ 1,955.00
-------------------	-----------	------	-------------------	-----------	-------------	-------------

Original Total Assessment less Special Benefit	\$	35,301.00
Updated Total Assessment less Special Benefit	\$	37,256.00

**Esseltine Drain dated September 8, 1966**

Original Assessment

2 E.D. pt. Lot 11	290-00113	0.00	Loesen Farms Inc.	0.00	0.00	0.00
-------------------	-----------	------	-------------------	------	------	------

Updated Assessment

2 E.D. pt. Lot 11	290-00113	0.76	Loesen Farms Inc.	\$ 40.00	\$ 20.00	\$ 60.00
-------------------	-----------	------	-------------------	----------	----------	----------

Original Total Assessment	\$	4,095.00
Updated Total Assessment	\$	4,155.00

**Esseltine Drain dated June 17, 2016**

Original Assessment

2 E.D. pt. Lot 11	290-27000	1.74	Loesen Farms Inc.	0.00	\$ 3,012.00	\$ 3,012.00
-------------------	-----------	------	-------------------	------	-------------	-------------

Updated Assessment

2 E.D. pt. Lot 11	290-00113	2.50	Loesen Farms Inc.	0.00	\$ 6,312.00	\$ 6,312.00
-------------------	-----------	------	-------------------	------	-------------	-------------

Original Total Assessment less Special Benefit	\$	3,954,699.00
Updated Total Assessment less Special Benefit	\$	3,957,999.00

Buy in amount:	\$	4,490.00
Buy in amount (Applying grant):	\$	2,963.00

Roll No. 290-00113  
 Town of Kingsville  
 December 12, 2025

As per Section 65(1) & 65(4) of the Drainage Act, we recommend that the Schedule of Assessment for maintenance purposes be apportioned as follows:

Conc.	Lot or pt. Lot	Roll No.	Hect.	Owner	Benefit	Outlet	Total
<b>Chesapeake &amp; Ohio Branch of the Fleming Wigle Drain dated May 29, 1988</b>							
Original Assessment							
2 E.D.	pt. Lot 12 & 13	3-264	14.04	County of Essex	\$ 1,148.00	\$ 1,185.00	\$ 2,333.00
2 E.D.	pt. Lot 12	3-246	9.71	Frank & Lorenzina Ricci	\$ 785.00	\$ 621.00	\$ 1,406.00
2 E.D.	pt. Lot 11 & 12	3-269	10.93	Roberto Michelutti	\$ -	\$ 590.00	\$ 590.00
2 E.D.	pt. Lot 11 & 12	3-270	11.64	John & Marie Bailey	\$ 375.00	\$ 570.00	\$ 945.00
2 E.D.	pt. Lot 11	3-233-01	2.83	Eric Zimmer	\$ -	\$ 142.00	\$ 142.00
2 E.D.	pt. Lot 11 & 12	3-242	0.20	Mary Fotheringham	\$ 70.00	\$ -	\$ 70.00
2 E.D.	pt. Lot 11 & 12		1.38	Chesapeake & Ohio Railway	\$ 152.00	\$ 527.00	\$ 679.00
			50.73		\$ 2,530.00	\$ 3,635.00	\$ 6,165.00
Updated Assessment							
2 E.D.	pt. Lot 12 & 13	290-264	14.04	County of Essex	\$ 1,148.00	\$ 1,185.00	\$ 2,333.00
2 E.D.	pt. Lot 11	290-00113	9.33	Loesen Farms Inc.	\$ -	\$ 511.00	\$ 511.00
2 E.D.	pt. Lot 11 & 12	290-26951	23.62	Bull Market Farms Inc.	\$ 1,160.00	\$ 1,294.00	\$ 2,454.00
2 E.D.	pt. Lot 11	290-23301	1.40	Loesen Farms Inc.	\$ -	\$ 77.00	\$ 77.00
2 E.D.	pt. Lot 11 & 12	290-242	0.20	Sarah & Neil Fotheringham	\$ 70.00	\$ -	\$ 70.00
2 E.D.	pt. Lot 11 & 12		1.38	Chesapeake & Ohio Railway	\$ 152.00	\$ 527.00	\$ 679.00
			49.97		\$ 2,530.00	\$ 3,594.00	\$ 6,124.00

## The Corporation of the Town of Kingsville

**To:** Mayor and Members of Council

**Prepared By:** Angela Toole, Manager of Municipal Governance/Clerk

**Department:** Finance and Corporate Services - Municipal Governance

**Date of Meeting:** April 20, 2026

**Subject:** Proposal to Establish a Joint Election Compliance Audit Committee with Local Municipalities

---

### Recommended Action

That a Joint Election Compliance Audit Committee **be established** for the 2026-2030 Term of Council;

And that the Terms of Reference for the Joint Election Compliance Audit Committee, attached hereto as Schedule A, **be adopted**;

And that By-law 30-2026 being a By-law to Establish a Joint Election Compliance Audit Committee **be adopted** during the By-law stage of this Agenda.

### Background

The *Municipal Elections Act, 1996* (“MEA”) requires municipalities to establish an Election Compliance Audit Committee (hereafter, “Committee”) prior to October 1st in the year of an election to deal with matters regarding election campaign finances and contributions.

Section 88.33 of the MEA permits an elector who believes, on reasonable grounds, that a Candidate or a Registered Third Party has contravened a provision of the MEA relating to election campaign finances to apply for a compliance audit of the Candidate’s or Registered Third Party’s election campaign finances.

The Committee’s mandate is to determine whether a request for a compliance audit should be granted or rejected. If the Committee grants the request, then the Committee is required by the MEA to appoint an Auditor to conduct a compliance audit of the Candidate or Registered Third Party’s election campaign finances. The Auditor is then required to audit the election campaign finances, subject of the granted request, to determine whether they have complied with the provisions of the MEA respecting campaign finances. At the conclusion of the audit, the Auditor provides a report to the Committee stating their findings.

## Discussion

The mandate of the Election Compliance Audit Committee is considered complete at the end of each four-year term of Council at which time a successor Committee must be appointed. As such, it is necessary to establish and appoint a Committee for the 2026-2030 Term of Council. The MEA specifies that Election Compliance Audit Committees shall be composed of between three (3) and seven (7) members and shall not include:

1. Employees or Officers of the municipality or local board;
2. Members of Council or a local board;
3. Any persons who are Candidates in the election for which the Committee is established; or,
4. Any persons who are Registered Third Parties in the municipality in the election for which the Committee is established.

An increasingly common practice across Ontario municipalities is to establish Joint Election Compliance Audit Committees. These Joint Committees are comprised of several municipalities which are geographically located in upper-tier municipalities. For example, the County of Middlesex, County of Elgin, County of Simcoe, Regional Municipality of Halton, Regional Municipality of York, and Regional Municipality of Niagara have each established Joint Election Compliance Audit Committees in past elections, and will continue to engage in this practice for the 2026 Municipal Elections.

The benefits to establishing a Joint Election Compliance Audit Committee can be summarized below:

- Shared membership allows municipalities to access a broader pool of qualified applicants from across Essex County;
- Representation from multiple municipalities promotes balanced decision-making and shared responsibility;
- Members from outside the municipality enhance objectivity and impartiality, reducing real or perceived bias;
- Compliance audit requests are rare, with none received in the most recent election; and,
- A joint approach is therefore cost-effective and minimizes administrative duplication while maintaining readiness.

Administration is recommending that Council establish a Joint Election Compliance Audit Committee together with the Town of Essex, Town of Kingsville, Municipality of

Lakeshore, Town of Lasalle, and Town of Tecumseh for the 2026-2030 Term of Council. The Committee will operate pursuant to the Terms of Reference attached as Schedule 'A' to By-law 30-2026. The Committee will be composed of five (5) members, and one (1) alternate. Selection will be based on the following criteria, with a preference given to those persons who have demonstrated experience in public accounting, auditing, legal and the application of campaign finance rules:

1. Demonstrated knowledge and understanding of municipal election campaign financing rules;
2. Proven analytical and decision-making skills;
3. Experience working on a committee, task force, or similar setting;
4. Availability and willingness to attend meetings; and,
5. Excellent oral and written communication skills.

Recruitment will begin once the Councils of each member municipality have adopted the requisite establishing By-law and Terms of Reference.

At the time of this Report, the Councils of the Town of Amherstburg, Town of LaSalle, and Town of Tecumseh, have all adopted By-laws authorizing the establishment of a Joint Election Compliance Audit Committee.

### **Financial Considerations**

In accordance with Section 88.37(7) of the MEA, it is the responsibility of the municipality to cover all costs in relation to the Committee's operations and activities. Costs may include:

- General costs associated with the Committee's operations (advertising, training, remuneration);
- Cost and choice of the Auditor for any audit that takes place; and,
- Cost and choice of external legal counsel for the Committee, if necessary.

Administration has surveyed other municipalities and determined that the average compensation is \$150.00 per member, per meeting, plus mileage based on current Canada Revenue Agency rates. These costs will be shared amongst all Member Municipalities.

The responding Member Municipality shall pay all other costs related to a respective Application, including the retention of an Auditor or external legal counsel, if necessary, in accordance with Section 88.37(7) of the Act.

**Environmental Considerations**

None.

**Consultations**

Natalie Sharp, Supervisor of Municipal Governance/Deputy Clerk

**Prepared By:**



Angela Toole, B.A. (Hons), B. Ed.  
Manager of Municipal Governance/Clerk

**Report Approval Details**

Document Title:	Joint Election Compliance Audit Committee.docx
Attachments:	xx-2026 Establish a Joint Election Compliance Audit Committee.dotx.docx Joint Election Compliance Audit Committee Terms of Reference_draft.docx
Final Approval Date:	April 15, 2026

This document and all of its attachments were approved and signed as outlined below:



Angela Toole, Manager of Municipal Governance/Clerk  
**No Signature - Task assigned to Ryan McLeod, Director of Finance and Corporate Services/Treasurer was completed by Meeting Administrator Natalie Sharp, Supervisor of Municipal Governance/Deputy Clerk**  
Ryan McLeod, Director of Finance and Corporate Services/Treasurer



John Norton, Chief Administrative Officer

# The Corporation of the Town of Kingsville

## By-law XX-2026

---

### Being a By-law to authorize the establishment of a Joint Election Compliance Audit Committee

**Whereas** Sections 8 and 9 of the *Municipal Act, 2001* S.O. 2001 c. 25, as amended, (the "Act") provides that a municipality has the capacity, rights, powers and privileges of a natural person for the purpose of exercising the authority conferred upon a municipality to govern its affairs as it considers appropriate;

**And whereas** Section 88.37(1) of the Municipal Elections Act, 1996, as amended (the Act), provides that a Council or local board shall, before October 1 of an election year, establish a compliance audit committee for the purposes of the Act;

**And whereas** Section 88.37(6) of the Municipal Elections Act, 1996, as amended, states that the Clerk of the municipality or the secretary of the local board, as the case may be, shall establish administrative practices and procedures for the committee and shall carry out any other duties required under this Act to implement the committee's decisions;

**And whereas** the Town of Amherstburg, Town of Essex, Town of Kingsville, Municipality of Lakeshore, Town of Lasalle, and Town of Tecumseh deem it expedient to establish a Joint Election Compliance Audit Committee for the purposes of the Act.

**Now therefore The Council of the Corporation of the Town of Kingsville enacts as follows:**

1. **That** a Committee to be known as the Joint Election Compliance Audit Committee, is hereby established to deal with the matters provided for in Sections 88.33, 88.34, 88.35, and 88.36 of the Act for the 2026-2030 term of Council;
2. **That** the business of the Joint Election Compliance Audit Committee be conducted in accordance with the Terms of Reference set out in Schedule "A" attached hereto and forming a part of this By-law; and
3. **That** this By-law comes into force and takes effect on the day of the final passing thereof.

**Read a first, second and third time and finally passed this 20<sup>th</sup> day of April, 2026.**

---

Mayor, Dennis Rogers

---

Clerk, Angela Toole



essex

Kingsville  
ONTARIO



## Schedule “A”

### Terms of Reference - Joint Election Compliance Audit Committee

#### Name

This “Committee” shall be known as the “Joint Election Compliance Audit Committee”

#### Definitions

“Act” means the *Municipal Elections Act, 1996*, as amended.

“Applicant” means an elector who makes an Application pursuant to Section 88.33 of the Act.

“Application” means an Application for a compliance audit properly completed and submitted to the Clerk pursuant to Section 88.33(2) of the Act.

“Auditor” means a person appointed by the Joint Election Compliance Audit Committee, licensed under the *Public Accounting Act, 2004*, to conduct a compliance audit of a Candidate or Registered Third Party Advertiser financial statements.

“Candidate” means the candidate whose election campaign finances are the subject of an Application for a compliance audit.

“Clerk” means the Municipal Clerk of a Member Municipality, as appointed under Section 228 of the *Municipal Act, 2001*, or their designate.

“Member Municipality” refers to the participating municipalities which include the Town of Amherstburg, Town of Essex, Town of Kingsville, Municipality of Lakeshore, Town of LaSalle, and Town of Tecumseh.

“Registered Third Party Advertiser” means the individual, corporation, or trade union whose notice of registration has been certified by the Clerk and whose campaign finances are the subject of an Application for a compliance audit.

#### Mandate

The Committee shall operate in accordance with the powers and functions as outlined under Sections 88.33 to 88.37 of the Act. These functions include:

- a) Considering whether an Application for a compliance audit of a Candidate's election campaign finances or for a compliance audit of a Third Party Advertiser's campaign expenses should be granted or rejected;
- b) Appointing an Auditor if the Application is granted;
- c) Receiving and considering the Auditor's report and directing Administration whether legal proceedings should be commenced against the Candidate;
- d) Receiving and considering any reports from the Clerk identifying contributors to a Candidate and/or Registered Third Party Advertiser who appear to have contravened election contribution limits and directing Administration whether legal proceedings should be commenced against the Contributor; and,
- e) Issuing brief written reasons for all decisions made by the Committee.

### **Term**

The term of office of the Committee is the same as the term of office of the Council elected following the next regular election, in accordance with Section 88.37(5) of the Act. Should an Application extend beyond the term of office of Council, Committee Members shall continue to fulfill the mandate of the Committee until such time that a new Committee has been appointed.

### **Committee Composition and Member Qualifications**

The Committee shall be composed of five (5) members and one (1) alternate member from the public with demonstrated experience in one or more of the following areas:

- a) Accounting and Audit – accountants or auditors with experience in preparing or auditing the financial statements of municipal Candidates;
- b) Legal – lawyers or other legal professionals;
- c) Academia – college or university professors with expertise in political science or local government administration;
- d) Municipal Governance and Elections – individuals with experience in government administration or experience and knowledge of the campaign financing rules of the Act.

Committee members shall not include:

- a) Employees or officers of a Member Municipality or their local boards;
- b) Members of Council or local boards in a Member Municipality;
- c) Any persons who are Candidates in the election for which the Committee is established; or
- d) Any persons who are associated with a Registered Third Party Advertiser in a Member Municipality during the election for which the Committee is established.

All applicants will be required to submit a completed application form outlining their qualifications and experience. The Clerks of the Member Municipalities shall review all applications and appoint members to the Committee. Committee members will be selected based on the following criteria:

- a) Demonstrated knowledge and understanding of municipal election campaign financing rules;
- b) Proven analytical and decision-making skills;
- c) Experience working on a committee, task force, or similar setting;
- d) Availability and willingness to attend meetings; and,
- e) Excellent oral and written communication skills.

### **Meetings**

The Committee will meet as needed, with meetings to be scheduled by the Clerk of the Member Municipality where an Application is received and in accordance with the requirements of the Act. The Clerk of the responding Member Municipality shall act as Recording Secretary to the Committee, with respect to the relevant Application.

The Clerk of the responding Member Municipality shall establish administrative practices and procedures for the Committee and shall carry out any other duties required under the Act to implement the Committee's decisions, in accordance with Section 88.37(7) of the Act. Where the procedure is silent, the meeting shall be conducted in accordance with the Procedural By-Law of the responding Member Municipality.

All meetings of the Committee shall be open to the public, but the Committee may deliberate in private, pursuant to Section 88.36(6.1) of the Act.

### **Conflict of Interest**

Committee members shall comply with the *Municipal Conflict of Interest Act, 1990* and shall disclose the pecuniary interest to the Recording Secretary in advance of any Committee meeting, where possible, or absent themselves from Committee meetings for the duration of the discussion and voting with respect to such matter in which the Committee member has a conflict.

In the event a Committee member discloses a pecuniary interest in the Application in advance of the Committee meeting, the Committee member shall be replaced with the alternate Committee member.

To avoid possible conflicts of interest, all Committee members shall agree in writing that they will not work or volunteer for, or contribute to, any Candidate or Registered Third Party Advertiser in any capacity in an election which the Committee is established. Contravention of this requirement shall result in removal from the Committee.

**Expenses**

Committee members shall be paid a per diem rate of \$150.00, plus mileage in accordance with the Canadian Revenue Agency's Directive on Travel.

Costs associated with training shall be shared equally among Member Municipalities. The responding Member Municipality shall pay all other costs related to the respective Application, including the retention of an Auditor or external legal counsel, if necessary, in accordance with Section 88.37(7) of the Act.

## The Corporation of the Town of Kingsville

**To:** Mayor and Members of Council

**Prepared By:** Vicky Sawatzky, Supervisor of Tax Revenue

**Department:** Finance and Corporate Services - Financial Services

**Date of Meeting:** April 20, 2026

**Subject:** 2026 Tax Rates and Final Tax Levy By-law

---

### Recommended Action

That By-law 29-2026, being a By-law to provide for the establishment of the tax rates for the Town of Kingsville for the year 2026 and to provide for the final tax levy, **be adopted** during the By-law stage of this Council Agenda.

### Background

In accordance with Section 312 (2) of the *Municipal Act, 2001*, each year Council must authorize a by-law to establish rates for the levy and collection of property taxes.

In addition to establishing and collecting its own taxes, the Town is also responsible for levying and collecting property taxes on behalf of the County of Essex and the Ministry of Education

### Discussion

The total tax rate for each property tax class is comprised of three separate components:

1. Town of Kingsville (Lower Tier Municipal) rate
2. County of Essex (Upper Tier Municipal) rate
3. Education rate

The Town of Kingsville tax rates are based on the following factors:

- the amount to be levied, as per the approved municipal budget
- the assessment roll for the tax year, as provided by MPAC
- the tax class ratios, as established by the County of Essex

The Town of Kingsville approved its 2026 municipal budget on December 10, 2025. On January 19, 2026, By-law 03-2026 was adopted for the establishment of the 2026 Town of Kingsville tax rates.

The County tax rates are established annually by County Council. For 2026, these rates are provided in County of Essex By-law 2026-05.

The Education tax rates are prescribed annually by the Ministry of Finance.

On a combined basis, the Town, County, and Education tax rates have increased by 4.0% over 2025. For the average residential dwelling, assessed at \$250,000, this amounts to an increase of \$155.83. A breakdown of the allocation of tax dollars is noted below.

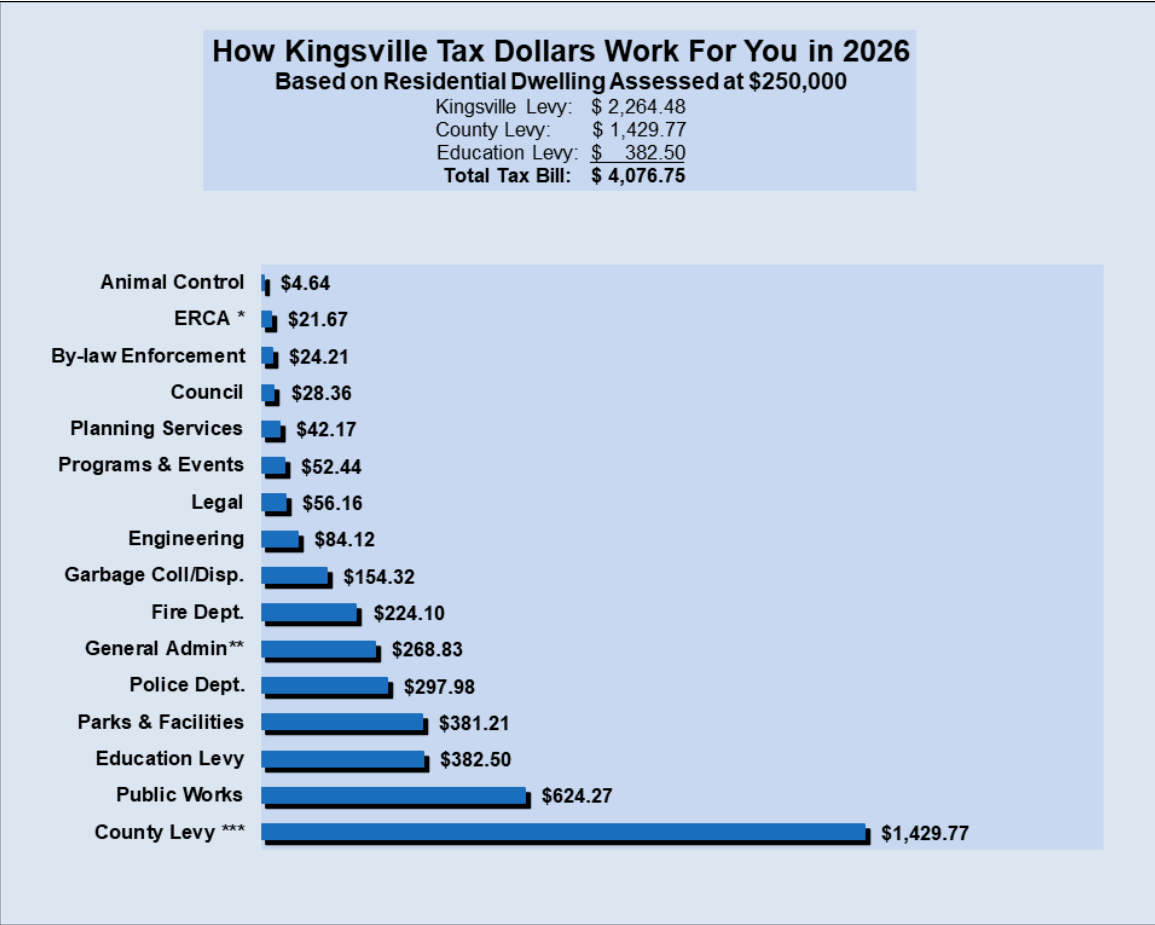

\* Essex Region Conservation Authority

\*\*General Admin includes: CAO Office, Economic Development, Finance, Human Resources, Communications, Clerks & Information Technology

\*\*\* County levy spent on: County Roads, Libraries, Social Services, Ambulance, etc.

The final tax notices will be issued in July and have due dates of August 31<sup>st</sup> and November 30<sup>th</sup>.

**Financial Considerations**

Based on the current year assessment roll as provided by MPAC, the municipal tax rates will raise \$27,210,839 as approved in the 2026 municipal budget.

**Environmental Considerations**

There are no environmental considerations associated with this report.

**Consultations**

The assessment values and tax classes for all properties are provided by Municipal Property Assessment Corporation

**Prepared By:**



Vicky Sawatzky, BBA  
Supervisor of Tax Revenue

**Report Approval Details**

Document Title:	2026 Tax Rates and Final Tax Levy By-Law.docx
Attachments:	XX-2026 Final Tax Levy and 2026 Tax Rates.pdf Schedule A.pdf Schedule B.pdf Schedule C.pdf
Final Approval Date:	April 15, 2026

This document and all of its attachments were approved and signed as outlined below:



Margaret Schroeder, Manager of Financial Services/Deputy Treasurer



Ryan McLeod, Director of Finance and Corporate Services/Treasurer



John Norton, Chief Administrative Officer

## The Corporation of the Town of Kingsville

### By-law xx-2026

---

**Being a By-law to provide for the establishment of rates for the levy and collection of property taxes in the Town of Kingsville for the year 2026 pursuant to the provisions of the Municipal Act.**

**Whereas** the Council of the Corporation of the Town of Kingsville has reviewed its estimates for the year 2026;

**And whereas** Section 290 (1) of *the Municipal Act, 2001*, S.O. 2001 c. 25, as amended, provides that the Council of a local municipality shall in each year prepare and adopt a budget including the estimates of all sums required during the year for the purposes of the municipality;

**And whereas** the Council of the Corporation of the Town of Kingsville has approved the 2026 Town of Kingsville estimates in accordance with Schedule "A" attached hereto;

**And whereas** pursuant to the Corporation of the County of Essex By-law 2026-05, the Corporation of the County of Essex passed a by-law to adopt estimates of all sums required during the year 2026 for the Corporation of the County of Essex and to establish tax rates for same against the local municipalities;

**And whereas** Section 312 (2) of *the Municipal Act, 2001*, S.O. 2001, c. 25, as amended, provides that the Council of a local municipality shall, after the adoption of estimates for the year, pass a by-law to levy a separate tax rate, as specified in the by-law, on the assessment in each property class in the municipality ratable for local municipal purposes;

**And whereas** Section 312 (6) of the said Act requires tax rates to be established in the same proportion to tax ratios;

**And whereas** The Corporation of the County of Essex passed By-law 2026-05, being a by-law to establish tax ratios for 2026 for the Corporation of the County of Essex and the lower tier municipalities within the boundaries of the County of Essex, pursuant to Section 308 of *the Municipal Act, 2001*, S.O. 2001, c. 25 as amended;

**And whereas** Sections 315 and 322 of *the Municipal Act, 2001*, S.O. 2001, c.25, as amended, provide for the apportionment of payments in lieu of taxes and taxation of certain railway and power utility lands.

**Now therefore The Council of the Corporation of the Town of Kingsville enacts as follows:**

1. That the 2026 assessment per property class as detailed in Schedule "B" attached hereto and forming part of this by-law, be adopted for purposes of calculating the tax rates for municipal purposes and for determining the levy for the Town of Kingsville.
2. That the amount to be raised by tax rates for the Town of Kingsville purposes in the amount of \$27,210,839 as set out in Schedule "A" attached hereto and forming part of this by-law be adopted.
3. That the tax rates as listed in Schedule "C" attached to this by-law be applied to the corresponding taxable assessments listed in Schedule "B" to raise sums of, \$27,210,839 for general Town purposes; \$17,180,579 for the County of Essex; and \$6,672,256 for education purposes.
4. That the levies listed in clause (3) of this by-law shall be reduced by the amount of the interim levy for 2026.

5. That the 2026 final tax demand be levied in two (2) installments which will be due and payable on **August 31, 2026** and **November 30, 2026**.
6. That amounts to be collected for local improvements, tile drains, municipal drains, water mains, sewers and miscellaneous charges shall be collected in accordance with their respective authorizing by-laws and are deemed to be imposed and due on the installment due dates listed in clause (5) of this by-law.
7. That the Treasurer and/or Tax Collector, no later than twenty one (21) days prior to the day the first installment is due, may mail or cause to be mailed to the address of the residence or place of business of each person taxed as aforesaid, a notice specifying the amount of taxes payable by such person/corporation.
8. That pursuant to Section 345 (2) of the *Municipal Act, 2001*, S.O. 2001, C.25, as amended, 1 ¼ per cent of the amount of taxes due and unpaid, shall be imposed as a penalty for the non-payment of taxes on the first day of default.
9. That pursuant to Section 345 (3) of the *Municipal Act, 2001*, S.O. 2001, c. 25, as amended, 1 ¼ per cent shall be imposed on outstanding taxes on the first day of the calendar month after payment default and each calendar month thereafter. No discount shall be allowed for pre-payment.
10. That failure to receive a tax notice does not exempt the property owner from penalty and late payment charges as outlined in clauses (8) and (9) of this by-law.
11. Council reserves the right to waive or reduce the penalty and interest calculations outlined in clauses (8) and (9), for specified periods of time, through an approved motion of Council. Any such waivers or reductions shall be applied consistently, to all property classes.
12. That taxes shall be payable to The Corporation of the Town of Kingsville at 2021 Division Road North, Kingsville, ON or paid at any financial institution which is authorized to accept payment under the Canadian Payments Association Regulations.
13. That the Treasurer and/or Tax Collector shall hereby be authorized to administer a pre-authorized payment plan for the Town of Kingsville and accept four (4) quarterly due date or twelve (12) monthly payments on account of taxes due.
14. This By-law shall remain in force from year to year until it is repealed and any By-law repealing this by-law shall be effective only at the end of any year.
15. In the event of conflict between the provisions of this By-law and any other By-law, the provisions of this By-law shall prevail.
16. This By-law shall come into force and take effect on the day of the final passing thereof.

**Read a first, second and third time and finally passed this 20<sup>th</sup> day of April, 2026.**

---

**MAYOR, Dennis Rogers**

---

**ACTING CLERK, Angela Toole**

**Consolidated Budget Summary**

<b>Taxation</b>	<b>2025 Budget</b>	<b>2026 Budget</b>
Taxation Levy	\$ 25,459,458	\$ 27,210,839
Supplemental & Other Taxes	\$ 390,000	\$ 390,000
<b>Total Taxation:</b>	<b>\$ 25,849,458</b>	<b>\$ 27,600,839</b>

<b>Operations</b>	<b>2025 Budget</b>	<b>2026 Budget</b>
<b>Operating Revenue:</b>		
Council	\$ -	\$ -
Financial Services	\$ 1,901,900	\$ 2,050,400
CAO Dept	\$ -	\$ -
Clerks	\$ 202,700	\$ 64,450
Legal	\$ 200	\$ 200
Information Technology	\$ -	\$ -
Animal Control	\$ 18,000	\$ 10,000
Fire	\$ 223,400	\$ 187,800
Police	\$ 158,350	\$ 118,700
Building	\$ 1,105,445	\$ 976,300
By-Law	\$ 10,000	\$ 8,000
Public Works	\$ 51,500	\$ 54,000
Engineering	\$ 137,000	\$ 137,000
Garbage Collection and Disposal	\$ -	\$ -
Cemetery	\$ 99,200	\$ 139,000
Arena	\$ 296,900	\$ 282,150
Parks	\$ 5,000	\$ 5,000
Facilities	\$ 123,000	\$ 156,580
Marina	\$ 76,000	\$ 72,500
Programs & Events	\$ 65,100	\$ 182,000
Planning	\$ 241,250	\$ 221,250
BIA	\$ 155,392	\$ 134,766
<b>Total:</b>	<b>\$ 4,870,337</b>	<b>\$ 4,800,096</b>

<b>Operating Expenditures:</b>	<b>2025 Budget</b>	<b>2026 Budget</b>
Council	\$ 318,961	\$ 345,698
Financial Services	\$ 1,595,693	\$ 1,713,563
CAO Dept	\$ 1,195,711	\$ 1,262,228
Clerks	\$ 589,051	\$ 761,628
Legal	\$ 690,291	\$ 684,750
Information Technology	\$ 865,223	\$ 917,988
Animal Control	\$ 66,550	\$ 66,550
Fire	\$ 2,231,740	\$ 2,369,230
Police	\$ 3,145,187	\$ 3,670,697
Building	\$ 1,375,351	\$ 1,436,789
By-Law	\$ 273,398	\$ 292,054
Public Works	\$ 3,070,110	\$ 3,237,953
Engineering	\$ 1,054,809	\$ 1,131,335
Garbage Collection and Disposal	\$ 1,776,976	\$ 1,880,954
Cemetery	\$ 168,976	\$ 173,199
Arena	\$ 1,303,269	\$ 1,457,212
Parks	\$ 1,266,825	\$ 1,272,592
Facilities	\$ 453,473	\$ 493,026
Marina	\$ 114,099	\$ 143,259
Programs & Events	\$ 729,912	\$ 815,670
Planning	\$ 818,849	\$ 735,291
BIA	\$ 164,698	\$ 135,800
<b>Total:</b>	<b>\$ 23,269,151</b>	<b>\$ 24,997,468</b>
<b>Transfer to (from) Operating Reserves:</b>	<b>\$ (284,797)</b>	<b>\$ (630,523)</b>
<b>Operating Surplus/(Deficit):</b>	<b>\$ (18,114,017)</b>	<b>\$ (19,566,849)</b>

<b>Capital</b>	<b>2025 Budget</b>	<b>2026 Budget</b>
<b>Capital Revenue:</b>	<b>\$ 14,687,137</b>	<b>\$ 28,442,435</b>
<b>Capital Expenditures:</b>		
Council	\$ -	\$ -
Financial Services	\$ -	\$ 300,000
CAO Dept	\$ -	\$ -
Clerks	\$ -	\$ -
Legal	\$ -	\$ -
Information Technology	\$ 199,000	\$ 130,000
Animal Control	\$ -	\$ -
Fire	\$ 215,000	\$ 1,350,000
Police	\$ -	\$ -
Building	\$ 40,000	\$ -
By-Law	\$ -	\$ -
Public Works	\$ 980,000	\$ 1,455,000
Engineering	\$ 8,948,500	\$ 23,147,000
Garbage Collection and Disposal	\$ -	\$ -
Cemetery	\$ -	\$ -
Arena	\$ -	\$ 80,000
Parks	\$ 253,000	\$ 1,565,000
Facilities	\$ 3,760,000	\$ 355,000
Marina	\$ 45,000	\$ -
Programs & Events	\$ -	\$ -
Planning	\$ -	\$ -
BIA	\$ -	\$ -
<b>Total:</b>	<b>\$ 14,440,500</b>	<b>\$ 28,382,000</b>
<b>Transfer to Capital Reserves</b>	<b>\$ 6,130,000</b>	<b>\$ 6,804,000</b>
<b>Repayment of Long-Term Debt</b>	<b>\$ 1,852,078</b>	<b>\$ 1,290,424</b>
<b>Capital Surplus/(Deficit)</b>	<b>\$ (7,735,441)</b>	<b>\$ (8,033,989)</b>
<b>Net Surplus/(Deficit)</b>	<b>\$ -</b>	<b>\$ -</b>

**2026 Assessment Totals**  
**(including Payment In Lieu Assessment)**
**Taxable Assessment**

Realty Tax Class	Realty Tax Qualifier	RTC/RTQ	Current Value Assessment (CVA)
Commercial	Small Scale On-Farm Business	C7	31,200
Commercial	Full	CT	192,987,634
Commercial	Excess Land	CU	1,749,800
Commercial	Vacant Land	CX	1,221,200
Office	Full	DT	955,600
Farm	Full	FT	876,676,934
Parking Lot	Full	GT	71,000
Industrial	Small Scale On-Farm Business	I7	51,000
Industrial	Full	IT	43,712,724
Industrial	Excess Land	IU	761,800
Industrial	Vacant Land	IX	1,861,500
Large Industrial	Full	LT	12,205,200
Large Industrial	Excess Land	LU	53,700
Multi-Residential	Full	MT	23,698,900
New Multi-Residential	Full	NT	1,334,900
Pipeline	Full	PT	25,671,000
Residential	Farmland 1	R1	101,000
Residential	Full	RT	2,359,656,308
Shopping Centre	Full	ST	9,325,300
Shopping Centre	Excess Land	SU	333,900
Managed Forest	Full	TT	929,500
Aggregate Extraction	Full	VT	1,567,000
		Total:	3,554,957,100

**Payment In Lieu Assessment**

Realty Tax Class	Realty Tax Qualifier	RTC/RTQ	Current Value Assessment (CVA)
Commercial	Full	CF	11,776,100
Commercial	General	CG	1,618,000
Commercial	Full, Shared PIL	CH	144,100
Farm	Full, Taxable Tenant of Province	FP	0
Industrial	Full, Shared PIL	IH	366,500
Industrial	Vacant Land, Shared PIL	IJ	57,900
Industrial	Excess Land, Shared PIL	IK	0
Residential	General	RG	24,300
Residential	Full, Shared PIL	RH	0
Residential	Full, Taxable Tenant of Province	RP	23,000
		Total:	14,009,900

**Exempt Assessment**

Realty Tax Class	Realty Tax Qualifier	RTC/RTQ	Current Value Assessment (CVA)
Exempt	Exempt	E	98,899,900
		Total:	98,899,900
		Total:	3,667,866,900

**2026 Tax Rates**

<b>Tax Property Class</b>	<b>Class</b>	<b>Municipal</b>	<b>County</b>	<b>Education</b>	<b>Total</b>
Residential	RT	0.00905796	0.00571906	0.00153000	0.01630703
Farmland	FT	0.00226449	0.00142977	0.00038250	0.00407676
Farmland Awaiting Development Phase 1	R1	0.00226449	0.00142977	0.00038250	0.00407676
Commercial Occupied	CT	0.00980111	0.00618828	0.00880000	0.02478939
Office Building	DT	0.00980111	0.00618828	0.00880000	0.02478939
Commercial Excess Land	CU	0.00980111	0.00618828	0.00880000	0.02478939
Commercial Vacant Land	CX	0.00527626	0.00333135	0.00633473	0.01494235
Commercial Small Scale On-Farm Business	C7	0.00980111	0.00618828	0.00220000	0.01818939
Parking Lot	GT	0.00527626	0.00333135	0.00633473	0.01494235
Multi-Residential	MT	0.00996376	0.00629097	0.00153000	0.01778473
New Multi-Residential	NT	0.00996376	0.00629097	0.00153000	0.01778473
Pipelines	PT	0.01180252	0.00745194	0.00880000	0.02805446
Industrial Occupied	IT	0.01759509	0.01110928	0.00880000	0.03750437
Industrial Excess Land	IU	0.01759509	0.01110928	0.00880000	0.03750437
Industrial Vacant Land	IX	0.01759509	0.01110928	0.00880000	0.03750437
Industrial Small Scale On-Farm Business	I7	0.01759509	0.01110928	0.00220000	0.03090437
Large Industrial Occupied	LT	0.02433059	0.01536198	0.00880000	0.04849257
Large Industrial Excess Land	LU	0.02433059	0.01536198	0.00880000	0.04849257
Managed Forests	TT	0.00226449	0.00142977	0.00038250	0.00407676
Shopping Centres	ST	0.00980111	0.00618828	0.00880000	0.02478939
Shopping Centres Excess Land	SU	0.00980111	0.00618828	0.00880000	0.02478939
Aggregate Extraction	VT	0.01431724	0.00903970	0.00511000	0.02846694

**The Corporation of the Town of Kingsville  
By-law 27-2026**

---

**Being a By-law to provide for the removal of one culvert and the installation of three new culverts over the Ash Cameron Drain, in the Town of Kingsville, in the County of Essex.**

**Whereas** the Council of the Town of Kingsville, in the County of Essex, has procured a report under Section 78 of the *Drainage Act*;

**And whereas** the report has been authored by David Moores, C.E.T., R. Dobbin Engineering Inc., dated March 12, 2026, and the attached report forms part of this By-law;

**And whereas** \$130,019.00 is the amount to be contributed by the owners in the schedule attached for the drainage works;

**And whereas** \$541.00 is the amount to be contributed by the Town of Kingsville in the schedule attached for the drainage works;

**And whereas** Council is of the opinion that the report of the area is desirable;

**Now therefore The Council of the Corporation of the Town of Kingsville, pursuant to the *Drainage Act*, enacts as follows:**

1. **That** the attached report is adopted and the drainage works is authorized and shall be completed as specified in the report.
2. **That** the cost for this report is to be assessed to the owners as described in the attached schedule of assessment.
3. **That** this By-law comes into force and takes effect on the day of the final passing thereof and may be cited as the "Culverts over the Ash Cameron Drain" By-Law.

**Read a first and second time and provisionally adopted this 20<sup>th</sup> day of April, 2026.**

\_\_\_\_\_  
Mayor, Dennis Rogers

\_\_\_\_\_  
Clerk, Angela Toole

**Read a third time and finally passed this \_\_ day of \_\_\_\_\_, 2026.**

\_\_\_\_\_  
Mayor, Dennis Rogers

\_\_\_\_\_  
Clerk, Angela Toole

The Corporation of the Town of Kingsville

By-law 28-2026

Being a By-law to provide for improvements to the Ferry Drain, in the Town of Kingsville, in the County of Essex.

Whereas the Council of the Town of Kingsville, in the County of Essex, has procured a report under Section 78 of the Drainage Act;

And whereas the report has been authored by David Moores, C.E.T., R. Dobbin Engineering Inc., dated March 12, 2026, and the attached report forms part of this By-law;

And whereas \$57,444.00 is the amount to be contributed by the owners in the schedule attached for the drainage works;

And whereas \$1,056.00 is the amount to be contributed by the Town of Kingsville in the schedule attached for the drainage works;

And whereas Council is of the opinion that the report of the area is desirable;

Now therefore The Council of the Corporation of the Town of Kingsville, pursuant to the Drainage Act, enacts as follows:

- 1. That the attached report is adopted and the drainage works is authorized and shall be completed as specified in the report.
2. That the cost for this report is to be assessed to the owners as described in the attached schedule of assessment.
3. That this By-law comes into force and takes effect on the day of the final passing thereof and may be cited as the "Crossings over the Ferry Drain" By-Law.

Read a first and second time and provisionally adopted this 20th day of April, 2026.

Mayor, Dennis Rogers

Clerk, Angela Toole

Read a third time and finally passed this \_\_\_ day of \_\_\_\_\_, 2026.

Mayor, Dennis Rogers

Clerk, Angela Toole

# The Corporation of the Town of Kingsville

## By-law 29-2026

---

**Being a By-law to provide for the establishment of rates for the levy and collection of property taxes in the Town of Kingsville for the year 2026 pursuant to the provisions of the Municipal Act.**

**Whereas** the Council of the Corporation of the Town of Kingsville has reviewed its estimates for the year 2026;

**And whereas** Section 290 (1) of the *Municipal Act, 2001*, S.O. 2001 c. 25, as amended, provides that the Council of a local municipality shall, in each year, prepare and adopt a budget including the estimates of all sums required during the year for the purposes of the municipality;

**And whereas** the Council of the Corporation of the Town of Kingsville has approved the 2026 Town of Kingsville estimates in accordance with Schedule "A" attached hereto;

**And whereas** pursuant to the Corporation of the County of Essex By-law 2026-05, the Corporation of the County of Essex passed a by-law to adopt estimates of all sums required during the year 2026 for the Corporation of the County of Essex and to establish tax rates for the same against the local municipalities;

**And whereas** Section 312 (2) of the *Municipal Act, 2001*, S.O. 2001, c. 25, as amended, provides that the Council of a local municipality shall, after the adoption of estimates for the year, pass a by-law to levy a separate tax rate, as specified in the by-law, on the assessment in each property class in the municipality ratable for local municipal purposes;

**And whereas** Section 312 (6) of the said Act requires tax rates to be established in the same proportion to tax ratios;

**And whereas** The Corporation of the County of Essex passed By-law 2026-05, being a by-law to establish tax ratios for 2026 for the Corporation of the County of Essex and the lower-tier municipalities within the boundaries of the County of Essex, pursuant to Section 308 of the *Municipal Act, 2001*, S.O. 2001, c. 25 as amended;

**And whereas** Sections 315 and 322 of the *Municipal Act, 2001*, S.O. 2001, c.25, as amended, provide for the apportionment of payments in lieu of taxes and taxation of certain railway and power utility lands.

**Now therefore The Council of the Corporation of the Town of Kingsville enacts as follows:**

1. That the 2026 assessment per property class as detailed in Schedule "B" attached hereto and forming part of this by-law, be adopted for purposes of calculating the tax rates for municipal purposes and for determining the levy for the Town of Kingsville.
2. That the amount to be raised by tax rates for the Town of Kingsville purposes in the amount of \$27,210,839, as set out in Schedule "A" attached hereto and forming part of this By-law, be adopted.
3. That the tax rates as listed in Schedule "C" attached to this by-law be applied to the corresponding taxable assessments listed in Schedule "B" to raise sums of \$27,210,839 for general Town purposes; \$17,180,579 for the County of Essex; and \$6,672,256 for education purposes.
4. That the levies listed in clause (3) of this by-law shall be reduced by the amount of the interim levy for 2026.

5. That the 2026 final tax demand be levied in two (2) installments, which will be due and payable on **August 31, 2026** and **November 30, 2026**.
6. That amounts to be collected for local improvements, tile drains, municipal drains, water mains, sewers and miscellaneous charges shall be collected in accordance with their respective authorizing by-laws and are deemed to be imposed and due on the installment due dates listed in clause (5) of this by-law.
7. That the Treasurer and/or Tax Collector, no later than twenty-one (21) days prior to the day the first installment is due, may mail or cause to be mailed to the address of the residence or place of business of each person taxed as aforesaid, a notice specifying the amount of taxes payable by such person/corporation.
8. That pursuant to Section 345 (2) of the *Municipal Act, 2001*, S.O. 2001, C.25, as amended, 1 ¼ per cent of the amount of taxes due and unpaid shall be imposed as a penalty for the non-payment of taxes on the first day of default.
9. That pursuant to Section 345 (3) of the *Municipal Act, 2001*, S.O. 2001, c. 25, as amended, 1 ¼ per cent shall be imposed on outstanding taxes on the first day of the calendar month after payment default and each calendar month thereafter. No discount shall be allowed for pre-payment.
10. That failure to receive a tax notice does not exempt the property owner from penalty and late payment charges as outlined in clauses (8) and (9) of this by-law.
11. Council reserves the right to waive or reduce the penalty and interest calculations outlined in clauses (8) and (9), for specified periods of time, through an approved motion of Council. Any such waivers or reductions shall be applied consistently to all property classes.
12. That taxes shall be payable to The Corporation of the Town of Kingsville at 2021 Division Road North, Kingsville, ON or paid at any financial institution which is authorized to accept payment under the Canadian Payments Association Regulations.
13. That the Treasurer and/or Tax Collector shall hereby be authorized to administer a pre-authorized payment plan for the Town of Kingsville and accept four (4) quarterly due dates or twelve (12) monthly payments on account of taxes due.
14. This By-law shall remain in force from year to year until it is repealed, and any By-law repealing this By-law shall be effective only at the end of any year.
15. In the event of conflict between the provisions of this By-law and any other By-law, the provisions of this By-law shall prevail.
16. This By-law shall come into force and take effect on the day of the final passing thereof.

**Read a first, second, and third time and finally passed this 20<sup>th</sup> day of April, 2026.**

---

Mayor, Dennis Rogers

---

Clerk, Angela Toole

# The Corporation of the Town of Kingsville

## By-law 30-2026

---

### Being a By-law to authorize the establishment of a Joint Election Compliance Audit Committee

**Whereas** Sections 8 and 9 of the *Municipal Act, 2001* S.O. 2001 c. 25, as amended, (the “Act”) provides that a municipality has the capacity, rights, powers and privileges of a natural person for the purpose of exercising the authority conferred upon a municipality to govern its affairs as it considers appropriate;

**And whereas** Section 88.37(1) of the Municipal Elections Act, 1996, as amended (the Act), provides that a Council or local board shall, before October 1 of an election year, establish a compliance audit committee for the purposes of the Act;

**And whereas** Section 88.37(6) of the Municipal Elections Act, 1996, as amended, states that the Clerk of the municipality or the secretary of the local board, as the case may be, shall establish administrative practices and procedures for the committee and shall carry out any other duties required under this Act to implement the committee's decisions;

**And whereas** the Town of Amherstburg, Town of Essex, Town of Kingsville, Municipality of Lakeshore, Town of Lasalle, and Town of Tecumseh deem it expedient to establish a Joint Election Compliance Audit Committee for the purposes of the Act.

### Now therefore The Council of the Corporation of the Town of Kingsville enacts as follows:

1. **That** a Committee to be known as the Joint Election Compliance Audit Committee, is hereby established to deal with the matters provided for in Sections 88.33, 88.34, 88.35, and 88.36 of the Act for the 2026-2030 term of Council;
2. **That** the business of the Joint Election Compliance Audit Committee be conducted in accordance with the Terms of Reference set out in Schedule “A” attached hereto and forming a part of this By-law; and
3. **That** this By-law comes into force and takes effect on the day of the final passing thereof.

**Read a first, second and third time and finally passed this 20<sup>th</sup> day of April, 2026.**

---

Mayor, Dennis Rogers

---

Clerk, Angela Toole

**The Corporation of the Town of Kingsville**  
**By-law 31-2026**

---

**Being a By-law to confirm the proceedings of the  
Council of the Corporation of the Town of Kingsville at its  
April 20, 2026, Regular Meeting of Council**

**Whereas** sections 8 and 9 of the *Municipal Act, 2001* S.O. 2001 c. 25, as amended, (the "Act") provides that a municipality has the capacity, rights, powers and privileges of a natural person for the purpose of exercising the authority conferred upon a municipality to govern its affairs as it considers appropriate;

**And whereas** section 5(3) of the Act provides that such power shall be exercised by by-law, unless the municipality is specifically authorized to do so otherwise;

**And whereas** it is deemed expedient that the proceedings of the Council of The Corporation of the Town of Kingsville (the "Town") be confirmed and adopted by by-law;

**Now therefore the Council of The Corporation of the Town of Kingsville enacts as follows:**

1. The actions of the Council at its April 20, 2026, Regular Meeting in respect of each report, motion, resolution or other action taken or direction given by the Council at its meeting, is hereby adopted, ratified and confirmed, as if each resolution or other action was adopted, ratified and confirmed by its separate by-law.
2. The Chief Administrative Officer and/or the appropriate officers of the Town are hereby authorized and directed to do all things necessary to give effect to the actions set out in paragraph 1, or obtain approvals, where required, and, except where otherwise provided, the Mayor and the Clerk are hereby directed to execute all documents necessary and to affix the corporate seal to all such documents.
3. This By-law comes into force and takes effect on the day of the final passing thereof.

**Read a first, second, and third time and finally passed this 20<sup>th</sup> day of April 2026.**

---

Mayor, Dennis Rogers

---

Clerk, Angela Toole